

PLEASE CHECK WWW.MOLEX.COM FOR LATEST PART INFORMATION

Part Number: [0039306128](#)
Status: **Active**
Overview: [minifit_jr](#)
Description: 4.20mm (.165") Pitch Mini-Fit Jr.™ Header, Dual Row, Vertical, with Snap-in Plastic Peg PCB Lock, 12 Circuits, PA Polyamide Nylon 6/6, UL 94V-0, Tin (Sn) Over Nickel (Ni) Plating, with Drain Holes
Replacement Part Number: 0.165

Documents:

[3D Model](#) [Product Specification PS-5556-001 \(PDF\)](#)
[Drawing \(PDF\)](#) [RoHS Certificate of Compliance \(PDF\)](#)

Agency Certification

CSA	LR19980
TUV	R72081037
UL	E29179

General

Product Family	PCB Headers
Series	5566
Application	Wire-to-Board
Comments	Current = 13A max. per circuit when header is mated to a receptacle loaded with 45750 Mini-Fit Plus HCS™ Crimp Terminal Crimped to to 16 AWG wire. . See Molex product specification PS-45750-001 for additional current de-rating information.. High Temperature, Square Pin, Solder Type
Overview	minifit_jr
Product Name	Mini-Fit Jr.™
Replacement Part Number	0.165

Physical

Breakaway	No
Circuits (Loaded)	12
Circuits (maximum)	12
Color - Resin	Natural
Durability (mating cycles max)	30
First Mate / Last Break	No
Flammability	94V-0
Glow-Wire Compliant	No
Guide to Mating Part	No
Keying to Mating Part	None
Lock to Mating Part	Yes
Material - Metal	Brass
Material - Plating Mating	Tin
Material - Plating Termination	Tin
Material - Resin	Nylon
Number of Rows	2
Orientation	Vertical
PC Tail Length (in)	0.138 In
PC Tail Length (mm)	3.50 mm
PCB Locator	Yes
PCB Retention	Yes
PCB Thickness Recommended (in)	0.062 In
PCB Thickness Recommended (mm)	1.60 mm

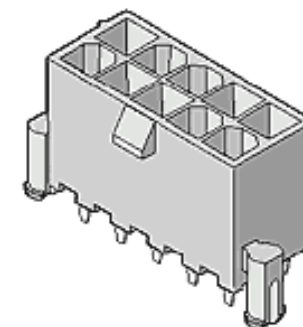

image - Reference only

Series

EU RoHS

ELV and RoHS Compliant
REACH SVHC Not Reviewed
Halogen-Free Status Not Reviewed

China RoHS



Need more information on product environmental compliance?

Email productcompliance@molex.com
 For a multiple part number RoHS Certificate of Compliance, [click here](#)

Please visit the [Contact Us](#) section for any non-product compliance questions.

Search Parts in this Series

[5566Series](#)

Mates With

[5557](#) Mini-Fit Jr.™ Receptacle Housing

Packaging Type	Tray
Pitch - Mating Interface (in)	0.165 In
Pitch - Mating Interface (mm)	4.20 mm
Pitch - Term. Interface (in)	0.165 In
Pitch - Term. Interface (mm)	4.20 mm
Plating min: Mating (µin)	100
Plating min: Mating (µm)	2.50
Plating min: Termination (µin)	100
Plating min: Termination (µm)	2.50
Polarized to Mating Part	Yes
Polarized to PCB	Yes
Shrouded	Fully
Stackable	No
Surface Mount Compatible (SMC)	No
Temperature Range - Operating	-40°C to +105°C
Termination Interface: Style	Through Hole

Electrical

Current - Maximum per Contact	13A
Voltage - Maximum	600V

Material Info

Old Part Number	5566-12B2S-210
-----------------	----------------

Reference - Drawing Numbers

Packaging Specification	PK-5566-001
Product Specification	PS-5556-001
Sales Drawing	SDA-5566-N*2*-*
Test Summary	TS-5556-002

This document was generated on 05/21/2010

PLEASE CHECK WWW.MOLEX.COM FOR LATEST PART INFORMATION



NOTES:

- 1) HOUSING MATERIAL:
 - "BLANK" - NYLON 6/6, U.L. 94V-2, COLOR: NATURAL.
 - 210 - NYLON 6/6, U.L. 94V-0, COLOR: NATURAL.
 - BL - NYLON 6/6, U.L. 94V-2, COLOR: DYED BLACK.
- 2) TERMINAL MATERIAL: BRASS ALLOY 260
- 3) PART MATES WITH MINI-FIT JR. RECEPTACLE #5557.
- 4) PACKAGING: SEE CHARTS
- 5) MOUNTING OPTIONS:
 - "BLANK" - NO MOUNTING (SEE SD-5566-NA AND -NB SERIES DWGS.)
 - 2 - PEG MOUNT
- 6) TERMINAL PLATING:
 - "BLANK" - .000035/(.00090) MIN. TIN OVER .000020/(.00050) MIN. COPPER.
 - *GS - .000030/(.00076) MIN. SELECT GOLD .000100/(.00254) MIN. SELECT MATTE TIN OVER .000050/(.00127) MIN. NICKEL OVERALL.
 - *GS2 - .000015/(.00038) MIN. SELECT GOLD AND .000100/(.00254) MIN. SELECT MATTE TIN OVER .000050/(.00127) MIN. NICKEL OVERALL.
 - S - .000100/(.00254) MIN. TIN OVER .000050/(.00127) MIN. NICKEL.
- *THE PRIMARY SHIPPING CARTON WILL BE LABELED "COMPLIANT TO RoHS DIRECTIVE 2002/95/EC AND ELV ANNEX II OF DIRECTIVE 2000/53/EC."
- *CARTONS WITHOUT THIS LABEL MAY CONTAIN PRODUCT WITH TIN-LEAD PLATING.
- 7) PRODUCT SPECIFICATION AND PROCESSING PARAMETERS: SEE PS-5566-001
- 8) ANTI-SHINGLING RIB MAY OR MAY NOT APPEAR ON HOUSINGS.
- 9) CONNECTORS ARE NOT TO BE MATED OR UNMATED WHILE CIRCUITS ARE LIVE.
- 10) PARTS ARE NOT DESIGNED FOR CURRENT SHARING.



RECOMMENDED HOLE LAYOUT FOR .070/(1.78) MAX. THICK P. C. BOARD

VIEWED FROM COMPONENT SIDE

CIRCUIT SIZE	DIM. "A"	DIM. "B"	DIM. "C"
2	—	.21 (5.4)	.370 (9.40)
4	.17 (4.2)	.38 (9.6)	.535 (13.60)
6	.33 (8.4)	.54 (13.8)	.701 (17.80)
8	.50 (12.6)	.71 (18.0)	.866 (22.00)
10	.66 (16.8)	.87 (22.2)	1.031 (26.20)
12	.83 (21.0)	1.04 (26.4)	1.197 (30.40)
14	.99 (25.2)	1.20 (30.6)	1.362 (34.60)
16	1.16 (29.4)	1.37 (34.8)	1.528 (38.80)
18	1.32 (33.6)	1.54 (39.0)	1.693 (43.00)
20	1.49 (37.8)	1.70 (43.2)	1.858 (47.20)
22	1.65 (42.0)	1.87 (47.4)	2.024 (51.40)
24	1.82 (46.2)	2.03 (51.6)	2.189 (55.60)

LEGEND:



4	R2
3	R2
2	R2
1	R2
SHT. REV.	

REVISED NOTES 8 EC NO: UCP2009-1336 DRAWN: JLOSTEMEIER 2008/11/24 CHKD: JBEL 2008/11/24 APPR: FSMITH 2008/11/24	QUALITY SYMBOLS ▽=0 ▽=0	GENERAL TOLERANCES (UNLESS SPECIFIED) <table border="1"> <thead> <tr> <th></th> <th>mm</th> <th>INCH</th> </tr> </thead> <tbody> <tr> <td>4 PLACES ±</td> <td>---</td> <td>---</td> </tr> <tr> <td>3 PLACES ±</td> <td>---</td> <td>±.015</td> </tr> <tr> <td>2 PLACES ±</td> <td>0.38</td> <td>±.015</td> </tr> <tr> <td>1 PLACE ±</td> <td>0.38</td> <td>±---</td> </tr> </tbody> </table>		mm	INCH	4 PLACES ±	---	---	3 PLACES ±	---	±.015	2 PLACES ±	0.38	±.015	1 PLACE ±	0.38	±---	DIMENSION STYLE IN/MM	SCALE 1:1	DESIGN UNITS METRIC	THIRD ANGLE PROJECTION
		mm	INCH																		
	4 PLACES ±	---	---																		
	3 PLACES ±	---	±.015																		
2 PLACES ±	0.38	±.015																			
1 PLACE ±	0.38	±---																			
MATERIAL NO. SEE SHTS 2-4	DRAWN BY RJF	DATE 8/19/87	TITLE MINI-FIT JR. VERTICAL HEADER ASSEMBLIES WITH MOUNTING PEGS	MOLEX MOLEX INCORPORATED	SHEET NO. 1 OF 4																
DRAFT WHERE APPLICABLE MUST REMAIN WITHIN DIMENSIONS	APPROVED BY RAS	DATE 8/19/87	MATERIAL NO. SDA-5566-N*2*-*																		
SIZE C	THIS DRAWING CONTAINS INFORMATION THAT IS PROPRIETARY TO MOLEX INCORPORATED AND SHOULD NOT BE USED WITHOUT WRITTEN PERMISSION																				

	13	12	11	10	9	8	7	6	5	4	3	2	1			
J	PLATING:		100 M.I. TIN		PLATING:		100 M.I. TIN		PLATING:		15 M.I. SELECT GOLD		PLATING:		15 M.I. SELECT GOLD	
	DRAIN HOLES:		WITHOUT DRAIN HOLES		DRAIN HOLES:		WITHOUT DRAIN HOLES		DRAIN HOLES:		WITHOUT DRAIN HOLES		DRAIN HOLES:		WITHOUT DRAIN HOLES	
	MTG. OPTION:		WITH PEGS		MTG. OPTION:		WITH PEGS		MTG. OPTION:		WITH PEGS		MTG. OPTION:		WITH PEGS	
	HOUSING MAT'L:		NYLON 6/6 94V-2 NATURAL		HOUSING MAT'L:		NYLON 6/6 94V-0 NATURAL		HOUSING MAT'L:		NYLON 6/6 94V-2 NATURAL		HOUSING MAT'L:		NYLON 6/6 94V-0 NATURAL	
	PACKAGING:		TRAY		PACKAGING:		TRAY		PACKAGING:		TRAY		PACKAGING:		TRAY	
I	PART NO.	ENG NO.	CKTS		PART NO.	ENG NO.	CKTS		PART NO.	ENG NO.	CKTS		PART NO.	ENG NO.	CKTS	
	39-30-6025	5566 -02A2S	2		39-30-6026	5566 -02A2S-210	2		39-30-0026	5566 -02A2GS2	2		39-30-0027	5566 -02A2GS2-210	2	
	39-30-6045	5566 -04A2S	4		39-30-6046	5566 -04A2S-210	4		39-30-0046	5566 -04A2GS2	4		39-30-0047	5566 -04A2GS2-210	4	
	39-30-6065	5566 -06A2S	6		39-30-6066	5566 -06A2S-210	6		39-30-0066	5566 -06A2GS2	6		39-30-0067	5566 -06A2GS2-210	6	
	39-30-6085	5566 -08A2S	8		39-30-6086	5566 -08A2S-210	8		39-30-0086	5566 -08A2GS2	8		39-30-0087	5566 -08A2GS2-210	8	
	39-30-6105	5566 -10A2S	10		39-30-6106	5566 -10A2S-210	10		39-30-0106	5566 -10A2GS2	10		39-30-0107	5566 -10A2GS2-210	10	
	39-30-6125	5566 -12A2S	12		39-30-6126	5566 -12A2S-210	12		39-30-0126	5566 -12A2GS2	12		39-30-0127	5566 -12A2GS2-210	12	
	39-30-6145	5566 -14A2S	14		39-30-6146	5566 -14A2S-210	14		39-30-0146	5566 -14A2GS2	14		39-30-0147	5566 -14A2GS2-210	14	
	39-30-6165	5566 -16A2S	16		39-30-6166	5566 -16A2S-210	16		39-30-0166	5566 -16A2GS2	16		39-30-0167	5566 -16A2GS2-210	16	
	39-30-6185	5566 -18A2S	18		39-30-6186	5566 -18A2S-210	18		39-30-0186	5566 -18A2GS2	18		39-30-0187	5566 -18A2GS2-210	18	
	39-30-6205	5566 -20A2S	20		39-30-6206	5566 -20A2S-210	20		39-30-0206	5566 -20A2GS2	20		39-30-0207	5566 -20A2GS2-210	20	
	39-30-6225	5566 -22A2S	22		39-30-6226	5566 -22A2S-210	22		39-30-0226	5566 -22A2GS2	22		39-30-0227	5566 -22A2GS2-210	22	
	39-30-6245	5566 -24A2S	24		39-30-6246	5566 -24A2S-210	24		39-30-0246	5566 -24A2GS2	24		39-30-0247	5566 -24A2GS2-210	24	
		-				-				-				-		
		-				-				-				-		

G	PLATING:		100 M.I. TIN		PLATING:		100 M.I. TIN		PLATING:		15 M.I. SELECT GOLD		PLATING:		15 M.I. SELECT GOLD	
	DRAIN HOLES:		WITH DRAIN HOLES		DRAIN HOLES:		WITH DRAIN HOLES		DRAIN HOLES:		WITH DRAIN HOLES		DRAIN HOLES:		WITH DRAIN HOLES	
	MTG. OPTION:		WITH PEGS		MTG. OPTION:		WITH PEGS		MTG. OPTION:		WITH PEGS		MTG. OPTION:		WITH PEGS	
	HOUSING MAT'L:		NYLON 6/6 94V-2 NATURAL		HOUSING MAT'L:		NYLON 6/6 94V-0 NATURAL		HOUSING MAT'L:		NYLON 6/6 94V-2 NATURAL		HOUSING MAT'L:		NYLON 6/6 94V-0 NATURAL	
	PACKAGING:		TRAY		PACKAGING:		TRAY		PACKAGING:		TRAY		PACKAGING:		TRAY	
F	PART NO.	ENG NO.	CKTS		PART NO.	ENG NO.	CKTS		PART NO.	ENG NO.	CKTS		PART NO.	ENG NO.	CKTS	
	39-30-6027	5566 -02B2S	2		39-30-6028	5566 -02B2S-210	2		39-30-0028	5566 -02B2GS2	2		39-30-0029	5566 -02B2GS2-210	2	
	39-30-6047	5566 -04B2S	4		39-30-6048	5566 -04B2S-210	4		39-30-0048	5566 -04B2GS2	4		39-30-0049	5566 -04B2GS2-210	4	
	39-30-6067	5566 -06B2S	6		39-30-6068	5566 -06B2S-210	6		39-30-0068	5566 -06B2GS2	6		39-30-0069	5566 -06B2GS2-210	6	
	39-30-6087	5566 -08B2S	8		39-30-6088	5566 -08B2S-210	8		39-30-0088	5566 -08B2GS2	8		39-30-0089	5566 -08B2GS2-210	8	
	39-30-6107	5566 -10B2S	10		39-30-6108	5566 -10B2S-210	10		39-30-0108	5566 -10B2GS2	10		39-30-0109	5566 -10B2GS2-210	10	
	39-30-6127	5566 -12B2S	12		39-30-6128	5566 -12B2S-210	12		39-30-0128	5566 -12B2GS2	12		39-30-0129	5566 -12B2GS2-210	12	
	39-30-6147	5566 -14B2S	14		39-30-6148	5566 -14B2S-210	14		39-30-0148	5566 -14B2GS2	14		39-30-0149	5566 -14B2GS2-210	14	
	39-30-6167	5566 -16B2S	16		39-30-6168	5566 -16B2S-210	16		39-30-0168	5566 -16B2GS2	16		39-30-0169	5566 -16B2GS2-210	16	
	39-30-6187	5566 -18B2S	18		39-30-6188	5566 -18B2S-210	18		39-30-0188	5566 -18B2GS2	18		39-30-0189	5566 -18B2GS2-210	18	
	39-30-6207	5566 -20B2S	20		39-30-6208	5566 -20B2S-210	20		39-30-0208	5566 -20B2GS2	20		39-30-0209	5566 -20B2GS2-210	20	
	39-30-6227	5566 -22B2S	22		39-30-6228	5566 -22B2S-210	22		39-30-0228	5566 -22B2GS2	22		39-30-0229	5566 -22B2GS2-210	22	
	39-30-6247	5566 -24B2S	24		39-30-6248	5566 -24B2S-210	24		39-30-0248	5566 -24B2GS2	24		39-30-0249	5566 -24B2GS2-210	24	
		-				-				-				-		
		-				-				-				-		

C																	C
B																	B
A																	A
REV. PACKAGING		REV. DESCRIPTION		QUALITY SYMBOLS		GENERAL TOLERANCES (UNLESS SPECIFIED)		DIMENSION STYLE		SCALE		DESIGN UNITS		THIRD ANGLE PROJECTION			
EC NO: UCP2009-1336		DRWN:KLOSTEMEIER 2008/11/24		▽=0		mm INCH		IN/MM		1:1		METRIC		⊙ □			
DRAWN:KLOSTEMEIER 2008/11/24		CHKD:JBELL 2008/11/24		▽=0		4 PLACES ± --- ± ---		DRAWN BY DATE		TITLE		MOLEX MOLEX INCORPORATED		SHEET NO.			
APPR:FSMITH 2008/11/24						3 PLACES ± --- ±.015		MAB 2/17/99		MINI-FIT JR VERT. HEADER ASSEMBLIES WITH MOUNTING PEGS				3			
						2 PLACES ± 0.38 ±.015		APPROVED BY DATE		RRE 2/17/99							
						1 PLACE ± 0.38 ± ---		MATERIAL NO.		SEE CHART		SDA-5566-N*2*-*					
						ANGULAR ±1/2°		DOCUMENT NO.									
						DRAFT WHERE APPLICABLE MUST REMAIN WITHIN DIMENSIONS		SIZE		THIS DRAWING CONTAINS INFORMATION THAT IS PROPRIETARY TO MOLEX INCORPORATED AND SHOULD NOT BE USED WITHOUT WRITTEN PERMISSION							