

PLEASE CHECK WWW.MOLEX.COM FOR LATEST PART INFORMATION

Part Number: **0039000216**
Status: **Active**
Overview: [minifit_jr](#)
Description: 4.20mm (.165") Pitch Mini-Fit™ Crimp Terminal, Female, Phosphor Bronze, Tin (Sn), 22-28 AWG, Bag

Documents:

Test Summary (PDF)	Product Specification PS-5556-002 (PDF)
Drawing (PDF)	Product Specification PS-5556-003 (PDF)
Product Specification PS-5556-001 (PDF)	RoHS Certificate of Compliance (PDF)

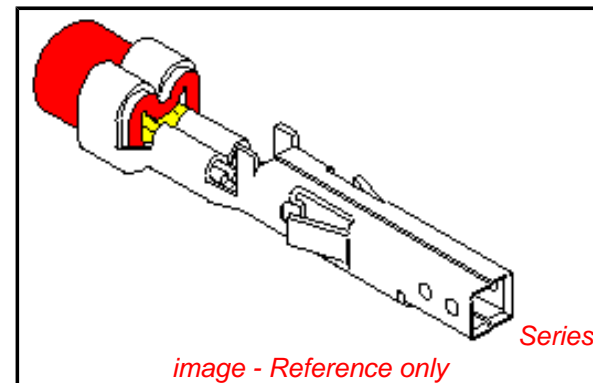

General

Product Family	Crimp Terminals
Series	5556
Crimp Quality Equipment	Yes
Overview	minifit_jr
Product Name	Mini-Fit®

Physical

Durability (mating cycles max)	30
Gender	Female
Material - Metal	Phosphor Bronze
Material - Plating Mating	Tin
Material - Plating Termination	Nickel
Packaging Type	Bag
Plating min: Mating (µin)	100
Plating min: Mating (µm)	2.54
Plating min: Termination (µin)	50
Plating min: Termination (µm)	1.27
Termination Interface: Style	Crimp or Compression
Wire Insulation Diameter	0.90-1.80mm (.035-.071")
Wire Size AWG	22, 24, 26, 28
Wire Size mm²	N/A

Electrical

Current - Maximum per Contact	9A
Voltage - Maximum	600V

Material Info

Old Part Number	5556-PBS2PL
-----------------	-------------

Reference - Drawing Numbers

Packaging Specification	PK-5556-003
Product Specification	PS-5556-001, PS-5556-002, PS-5556-003
Test Summary	TS-5556-002

EU RoHS ELV and RoHS Compliant REACH SVHC Contains SVHC: No Halogen-Free Status Halogen-Free	China RoHS
---	-----------------------

Need more information on product environmental compliance?

Email productcompliance@molex.com
 For a multiple part number RoHS Certificate of Compliance, [click here](#)

Please visit the [Contact Us](#) section for any non-product compliance questions.

Search Parts in this Series
5556Series

Mates With
5558 Male Crimp Terminals. Mini-Fit Jr.™ Header, Dual Row, 5566 , 5569

Use With
5557 Mini-Fit Jr.™ Receptacle Housing, 30067 TPA, 42474 BMI Panel Mount, 5559 Mini-Fit Jr.™ Plug Housing, Dual Row

Application Tooling | FAQ
Tooling specifications and manuals are found by selecting the products below. Crimp Height Specifications are then contained in the Application Tooling Specification document.

Global	
Description	Product #
Hand Crimp Tool for Mini-Fit Jr.™ Crimp Terminals	0638191000

This document was generated on 06/01/2010

PLEASE CHECK WWW.MOLEX.COM FOR LATEST PART INFORMATION

PART NO.	ENG. NO.	MAT'L.	PLATE	WIRE GAGE	QUANTITY PER REEL	DIM. "B"	DIM. "C"	DIM. "D"	DIM. "E"	DIM. "F"	DIM. "G"	
39-00-0207	5556-SP	A	A	18-24 GA.	4,000	.142±.012 (3.60±0.30)	.177±.016 (4.50±0.40)	.035 (0.90)	.075±.012 (1.90±0.30)	.091±.016 (2.40±0.40)	.020 (0.50)	
39-00-0208	5556-SPL			22-28 GA.	6,000	.091±.012 (2.30±0.30)	.091±.016 (2.30±0.40)	.024 (0.60)	.071±.012 (1.80±0.30)	.065±.016 (1.65±0.40)	.016 (0.40)	
39-00-0209	5556-S2P			16 GA.	4,000	.142±.012 (3.60±0.30)	.177±.016 (4.50±0.30)	.035 (0.90)	.091±.012 (2.30±0.30)	.106±.016 (2.70±0.40)	.024 (0.60)	
39-00-0210	5556-S2PL											
39-00-0211	5556-S3P											
39-00-0212	5556-S3PL											
NOT TOOLED	5556-S5P	B	A	28-30 GA.	6,000	.091±.012 (2.30±0.30)	.091±.016 (2.30±0.40)	.024 (.60)	.050±.010 (1.27±0.25)	.044±.010 (1.12±0.25)	.010 (0.25)	
NOT TOOLED	5556-S5PL			18-24 GA.	4,000	.142±.012 (3.60±0.30)	.177±.016 (4.50±0.40)	.035 (0.90)	.075±.012 (1.90±0.30)	.091±.016 (2.40±0.40)	.020 (0.50)	
39-00-0213	5556-PBSP			22-28 GA.	6,000	.091±.012 (2.30±0.30)	.091±.016 (2.30±0.40)	.024 (0.60)	.071±.012 (1.80±0.30)	.065±.016 (1.65±0.40)	.016 (0.40)	
39-00-0214	5556-PBSPL			16 GA.	4,000	.142±.012 (3.60±0.30)	.177±.016 (4.50±0.30)	.035 (0.90)	.091±.012 (2.30±0.30)	.106±.016 (2.70±0.40)	.024 (0.60)	
39-00-0215	5556-PBS2P											
39-00-0216	5556-PBS2PL											
39-00-0217	5556-PBS3P											
39-00-0218	5556-PBS3PL											
NOT TOOLED	5556-PBS5P			28-30 GA.	6,000	.091±.012 (2.30±0.30)	.091±.016 (2.30±0.40)	.024 (.60)	.050±.010 (1.27±0.25)	.044±.010 (1.12±0.25)	.010 (0.25)	
NOT TOOLED	5556-PBS5PL											

LEGEND:

5556 - ** S * P *

BASE NO. _____

MATERIAL _____

BLANK= BRASS

PB= PHOS. BRONZE

S= TIN OVER NICKEL

PLATING & CRIMP SIZE COMB. _____

BLANK THRU 5

CHAIN OR LOOSE _____

BLANK= CHAIN

L= LOOSE

NOTES:

- PART DESIGNED IN METRIC.
- TERMINAL FOR USE WITH 5557, 42474, 43760 AND 30067 SERIES HOUSINGS.
- MATES WITH 5558, 5566 AND 5569 SERIES CONNECTORS.
- REFER TO DWG. NO. CS-5556*/5558* FOR CRIMP SPECIFICATIONS.
- MATERIAL:
 - A= BRASS, CDA 260
 - B= PHOS. BRONZE, CDA 510
- PLATING:
 - A= .000100/(.00254) MIN. BRIGHT TIN OVER .000050/(.00127) MIN. NICKEL.
- PRODUCT SPECIFICATION: PS-5556-001, PS-5556-002, PS-5556-003

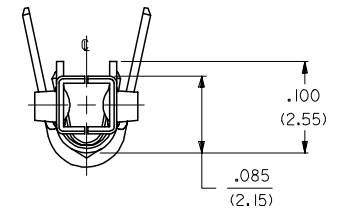
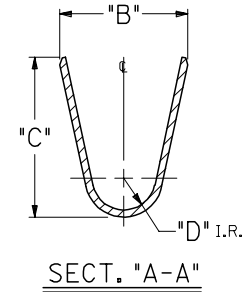
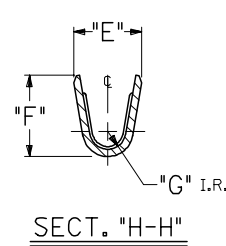
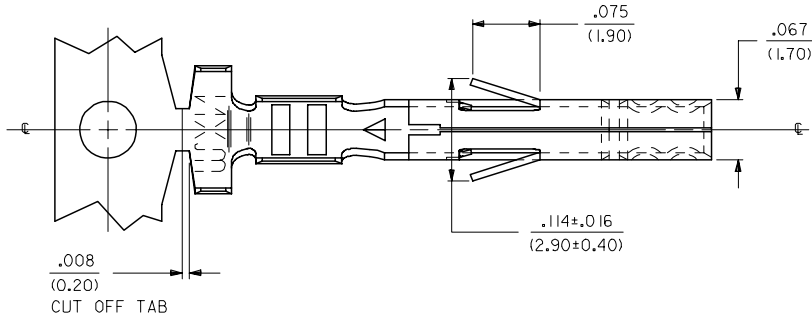

RoHS COMPLIANT

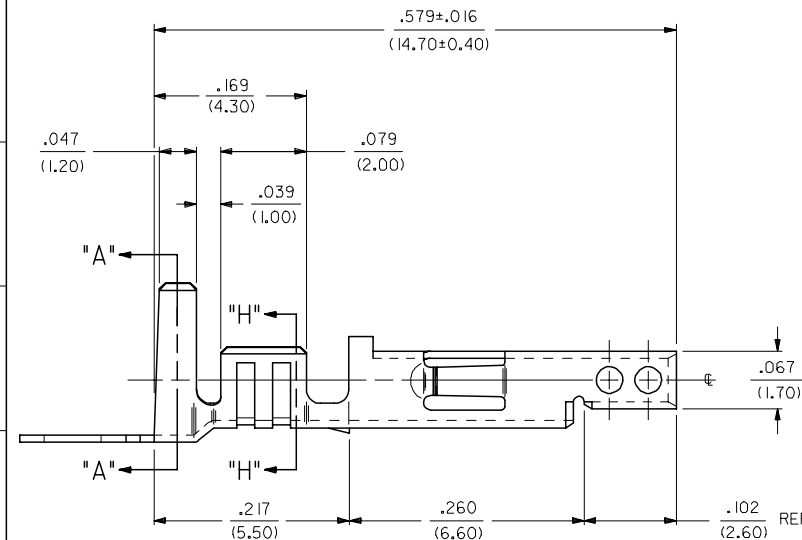

REMOVED 14 GA. FC NO: UCP2005-2552 DRW:NDUNNE 2005/06/01 CHKD:GOLGAR 2005/06/01 APPR: YMARGULL 2005/06/03	QUALITY SYMBOLS	GENERAL TOLERANCES (UNLESS SPECIFIED)	DIMENSION STYLE IN/MM	SCALE 10:1	DESIGN UNITS INCH	THIRD ANGLE PROJECTION														
	DESCRIPTION	<table border="1"> <tr> <th>PLACES</th> <th>mm</th> <th>INCH</th> </tr> <tr> <td>4 PLACES</td> <td>± .10</td> <td>± .004</td> </tr> <tr> <td>3 PLACES</td> <td>± .15</td> <td>± .006</td> </tr> <tr> <td>2 PLACES</td> <td>± .25</td> <td>± .010</td> </tr> <tr> <td>1 PLACE</td> <td>± .36</td> <td>± .014</td> </tr> </table>	PLACES	mm	INCH	4 PLACES	± .10	± .004	3 PLACES	± .15	± .006	2 PLACES	± .25	± .010	1 PLACE	± .36	± .014	DRAWN BY DATE GEP 5/17/1990	TITLE MINI FIT JR TERMINAL FEMALE, CRIMP, TIN/NICKLE	MATERIAL NO. SD-5556-SP*
PLACES	mm	INCH																		
4 PLACES	± .10	± .004																		
3 PLACES	± .15	± .006																		
2 PLACES	± .25	± .010																		
1 PLACE	± .36	± .014																		
REV	DRAFT WHERE APPLICABLE MUST REMAIN WITHIN DIMENSIONS	APPROVED BY DATE RAS 5/17/1990	MATERIAL NO. SD-5556-SP*		SHEET NO. 1 OF 1															
THIS DRAWING CONTAINS INFORMATION THAT IS PROPRIETARY TO MOLEX INCORPORATED AND SHOULD NOT BE USED WITHOUT WRITTEN PERMISSION																				