

**MOTOROLA
SEMICONDUCTOR**
TECHNICAL DATA

Prototype Information

Automotive 12V ignition driver

The MC33191 is for use in 12V ignition systems designed for use in harsh automotive and industrial applications which require the capability of handling high voltage attributed to load and field dump transients. In addition, the device can be used under reverse and double battery conditions.

The MC33191 is available in a 16 pin narrow body DIP plastic and SO package.

- Designed for Automotive Ignition Application
- Continuous System Voltage up to 28.6V
- Continuous Operating Ambient Temperature Range from -30°C to +125°C
- Frequency Range from 1Hz to 400 Hz
- Coil Current Regulation
- Hall Effect and Reluctance Sensor Applications.

MC33191

12V IGNITION DRIVER

SILICON MONOLITHIC
INTEGRATED CIRCUIT



P SUFFIX
PLASTIC PACKAGE
CASE 648-06



DW SUFFIX
PLASTIC PACKAGE
CASE 751G
SO-16L

PIN ASSIGNMENT

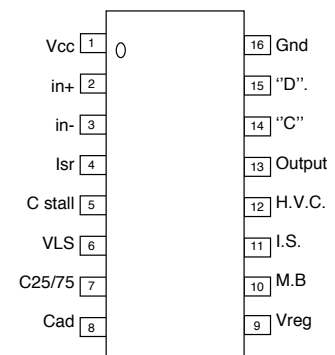

ORDERING INFORMATION

Device	Temperature Range	Package
MC33191P	-30°C to +125°C	DIL16

Simplified Block Diagram

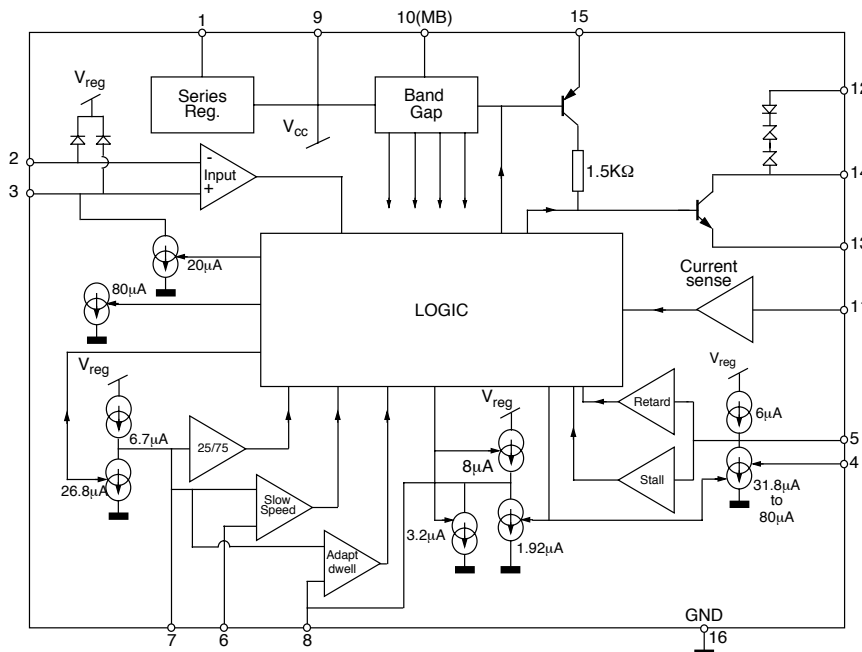

DEVICE PIN OUT IDENTIFICATION

Pin	Function	Pin	Function
1	V _{cc}	9	V _{reg}
2	Input +	10	Master Bias
3	Input -	11	Current Sense
4	Start Retard I Trim	12	High Voltage Clamp
5	Stall Capacitor	13	Output
6	V Low Speed	14	" C "
7	25/75 Capacitor	15	" D "
8	Adaptive Dwell Cap.	16	Master bias

ELECTRICAL REQUIREMENTS The IC performs to the limits of the table between temperature range of - 30°C to +125°C and it operates between the temperature range of - 40°C to +150°C

Symbol	Description	Min	Max	Unit
ICC	I.C.Drain Current	3	5	mA
V _{reg}	Regulator output voltage	6,5	7,1	V
ICCH	I.C. Drain Current High Voltage		10	mA
V _{in} (+) P	(+) Input, Positive Clamp	7	8	V
V _{in} (+) N	(+) Input, Negative Clamp	1	2	V
V _{in} (-) P	(-) Input, Positive Clamp	7	8	V
V _{in} (-) N	(-) Input, Negative Clamp	1	2	V
V _{in} TH	Input Threshold	-25	+25	mA
V _{in} Hys. RM	Run Mode Hysteresis	280	372	mV
V _{in} Hys. SS	Slow Speed Hysteresis	54	88	mV
I75	25/75 Current Up	6.2	7.68	μA
I75 / I25	I75 / I25 Current ratio	0.317	0.365	
I75 / I ADU	I75 / IADU Current ratio	0.794	0.878	
I ADU / IADD	IADU / IADD Current ratio	1.49	1.7	
I ADU / IADR	I ADU / I ADR Current ratio	2.35	2.66	
VEDR	Reduced Excess Dwell Trip Voltage	15.5	19	V
I75 / ISU	I75 / I SU Current Ratio	1.05	1.27	
I SD / I SU	I SD/ I SU Current ratio	3.9	4.95	
VHVC	Collector Clamp Voltage	14.4	16.7	V
VCS	Current Sense Voltage	133	185	mV
VOS	Output Saturation Voltage		985	mV
IOLK	Output Leakage Current		25	μA
VOSD	Overvoltage Shutdown Voltage	27	30	V
VSSS	Slow Speed Stall	2.4	3.1	V

Figure 1. Test Schematic

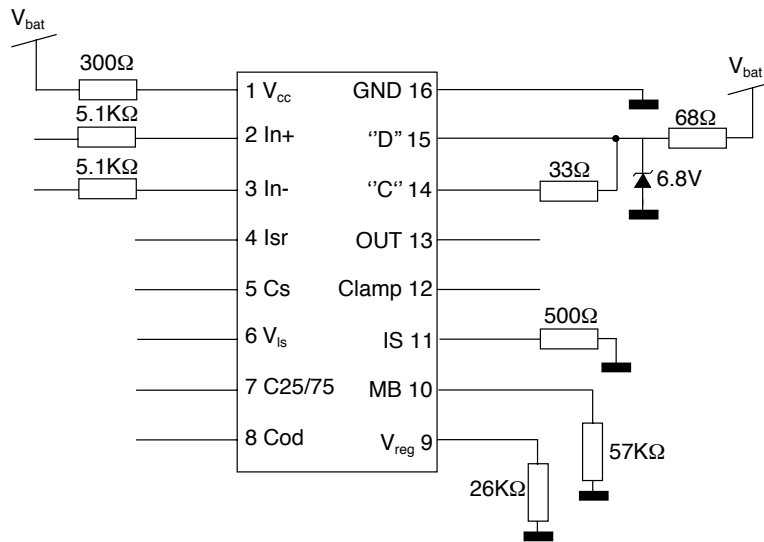

Figure 2. Application Circuit (Reluctance Sensor Input)

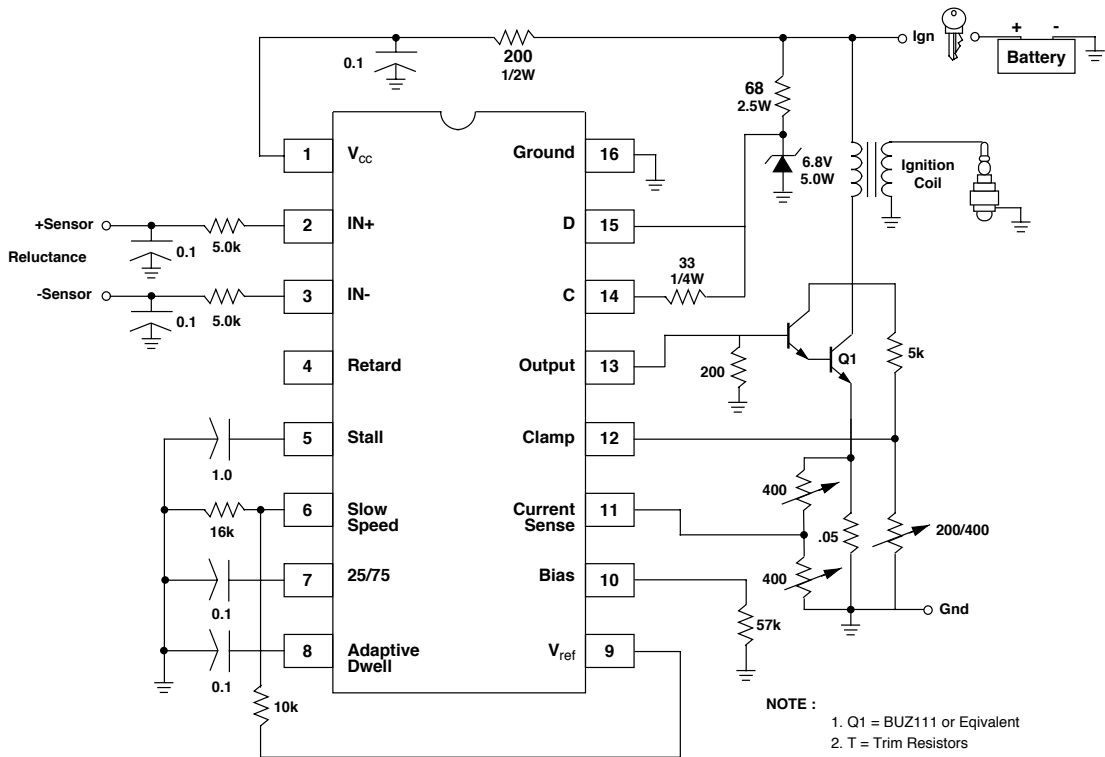
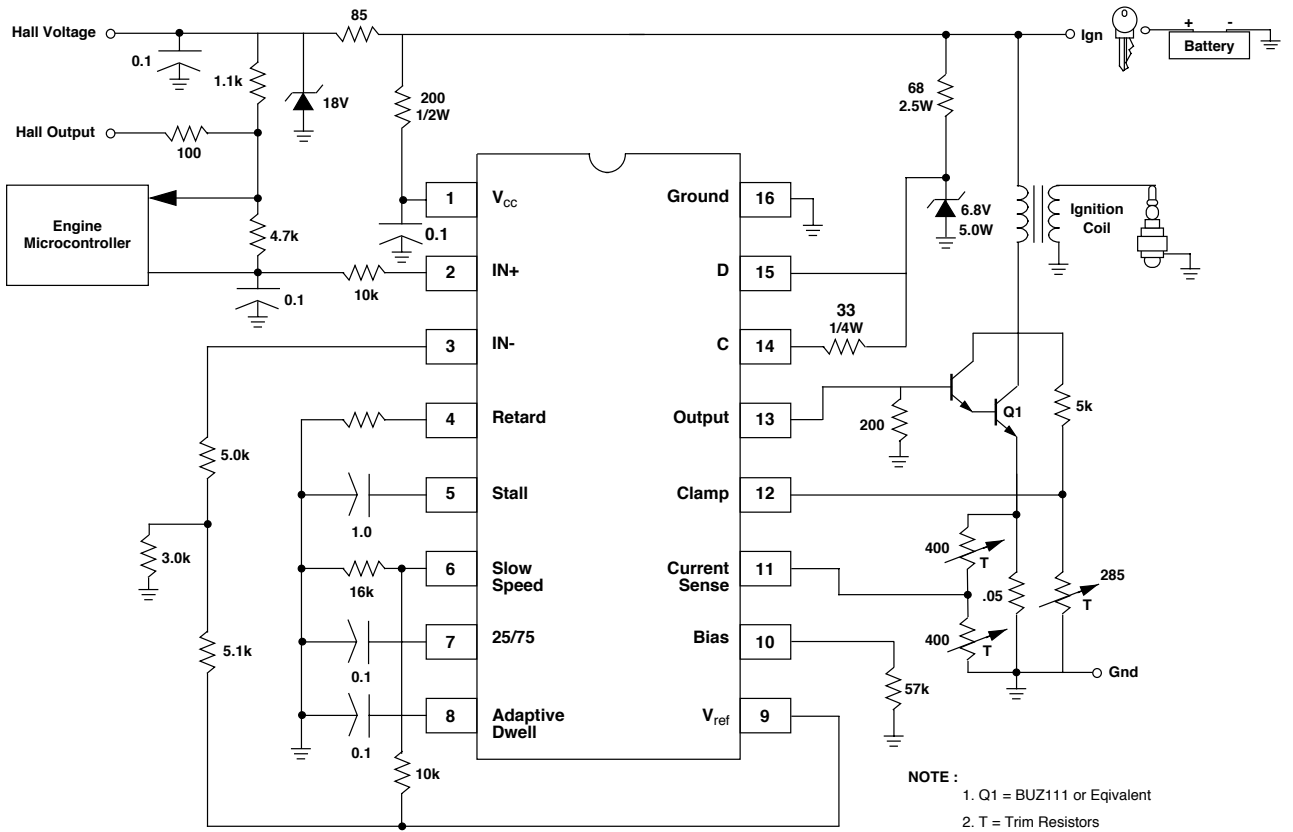

Figure 3. Application Circuit (Hall Sensor Input)



FUNCTIONNAL DESCRIPTION

Application /System Performances

1. Reluctance sensor input.
 - Minimum input level of 200mV peak to peak
 - Maximum input level of 40V peak to peak
2. Hall sensor input
 - Open collector output desirable.
 - Input level of 0.5V to V_{bat}
3. Operating voltage range
 - Normal range from 9V to 16V.
 - Operational range with some modifications to parameters from 6V to 24V.
4. Transient considerations
 - Load dumps should not exceed +90V peak with 250ms time constant.
 - Field decay should not exceed -90V peak with 25ms time constant.
5. Operating temperature range
 - Continuous operation : -30°C to 125°C
6. Rate of acceleration should not exceed 250Hz/s from 20Hz to 300Hz (input frequency). If this is exceeded the module will still function but an occasional spark may be missed and dwell calculations will be negated for one or two output cycles.
7. Normal operating frequency range is from 1Hz to 400Hz.

Application features and functions

1. Power on : On initial power up there will be no output current and this condition will be maintained until the first input cycle is run at the input terminals.
2. Push start capability : The unit may be push started as any input signal exceeding 200mV peak to peak will produce a peak
3. Stall shutdown : If for a period of 5 seconds no input signal is present, the unit will shutdown and output current will be reduced at a rate slow enough to present a spark.
4. Automatic switching from a slow speed to run mode at a preset frequency.

- No separate start wire into module is required
 - Switch occurs at approximately 12Hz but can be changed within a narrow region
5. Input noise immunity is provided by hysteresis on the input comparator.
 - 100mV of hysteresis is in slow speed mode
 - 500mV of hysteresis in run mode
 6. Dwell control is modified under different operating conditions.
 - In slow speed mode dwell follows the duty cycle of the input signal
 - In normal run mode dwell is controlled at 16% of cycle time plus coil rise time to current limit level.
 - At high speed (determined by coil rise time) dwell is 75% of input cycle time.
 7. Output current is normally 5.5 +/- 0.5 Amps. It can be operated at higher or lower limits if required. (Not excluding 7.5 Amps).
 8. Start Retard
 - On slow speed mode, a retard signal is generated that is inversely proportional to input frequency. The retard is nominally 4.8% at 1Hz, (related to input duty cycle) and can be modified to meet other application requirement.
 9. High voltage on the output transistor is nominally clamped at 350V but can be adjusted if necessary.
 10. High Battery voltage operation
 - At a battery voltage of 16V the dwell is modified in run speed to 10% of cycle time plus coil rise time.
 - At a battery voltage of approximately 30V the module will shutdown to prevent damages to the output devices.

Motorola reserves the right to make changes without further notice to any products herein. Motorola makes no warranty, representation or guarantee regarding the suitability of its products for any particular purpose, nor does Motorola assume any liability arising out of the application or use of any product or circuit, and specifically disclaims any and all liability, including without limitation consequential or incidental damages. "Typical" parameters which may be provided in Motorola data sheets and/or specifications can and do vary in different applications and actual performance may vary over time. All operating parameters, including "Typicals" must be validated for each customer application by customer's technical experts. Motorola does not convey any license under its patent rights nor the rights of others. Motorola products are not designed, intended, or authorized for use as components in systems intended for surgical implant into the body, or other applications intended to support or sustain life, or for any other application in which the failure of the Motorola product could create a situation where personal injury or death may occur. Should Buyer purchase or use Motorola products for any such unintended or unauthorized application, Buyer shall indemnify and hold Motorola and its officers, employees, subsidiaries, affiliates, and distributors harmless against all claims, costs, damages, and expenses, and reasonable attorney fees arising out of, directly or indirectly, any claim of personal injury or death associated with such unintended or unauthorized use, even if such claim alleges that Motorola was negligent regarding the design or manufacture of the part. Motorola and  are registered trademarks of Motorola, Inc. Motorola, Inc. is an Equal Opportunity/Affirmative Action Employer.