



DESCRIPTION

PT2270 is a remote control decoder paired with PT2260 or PT2262 utilizing CMOS Technology. It has 12-bit of tri-state address pins providing a maximum of 531,441 (or 3^{12}) address codes; thereby drastically reducing any code collision and unauthorized code scanning possibilities. PT2270 is available in several options to suit every application needs: variable number of data output pins, latch or momentary output type.

When paired with PT2260, this encoder/decoder (PT2260 / PT2270) pair can operate at very wide temperature range ($-40^{\circ}\text{C} \sim +85^{\circ}\text{C}$). See also PT2260 Product Specification Features. Thus, this very important feature enables your Encoder/Decoder to operate under the worst environmental condition.

FEATURES

- CMOS technology
- Low power consumption
- Very high noise immunity
- Up to 12 Tri-State code address pins
- Up to 6 data pins
- Operating voltage: $V_{CC}=2 \sim 10\text{V}$
- Single resistor oscillator
- Latch or momentary output type

APPLICATIONS

- Car security system
- Garage door controller
- Remote control fan
- Home security/Automation system
- Remote control toys
- Remote control for industrial use



BLOCK DIAGRAM

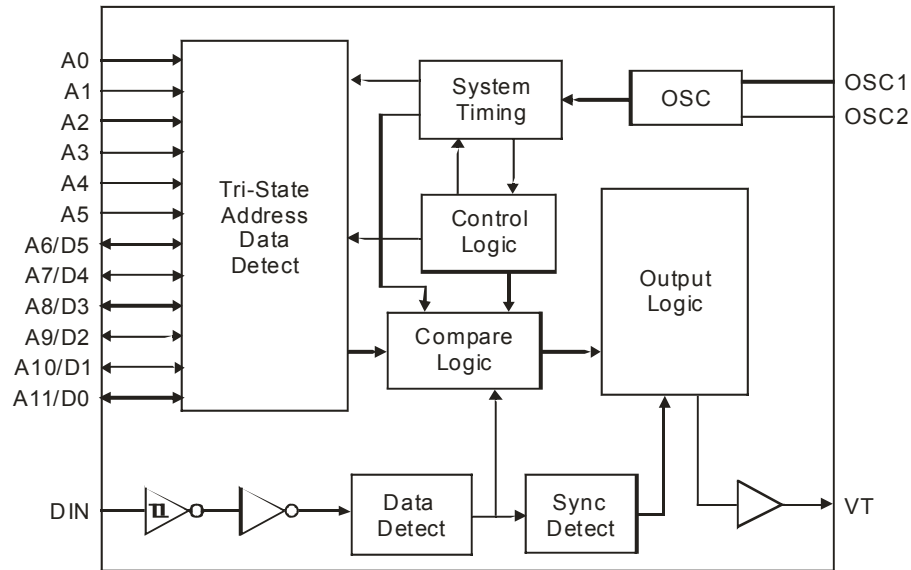



PIN CONFIGURATION

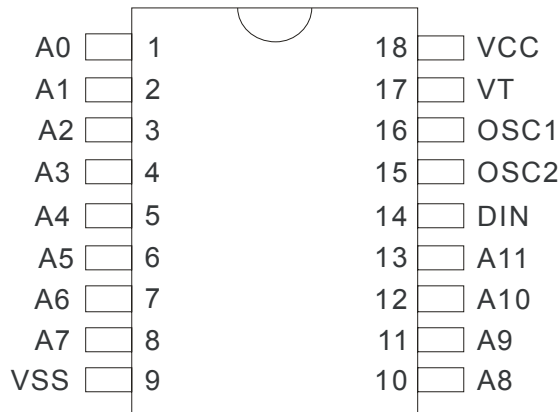

PT2270

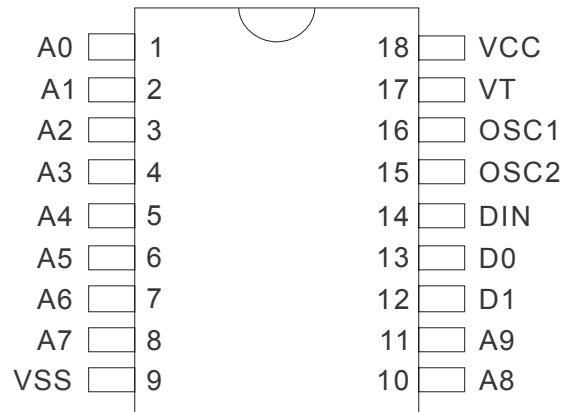

PT2270-M2/L2

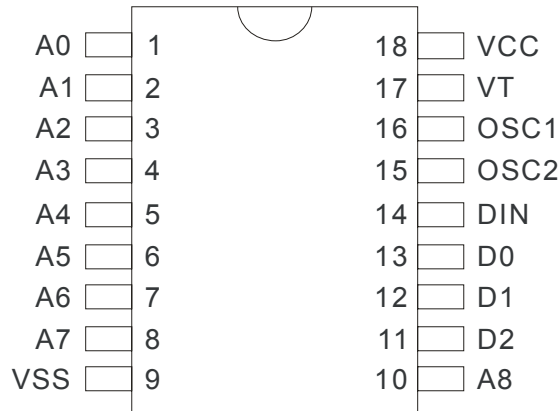

PT2270-M3/L3

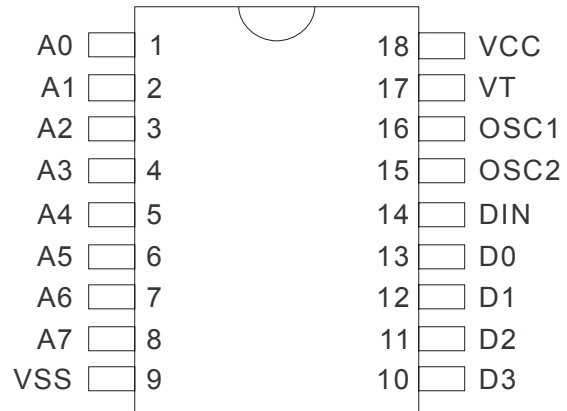

PT2270-M4/L4

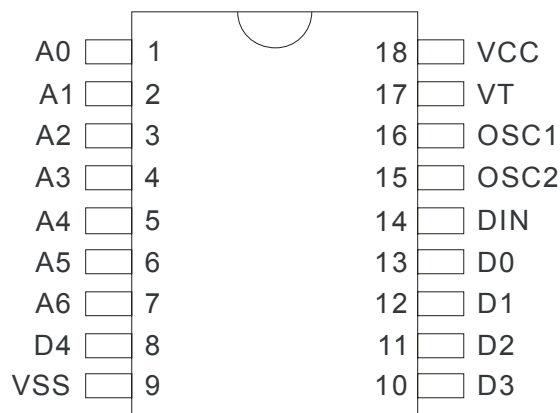

PT2270-M5/L5

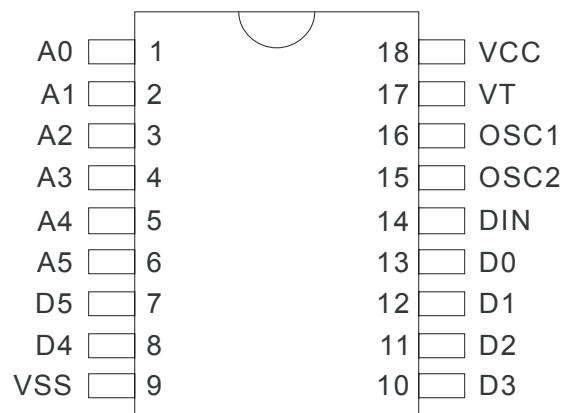

PT2270-M6/L6



PIN CONFIGURATION

Pin Name	I/O	Description	Pin No.
A0 ~ A5	I	Code Address Pin No. 0 ~ 5. These six tri-state pins are detected by PT2270 to determine the encoded waveform bit 0 ~ bit 5. Each pin can be set to "0", "1", or "f" (floating).	1 ~ 6
A6/D5 ~ A11/D0	I/O	Code Address Pin No. 6 ~ 11/Data Pin No. 5 ~ 0. These six pins are used as higher address input bits or data output pins depending on the version (type) of PT2270 used. When used as address inputs, these pins are tri-state input pins and each pin can be set to "0", "1", or "f" (floating). When used as output pins, these pins are driven to V_{CC} if (1) the address decoded from the waveform that was received matches the address setting at the address input pins, and (2) the corresponding data bits received is a "1" bit. Otherwise, they are driven to V_{SS} .	7 ~ 8 10 ~ 13
DIN	I	Data Input Pin. The encoded waveform received is serially fed to PT2270 at this pin.	14
OSC 1	I	Oscillator Pin No.1	A resistor connected between these two pins determine the fundamental frequency of PT2270.
OSC 2	O	Oscillator Pin No. 2	
VT	O	Valid Transmission. Active High Signal. VT in high state signifies that PT2270 receives valid transmission waveform.	17
V_{CC}	-	Positive Power Supply	18
V_{SS}	-	Negative Power Supply	9



FUNCTION DESCRIPTION

PT2270 decodes the waveform received and fed into the DIN pin. The Waveform is decoded into code word that contains the address, data and sync bits. The decoded address bits are compared with the address set at the address input pins. If both addresses match for 2 consecutive code words, PT2270 drives -- (1) the data output pin(s) whose corresponding data bit(s) is then decoded to be a "1" bit, and (2) the VT output -- to high voltage (high state).

CODE BITS

A Code Bit is the basic component of the encoded waveform, and can be classified as either an AD (Address/Data) Bit or a SYNC (Synchronous) Bit.

ADDRESS/DATA (AD) BIT WAVEFORM

An AD Bit can be designated as Bit "0", "1" or "f" if it is in low, high or floating state respectively. One bit waveform consists of 2 pulse cycles. Each pulse cycle has 16 oscillating time periods. For further details, please refer to the diagram below:

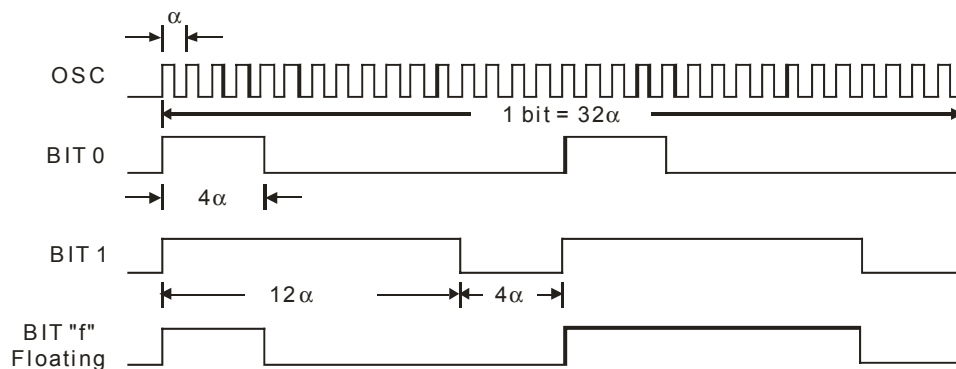

Where:

1. α = Oscillating Clock Period
2. Bit "f" is only available for address bits

SYNCHRONOUS (SYNC.) BIT WAVEFORM

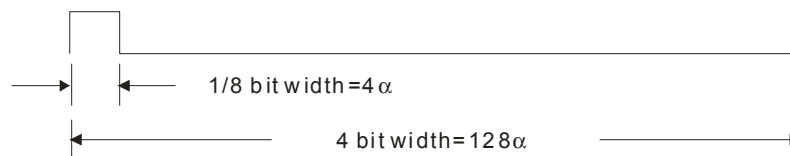

Note: 1-bit = 32α



CODE WORD

A group of Code Bits is called a Code Word. A Code Word consists of 12 AD bits followed by one Sync Bit. The 12 AD bits are interpreted as either address or data bits depending on the PT2270 version used. Please refer to the diagrams below.

PT2270:

A0	A1	A2	A3	A4	A5	A6	A7	A8	A9	A10	A11	SYNC
----	----	----	----	----	----	----	----	----	----	-----	-----	------

PT2270-M2/L2:

A0	A1	A2	A3	A4	A5	A6	A7	A8	A9	D1	D0	SYNC
----	----	----	----	----	----	----	----	----	----	----	----	------

PT2270-M3/L3:

A0	A1	A2	A3	A4	A5	A6	A7	A8	D2	D1	D0	SYNC
----	----	----	----	----	----	----	----	----	----	----	----	------

PT2270-M4/L4:

A0	A1	A2	A3	A4	A5	A6	A7	D3	D2	D1	D0	SYNC
----	----	----	----	----	----	----	----	----	----	----	----	------

PT2270-M5/L5:

A0	A1	A2	A3	A4	A5	A6	D4	D3	D2	D1	D0	SYNC
----	----	----	----	----	----	----	----	----	----	----	----	------

PT2270-M6/L6:

A0	A1	A2	A3	A4	A5	D5	D4	D3	D2	D1	D0	SYNC
----	----	----	----	----	----	----	----	----	----	----	----	------





SINGLE RESISTOR OSCILLATOR

The built-in oscillator circuitry of PT2270 allows a precision oscillator to be constructed with only an external resistor. For the PT2270 to decode correctly the waveform that was received, the oscillator frequency of PT2270 must be 1/16 ~ 4 (or 2 to 30) times that of the transmitting PT2260 (or PT2262). It is a good practice to center the PT2270 oscillator frequency in this window to gain best window margin at both sides. The typical oscillator with various resistor values are shown below for PT2260, PT2262 and PT2270.

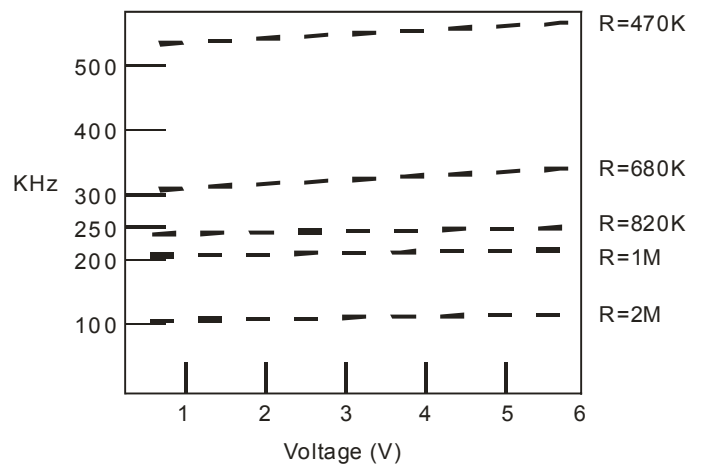
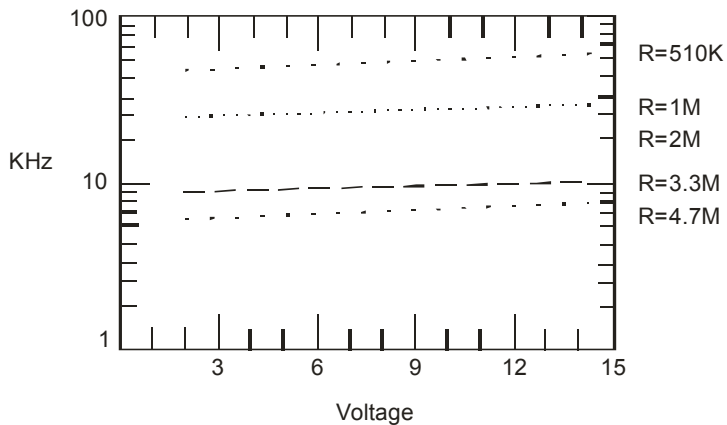

PT2262 Encoder OSC Frequency

PT2260 Encoder OSC Frequency

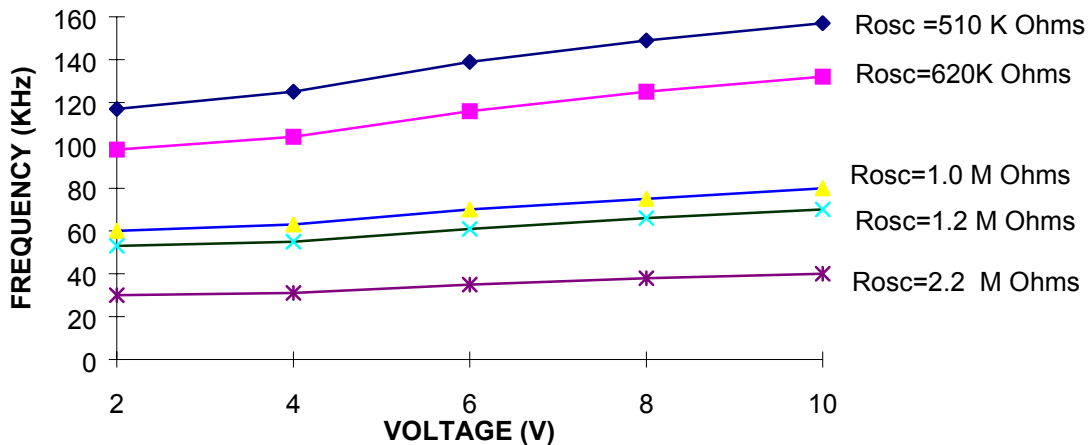

PT2270 Decoder OSC Frequency

Suggested oscillator resistor values are shown below.

PT2260	PT2270
820KΩ	1.0MΩ
1.0MΩ	1.2MΩ
2.0MΩ	2.2MΩ

PT2262	PT2270
1.2MΩ	120KΩ
1.5MΩ	160KΩ
3.3MΩ	390KΩ



VALID TRANSMISSION

When PT2270 receives a transmission code word, it initially checks whether this is a valid transmission. For a transmission to be valid, (1) it must be a Complete Code Word, and (2) the Address Bits must match the Address Setting at the Address Pins. After two consecutive valid transmissions, PT2270 (1) drives the data pins according to the data bits received, and (2) raises VT to high voltage (high state).

The timings are shown in the following diagram.

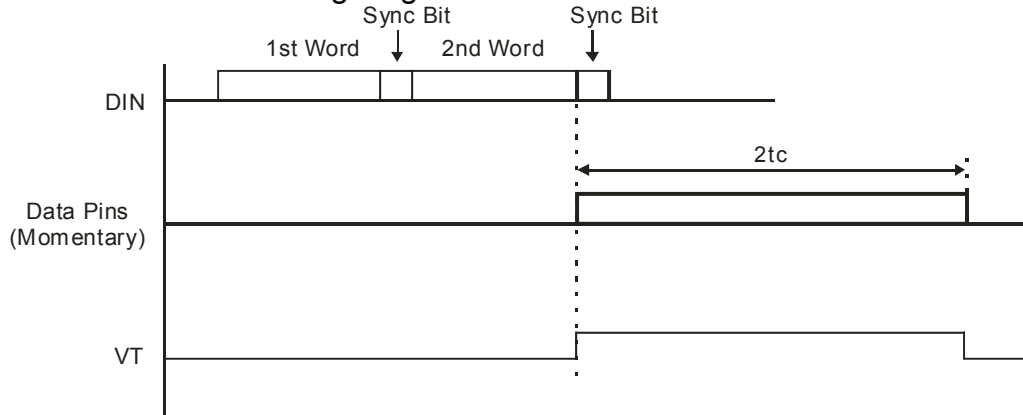

Note: tc = Width of 1 Code Word

LATCH OR MOMENTARY DATA OUTPUT TYPE

PT2270 uses either the latch or the momentary data output type depending on the PT2270 version used. The latch type (PT2270-Lx) activates the data out during transmission and this data is sustained in the memory until another data is inputted or entered. A momentary type (PT2270-Mx), on the other hand, activates the data out only during transmission. In the momentary type, the data does not remain in the memory after the transmission is completed. Please refer to the diagram below.

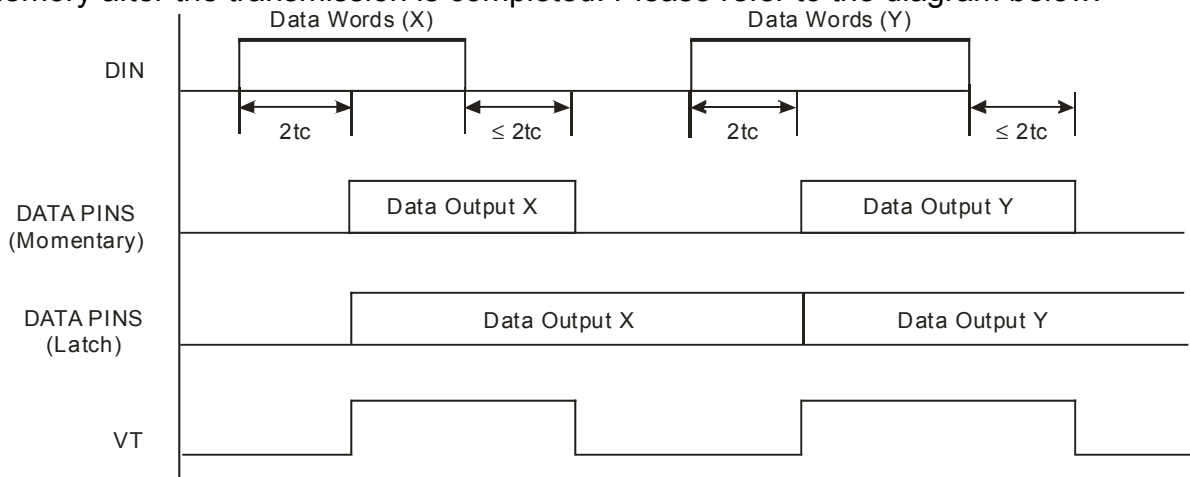

Note: tc = Width of 1 Code Word



OPERATION FLOWCHART

DECODER WITHOUT DATA OUTPUT PIN

1. When Power is turned on, PT2270 activates the Stand-By Mode.
2. It then searches for signals. If there is no signal received, it remains in the Stand-By Mode; otherwise, the address bits received are compared with the address configuration of the pins.
3. The VT goes high signifying the validation of transmission only when there are two (2) continuous frames that contain matched address bits; otherwise, VT will not be activated and the Stand-By Mode remains active.
4. Then, the Address Bits are again checked. Two continuous mismatches of the address bits would disable the VT and make the Stand-By Mode active; otherwise, the address bits are continuously checked.

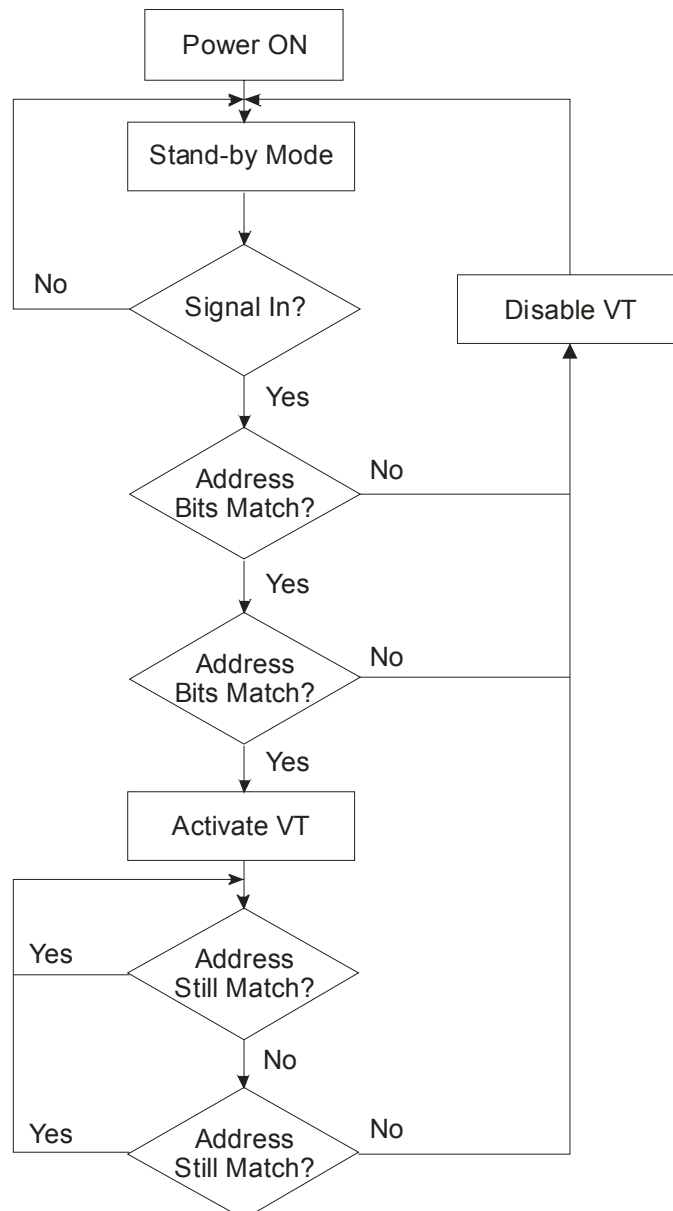



DECODER WITH DATA OUTPUT PINS

1. When Power is turned ON, PT2270 activates the Stand-By Mode.
2. It then searches for signals. If there is no signal received, it remains in the Stand-By Mode; otherwise, the address bits are compared with the address configuration of the pins.
Whenever the Address Bits in a Frame match with that of the Address Configuration of the Pin, the data bits are stored into the memory. When the result is a match, it then undergoes another matching (Address Bits in the Frame vs. Address Configuration of the Pin) and storing (data bits stored in the memory) process.
When this IC finds two (2) continuous and identical data having the same address bits, the data output(s) is activated and the VT is enabled. The VT is disabled when there are 2 continuous mismatched addresses. For the momentary type, the data output is reset; while for the latch type, the data output is sustained.



Remote Control Decoder IC

PT2270

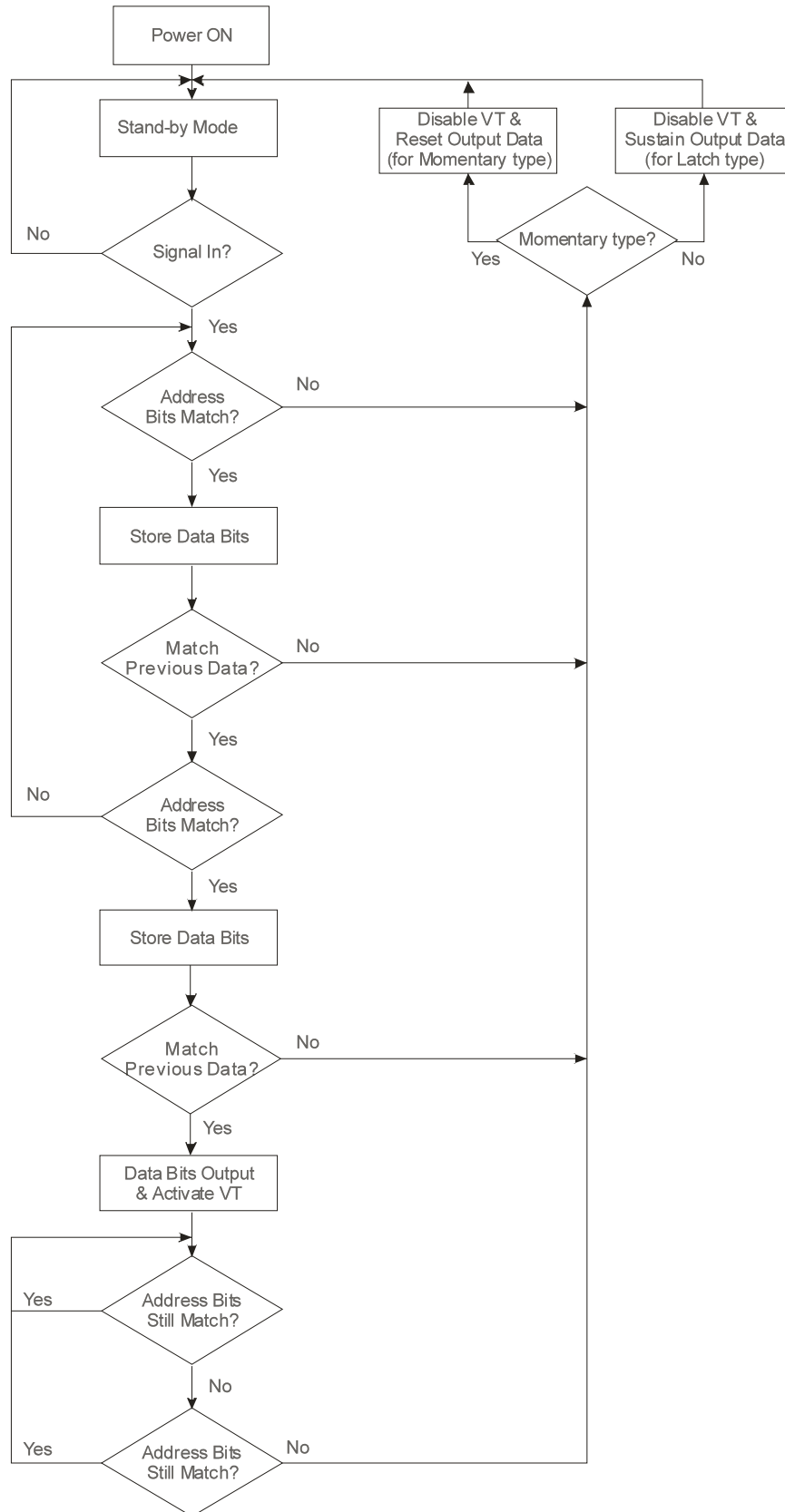



ABSOLUTE MAXIMUM RATINGS

Parameter	Symbol	Rating	Unit
Operating temperature	Topr	-40 ~ +85	°C
Storage temperature	Tstg	-65 ~ +150	°C

DC ELECTRICAL CHARACTERISTICS

Parameter	Symbol	Min.	Typ.	Max.	Unit
Supply voltage	V _{CC}	2.0	5.0	10.0	V
Standby current	I _{SB}		0.1	1	μA
D0~D5 output driving current	I _{OH}	3	5		mA
D0~D5 output sinking current	I _{OL}	-2	-4		mA
DIN high level input voltage	V _{IH}	0.7V _{CC}		V _{CC}	V
DIN low level input voltage	V _{IL}	0		0.3V _{CC}	V
VT output driving current	I _{OH}	3	6		mA



APPLICATION CIRCUIT

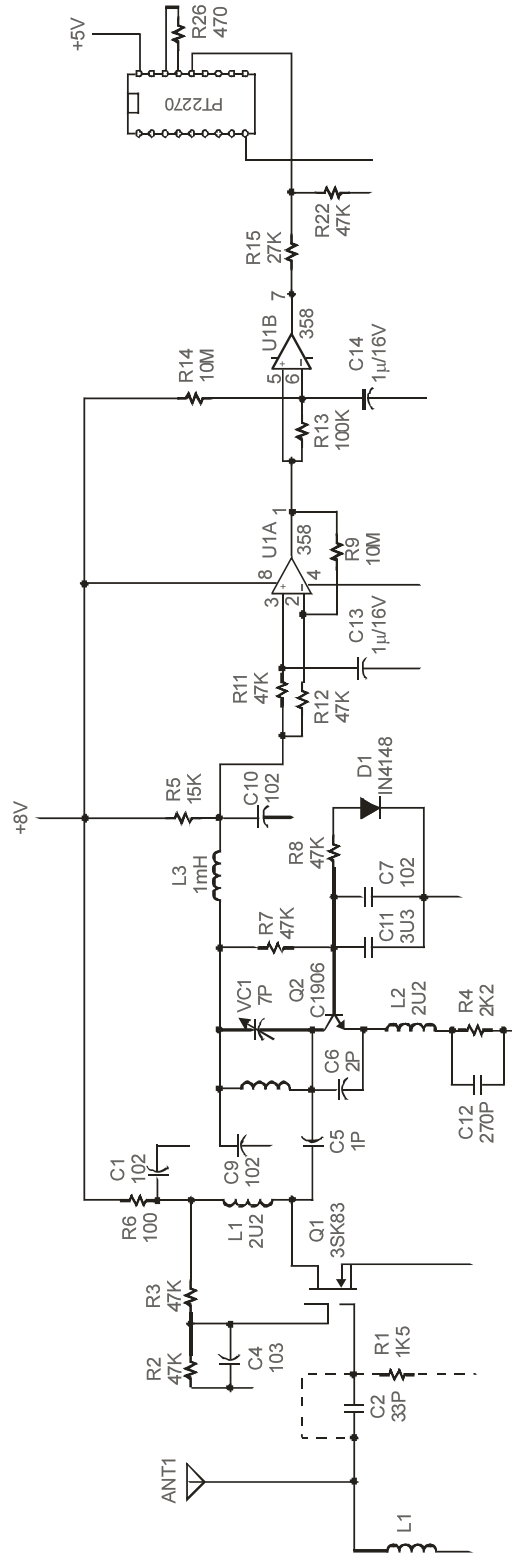



ORDER INFORMATION

Valid Part Number	Package Type	Top Code
PT2270	18 Pins, DIP, 300mil	PT2270
PT2270-L2	18 Pins, DIP, 300mil	PT2270-L2
PT2270-M2	18 Pins, DIP, 300mil	PT2270-M2
PT2270-L3	18 Pins, DIP, 300mil	PT2270-L3
PT2270-M3	18 Pins, DIP, 300mil	PT2270-M3
PT2270-L4	18 Pins, DIP, 300mil	PT2270-L4
PT2270-M4	18 Pins, DIP, 300mil	PT2270-M4
PT2270-L5	18 Pins, DIP, 300mil	PT2270-L5
PT2270-M5	18 Pins, DIP, 300mil	PT2270-M5
PT2270-L6	18 Pins, DIP, 300mil	PT2270-L6
PT2270-M6	18 Pins, DIP, 300mil	PT2270-M6
PT2270-S	18 Pins, SOP, 300mil	PT2270-S
PT2270-L2S	18 Pins, SOP, 300mil	PT2270-L2S
PT2270-M2S	18 Pins, SOP, 300mil	PT2270-M2S
PT2270-L3S	18 Pins, SOP, 300mil	PT2270-L3S
PT2270-M3S	18 Pins, SOP, 300mil	PT2270-M3S
PT2270-L4S	18 Pins, SOP, 300mil	PT2270-L4S
PT2270-M4S	18 Pins, SOP, 300mil	PT2270-M4S
PT2270-L5S	18 Pins, SOP, 300mil	PT2270-L5S
PT2270-M5S	18 Pins, SOP, 300mil	PT2270-M5S
PT2270-L6S	18 Pins, SOP, 300mil	PT2270-L6S
PT2270-M6S	18 Pins, SOP, 300mil	PT2270-M6S



PACKAGE INFORMATION

18 PINS, DIP, 300MIL

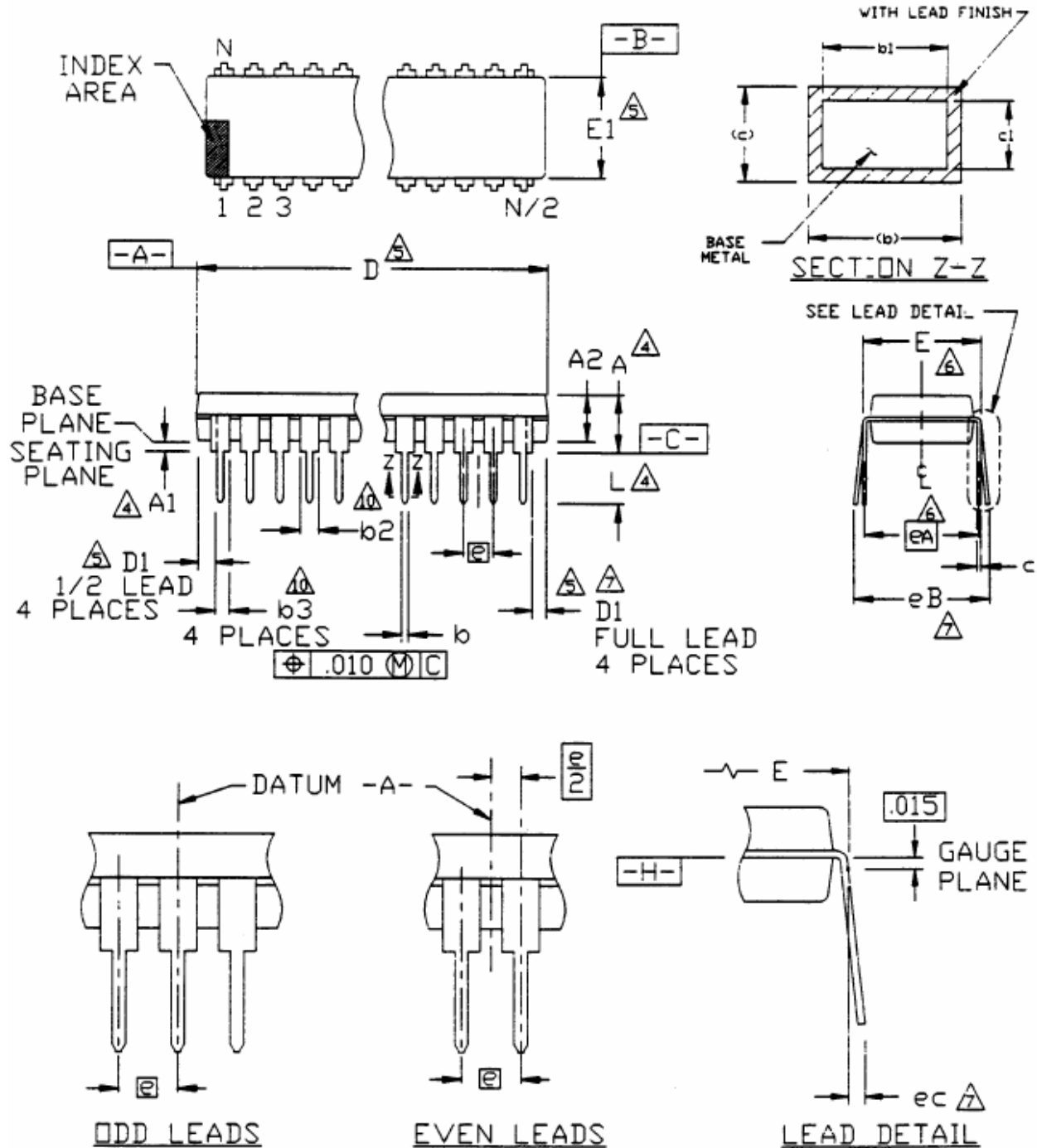



Symbol	Min.	Nom.	Max.
A			0.210
A1	0.015		
A2	0.115	0.130	0.195
b	0.014	0.018	0.022
b1	0.014	0.018	0.020
b2	0.045	0.060	0.070
b3	0.030	0.039	0.045
c	0.008	0.010	0.014
c1	0.008	0.010	0.011
D	0.880	0.900	0.920
D1	0.005		
E	0.300	0.310	0.325
E1	0.240	0.250	0.280
e	0.100 bsc.		
eA	0.300 bsc.		
eB			0.430
eC	0.000		0.060
L	0.115	0.130	0.150

Notes:

- All dimensions are in INCHS.
- Dimensioning and tolerancing per ANSI Y14.5M-1982.
- Dimensions "A", "A1" and "L" are measured with the package seated in JEDEC Seating Plane Gauge GS-3.
- "D", "D1" and "E1" dimensions do not include mold flash or protrusions. Mold flash or protrusions shall not exceed 0.010 inch.
- "E" and "eA" measured with the leads constrained to be perpendicular to datum $\square C$.
- "eB" and "eC" are measured at the lead tips with the loads unconstrained.
- "N" is the number of terminal positions. (N=18)
- Pointed or rounded lead tips are preferred to ease insertion.
- "b2" and "b3" maximum dimensions are not include dambar protrusions. Dambar protrusions shall not exceed 0.010 inch (0.25 mm).
- Distance between leads including Dambar protrusions to be 0.005 inch minimum.
- Datum plane $\square H$ coincident with the bottom of lead, where lead exits body.
- Refer to JEDEC MS-001 Variation AC.

JEDEC is the trademark of JEDEC SOLID STATE TECHNOLOGY ASSOCIATION.



Remote Control Decoder IC

PT2270

18 PINS, SOP, 300MIL

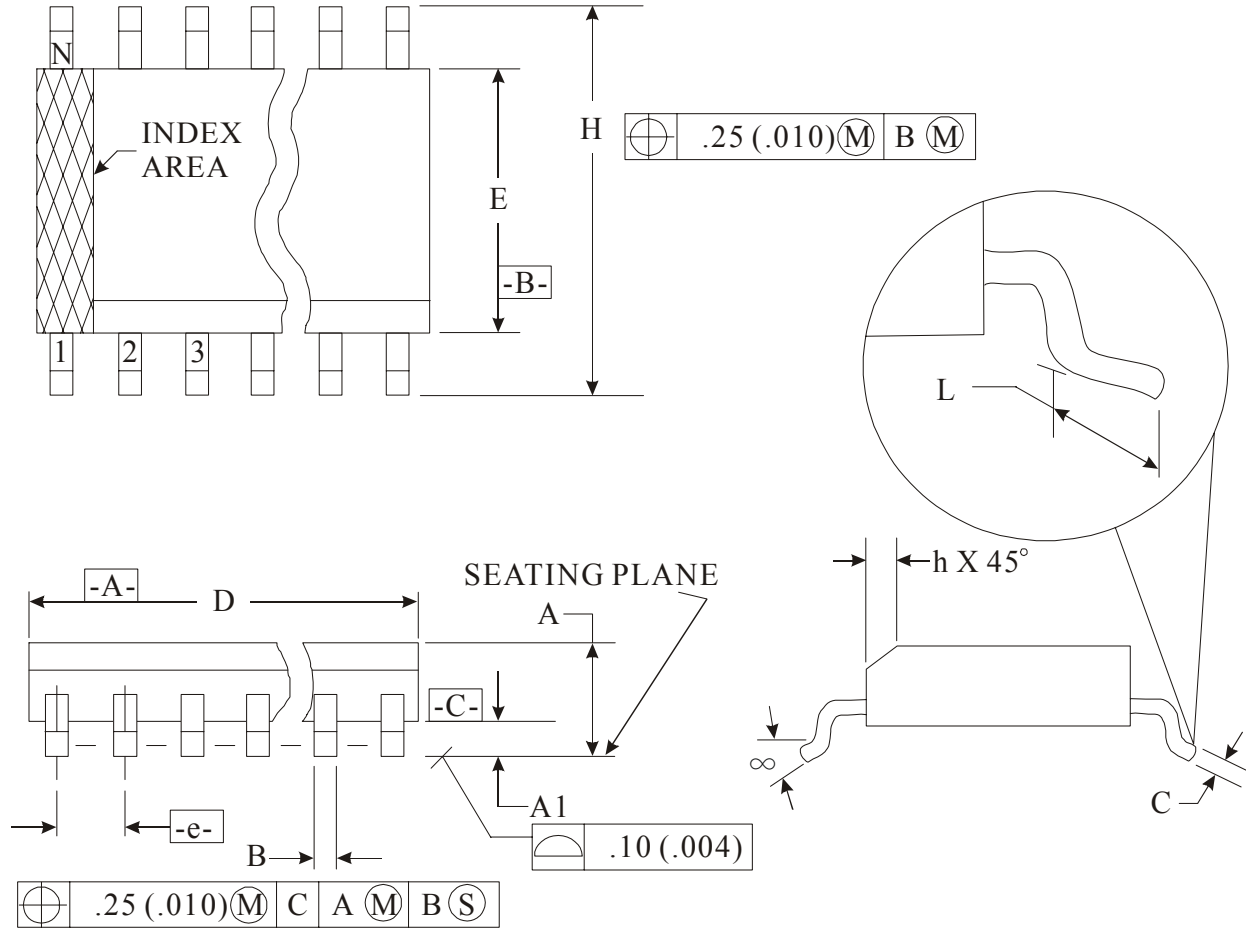

Symbol	Min.	Nom.	Max.
A	2.35		2.65
A1	0.10		0.30
B	0.33		0.51
C	0.23		0.32
D	11.35		11.75
E	7.40		7.60
e		1.27 bsc.	
H	10.00		10.65
h	0.25		0.75
L	0.40		1.27
α	0°		8°



Remote Control Decoder IC

PT2270

Notes:

1. Dimensioning and tolerancing per ANSI Y14.5M-1982.
 2. Dimension "D" does not include mold flash, protrusions or gate burrs. Mold Flash, protrusion or gate burrs shall not exceed 0.15 mm (0.006 in) per side.
 3. Dimension "E" does not include interlead flash or protrusions. Interlead flash or protrusions shall not exceed 0.25 mm (0.010 in) per side.
 4. The chamfer on the body is optional. If it is not present, a visual index feature must be located within the crosshatched area.
 5. "L" is the length of the terminal for soldering to a substrate.
 6. N is the number of the terminal positions (N=18)
 7. The lead width "B" as measured 0.36 mm (0.014 in) or greater above the seating plane, shall not exceed a maximum value of 0.61 mm (0.24 in).
 8. Controlling dimension: MILLIMETER.
 9. Refer to JEDEC MS-013, Variation AB.
- JEDEC is the trademark of JEDEC SOLID STATE TECHNOLOGY ASSOCIATION.