

710-017 Non-Environmental Bulkhead Fitting for Series 72 Annular Convulsated Tubing

TYPE A

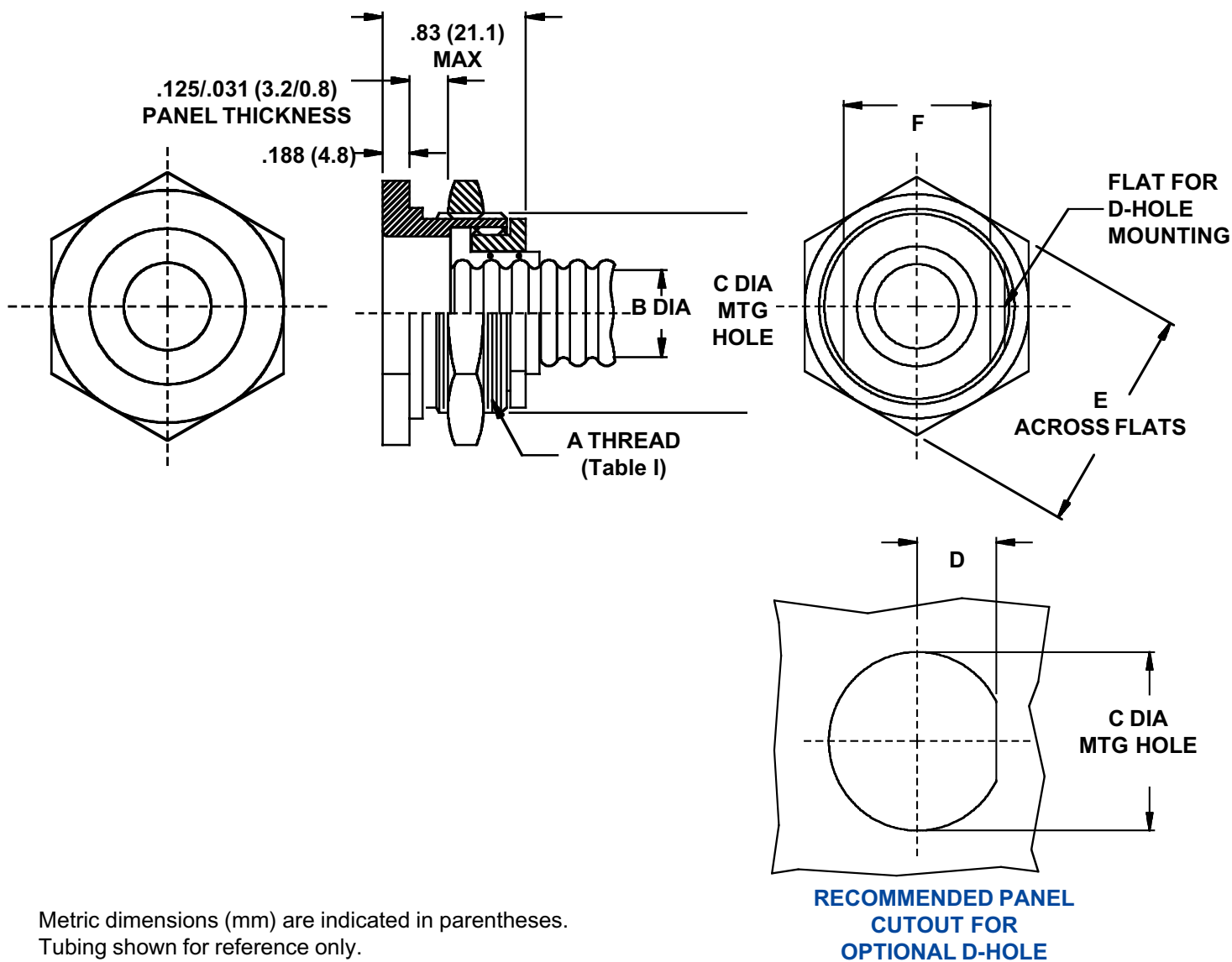
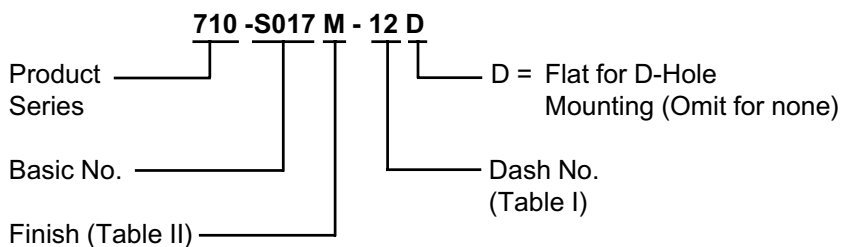

Metric dimensions (mm) are indicated in parentheses.
Tubing shown for reference only.

710-017
Non-Environmental Bulkhead Fitting
for Series 72 Annular Convuluted Tubing



TABLE I

DASH NO.	A THREAD CLASS 2A	B INSIDE DIA		C		D	E REF	F
		MIN	MAX	+0.015 (+0.4) -0.005 (-0.1)	+0.010 (+0.3) .000 (0.0)			
09	7/8 - 20 UNEF	.24 (6.1)	.28 (7.1)	.885 (22.5)	.380 (9.7)	1.062 (27.0)	.69 (17.5)	
12	1 1/16 - 18 UNEF	.33 (8.4)	.37 (9.4)	1.072 (27.2)	.474 (12.0)	1.250 (31.8)	.88 (22.4)	
16	1 3/16 - 18 UNEF	.45 (11.4)	.50 (12.7)	1.198 (30.4)	.536 (13.6)	1.375 (34.9)	1.00 (25.4)	
20	1 5/16 - 18 UNEF	.57 (14.5)	.62 (15.7)	1.322 (33.6)	.599 (15.2)	1.500 (38.1)	1.12 (28.4)	
24	1 1/2 - 18 UNEF	.69 (17.5)	.75 (19.1)	1.510 (38.4)	.693 (17.6)	1.750 (44.5)	1.25 (31.8)	
28	1 11/16 - 18 UNEF	.81 (20.6)	.87 (22.1)	1.698 (43.1)	.786 (20.0)	1.875 (47.6)	1.44 (36.6)	
32	1 7/8 - 16 UN	.93 (23.6)	1.00 (25.4)	1.885 (47.9)	.880 (22.4)	2.125 (54.0)	1.62 (41.1)	
40	2 1/8 - 16 UN	1.18 (30.0)	1.25 (31.8)	2.135 (54.2)	1.005 (25.5)	2.375 (60.3)	1.82 (46.2)	

TABLE II

SYMBOL	FINISH
B	Olive Drab over Cadmium Plate
J	Gold Iridite over Cadmium Plate over Nickel
M	Electroless Nickel
N	Olive Drab over Cadmium Plate over Nickel
NC	Zinc-Cobalt, Olive Drab
NF	Olive Drab over Cadmium Plate over Electroless Nickel (500 Hour Salt Spray)
T	Bright Dip Cadmium Plate over Nickel

Metric dimensions (mm) are indicated in parentheses.