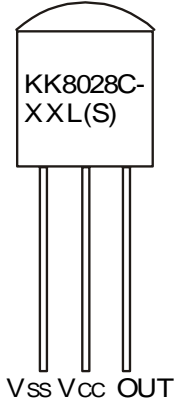

SIMPLE MELODY GENERATOR

KK8028-XX

FEATURES	FUNCTIONS	
<ul style="list-style-type: none"> • 127-note ROM memory • 1.3V to 3.3V power supply and low power consumption • RC oscillator on chip • One shot or level hold mode • Sound range: 4 octaves, 2 series • Tempo: 16 kinds (presto-largo) • Direct piezo drive 	<ul style="list-style-type: none"> • Solution of automatic stop or repeat of the melody • Dynamic speaker can be driven with external NPN transistor • Two or three times repeat of melody (mask option) • Each note can be individually programmed to be staccato or legato (mask option) • Changing the contents of melody is possible by reprogramming the maskable ROM • Power on reset; melody begins from the first note • Start from the head of melody • Bare chip or TO-92 are available 	

DESCRIPTION

The KK8028 is a CMOS LSI chip which electronically plays a prearranged melody. Selection of melody start signal is possible by mask option: orders specification suffix "L" indicate Level Hold Mode, and suffix "S" indicate One Shot Mode. The Universal version (as One Shot or Level Hold Mode) is possible also (suffix "U").

ABSOLUTE MAXIMUM RATINGS (Ta = 25°C)

Characteristic	Symbol	Value	Unit
DC Supply Voltage	$V_{CC} - V_{SS}$	-0.3 ~ 3.5	V
Input Voltage	V_{IN}	$V_{SS} - 0.3 \sim V_{CC} - 0.3$	V
Operating Temperature	T_{opr}	-20 ~ +65	°C
Storage Temperature	T_{stg}	-55 ~ +125	°C

ELECTRICAL CHARACTERISTICS (Ta = 25°C, VCC = 1.5V; unless otherwise specified)

Characteristic	Symbol	Test Condition	Min	Typ	Max	Unit
Operating Voltage	V_{CC}		1.3	1.5	3.3	V
Supply Current	Stand-by	I_S		0.1	1	μA
Output Drive Current	I_{OH}	$V_{CC} = 1.3V, V_O = 0.8V$	0.6	1.5		mA
Output Sink Current	I_{OL}	$V_{CC} = 1.3V, V_O = 0.5V$	0.6	1.5		mA
Frequency Stability	$\Delta F/F$	$F_{osc}(1.6V) - F_{osc}(1.3V)$			12	%
		$F_{osc}(1.3V)$				

APPLICATION CIRCUITS

LEVEL HOLD

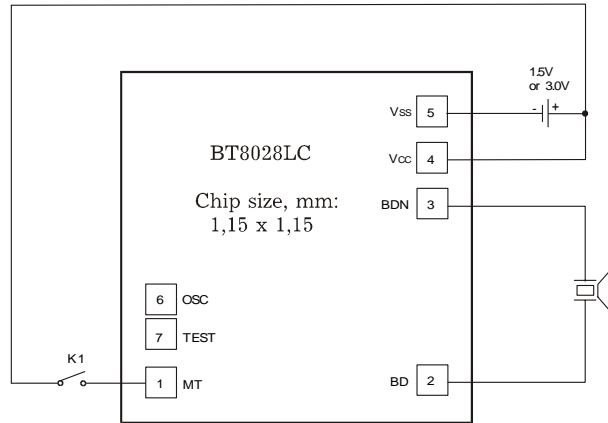
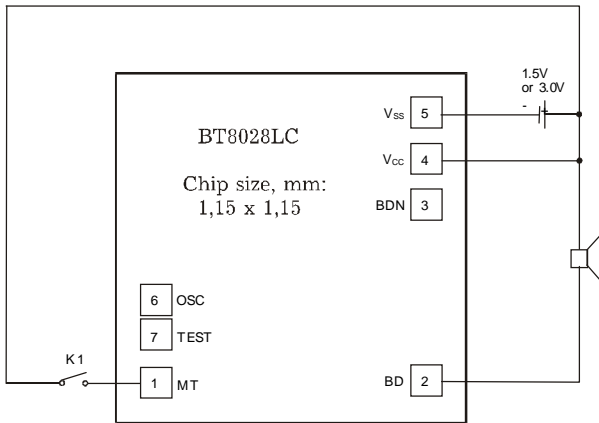

ONE SHOT

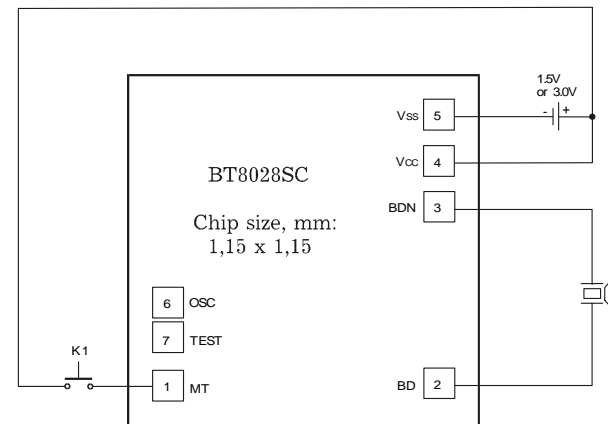
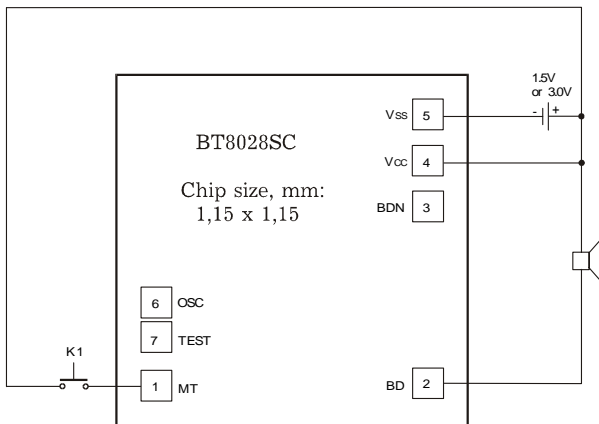

TO-92 ONE SHOT OR LEVEL HOLD MODE

CHIP FORM

FOR SPEAKER

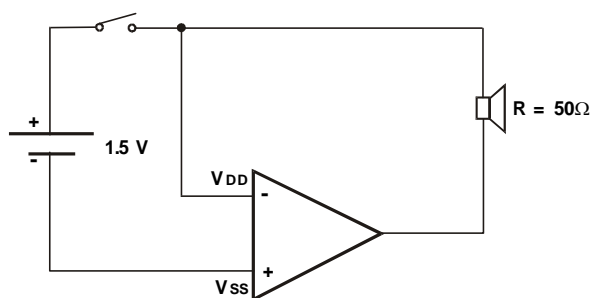

FOR PIEZO

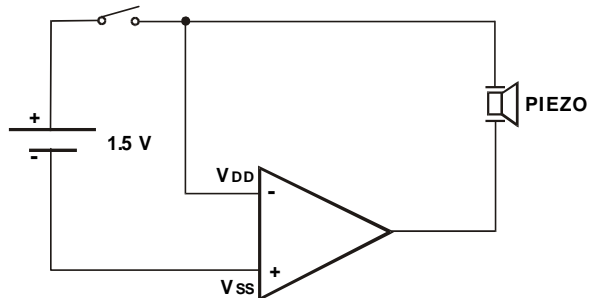

AVAILABLE SONG LIST

NEW EXT No.	SONG LIST	SEC
KK8028C-001	For Elise	13
KK8028C-002	Staff WRK	
KK8028C-003	Happy Birthday	13
KK8028C-004	Jingle Bell	12
KK8028C-005	It's Small World	21
KK8028C-006	3 Children Song	13
KK8028C-007	Cuocoo Waltz	10
KK8028C-008	London Bridge is Falling Down	16
KK8028C-009	Trainis Running Fast	11
KK8028C-010	Love Me Tender Love Me True	38
KK8028C-011	Love Story	23
KK8028C-012	Old McDonald Had a Farm	25
KK8028C-013	Jingle Bell/Santa Claus Is Coming to Town/ We Wish You a Merry X'mas	28
KK8028C-014	You are My Sunshine	12
KK8028C-015	Santa Claus is Coming To Town	20
KK8028C-016	Silent Night	26
KK8028C-017	Twinkle Twinkle Little Star	14
KK8028C-053	Car Alarm	

PAD LAYOUT

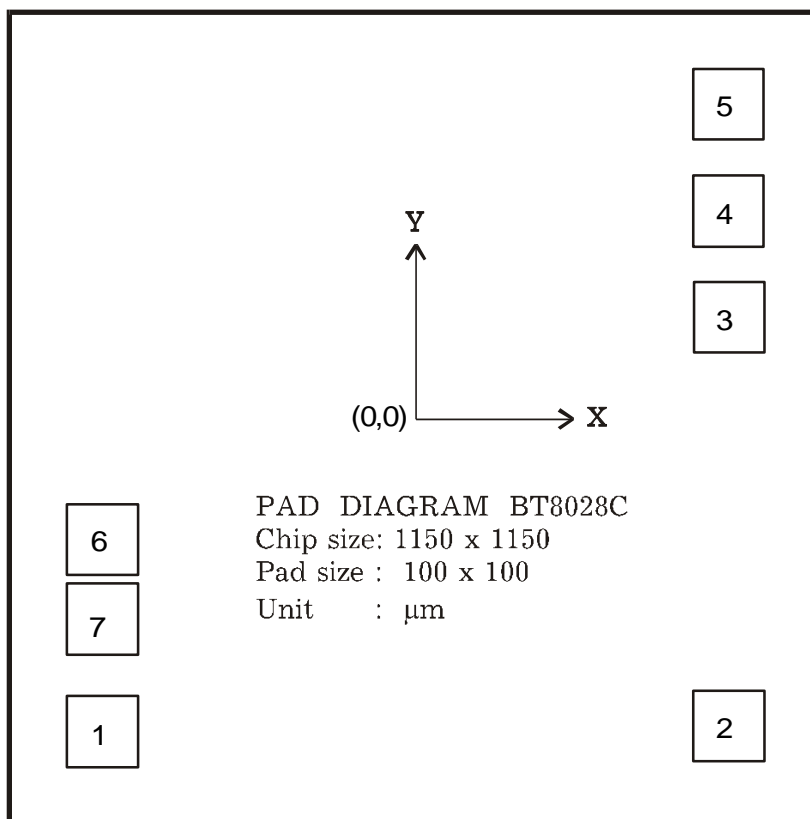

NOTE: Substrate is connected to V_{CC} .

PAD LOCATION

Pad No.	Designation	X	Y	Description
1	MT	-445	-445	Melody Start Input
2	BD	445	-435	Melody Output 1
3	BDN	445	145	Melody Output 2
4	V_{CC}	445	295	Positive Power Supply
5	V_{SS}	445	445	Negative Power Supply
6	OSC	-445	-282	Test Pad
7	TEST	-445	-169	Test Pad

• **TO-92**

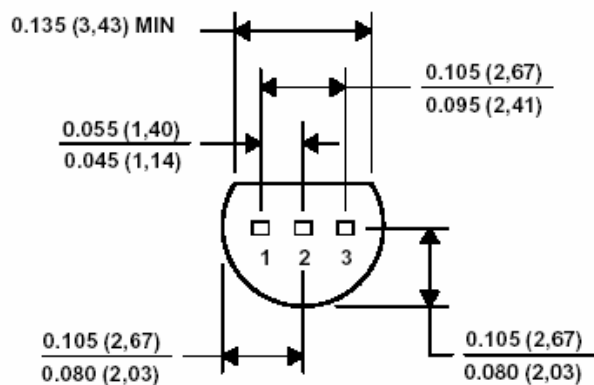
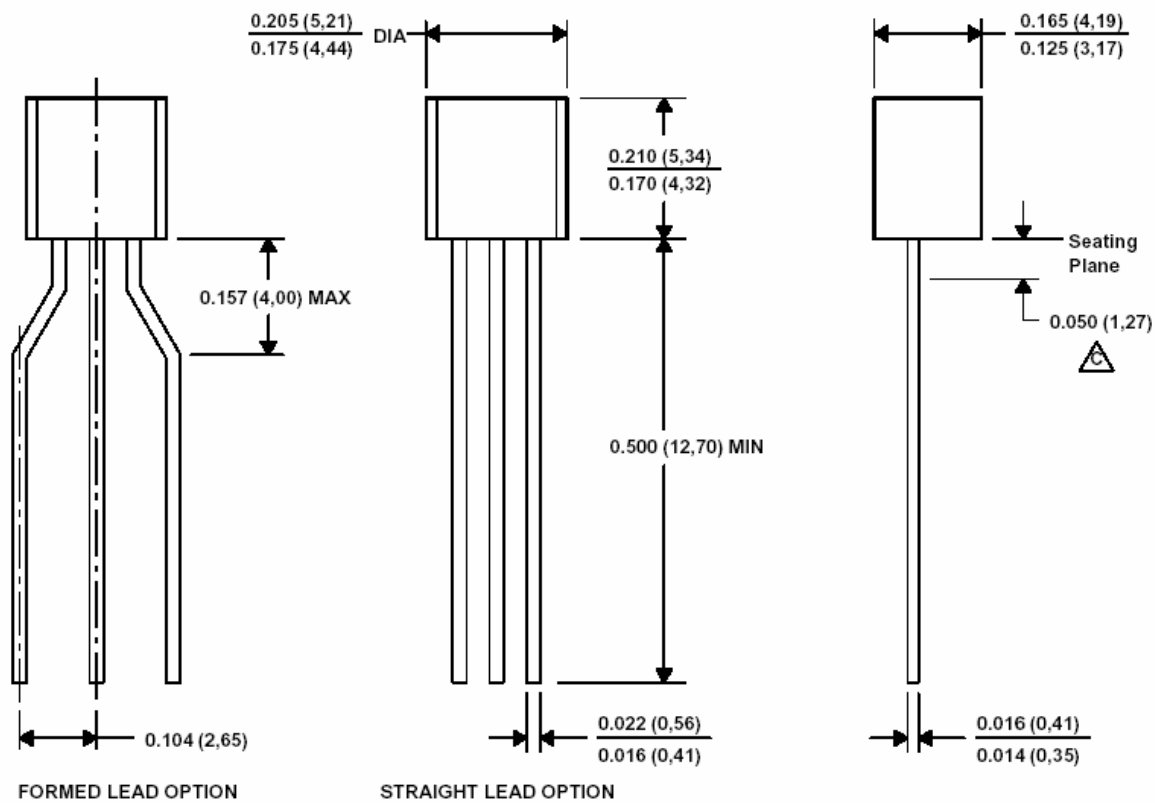

N SUFFIX PLASTIC DIP (MS - 001BA)

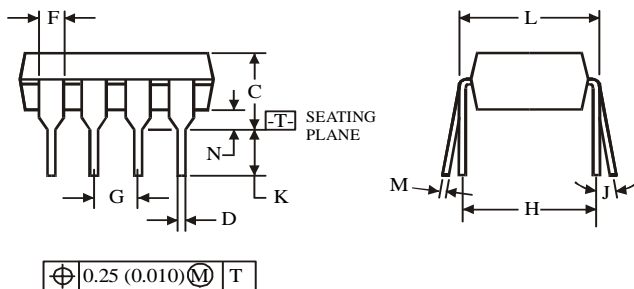
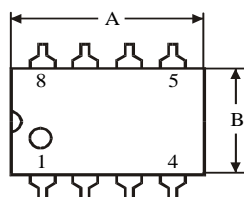
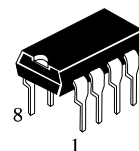

Symbol	Dimension, mm	
	MIN	MAX
A	8.51	10.16
B	6.1	7.11
C		5.33
D	0.36	0.56
F	1.14	1.78
G	2.54	
H	7.62	
J	0°	10°
K	2.92	3.81
L	7.62	8.26
M	0.2	0.36
N	0.38	

NOTES:

- Dimensions "A", "B" do not include mold flash or protrusions.
Maximum mold flash or protrusions 0.25 mm (0.010) per side.