

**PLEASE CHECK WWW.MOLEX.COM FOR LATEST PART INFORMATION**

**Part Number:** **0191640318**  
**Status:** **Active**  
**Description:** Perma-Seal™ Ring Tongue Terminal for 10-12 AWG Wire, Stud 5/16, Mylar Tape Carrier

**Documents:**

[Drawing \(PDF\)](#) [RoHS Certificate of Compliance \(PDF\)](#)

**Agency Certification**

CSA LR18689  
 UL E32244

**General**

Product Family Ring and Spade Terminals  
 Series 19164  
 Crimp Quality Equipment Yes  
 Mil-Spec N/A  
 Product Name Perma-Seal™  
 Type Ring

**Physical**

Barrel Type Closed  
 Flammability 94V-2  
 Insulation NiAc™  
 Material - Plating Mating Tin  
 Packaging Type Adhesive Tape on Reel  
 Stud Size 5/16" (M8)  
 Wire Insulation Diameter 7.87mm (.310")  
 Wire Size AWG 10, 12  
 Wire Size mm² 3.09 - 5.01

**Material Info**

Old Part Number SC-230-56T

**Reference - Drawing Numbers**

Sales Drawing SD-19164-041

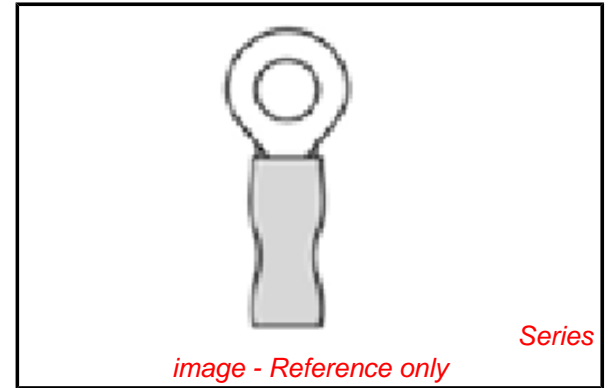

image - Reference only

**EU RoHS**

**ELV and RoHS Compliant**  
**REACH SVHC**  
 Not Reviewed  
**Halogen-Free Status**  
 Not Reviewed

**China RoHS**



**Need more information on product environmental compliance?**

Email [productcompliance@molex.com](mailto:productcompliance@molex.com)  
 For a multiple part number RoHS Certificate of Compliance, [click here](#)

Please visit the [Contact Us](#) section for any non-product compliance questions.

**Search Parts in this Series**

[19164Series](#)

**Application Tooling | [FAQ](#)**

*Tooling specifications and manuals are found by selecting the products below. Crimp Height Specifications are then contained in the Application Tooling Specification document.*

**Global**

Description	Product #
Power Crimp Tool Head for Prema-Seal™ Terminals 10-22 AWG	<a href="#">0640057400</a>
ATP Perishable Tool Kit Used in ATP Presses that Process Product on Tape	<a href="#">0198082025</a>
Hand Crimp Tool, UL Approved	<a href="#">0640017400</a>

**PLEASE CHECK [WWW.MOLEX.COM](http://WWW.MOLEX.COM) FOR LATEST PART INFORMATION**

MATERIAL NUMBER	ENGINEERING NUMBER	MATERIAL NUMBER ON TAPE	ENGINEERING NUMBER ON TAPE	STUD SIZE	"S" ±.005/0.03	"D" MAX	"H" ±.020/0.50	"L" MAX
191640060	SC-228-04	191640936	SC-228-04T	#4	.126/3.20	.39/9.9	1.469/11.91	1.39/35.1
191640061	SC-228-06	191640937	SC-228-06T	#6	.146/3.71	.39/9.9	1.469/11.91	1.39/35.1
191640062	SC-228-08	191640938	SC-228-08T	#8	.173/4.39	.39/9.9	1.469/11.91	1.39/35.1
191640063	SC-228-10	191640939	SC-228-10T	#10	.198/5.03	.39/9.9	1.469/11.91	1.39/35.1
191640065	SC-230-10	191640316	SC-230-10T	#10	.198/5.03	.54/13.7	1.302/7.67	1.55/39.4
191640066	SC-230-14	191640317	SC-230-14T	1/4	.265/6.73	.54/13.7	1.302/7.67	1.55/39.4
191640067	SC-230-56	191640318	SC-230-56T	5/16	.328/8.33	.54/13.7	1.302/7.67	1.55/39.4
191640068	SC-240-38	191640857	SC-240-38T	3/8	.390/9.91	.60/15.2	1.385/9.78	1.55/39.4
191640058	SC-201-12	---	---	1/2	.515/13.08	.76/19.3	---	1.87/47.5

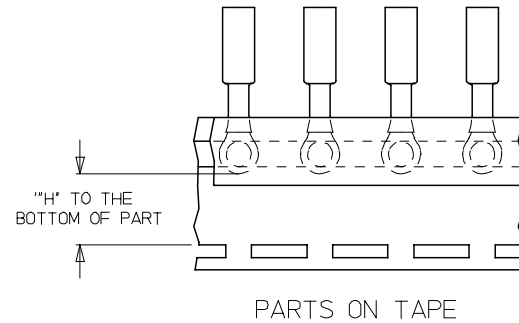
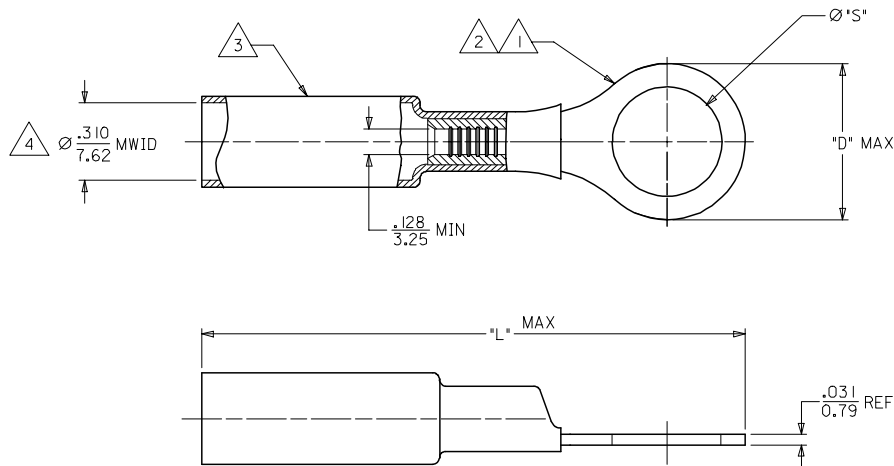

# SALES DRAWING

## NOTES:

- ①. TERMINAL MATERIAL: COPPER ALLOY
- ②. FINISH: ELECTRO TIN PLATE.
- ③. INSULATION MATERIAL: HEAT SHRINKABLE TUBING WITH HOTMELT ADHESIVE INNER LINER. COLOR: YELLOW
- ④. MWID = MAXIMUM WIRE INSULATION DIAMETER.
- ⑤. PARTS ON TAPE DOUBLE SPACED.

ADD MAT'L NUMBER EC NO: ETC2005-0208 DRW: JMW/RYCK 2005/05/31 CHK: D/ROROSS 2005/05/31 APPR: JPAN/LCK 2005/05/31	QUALITY SYMBOLS 	GENERAL TOLERANCES (UNLESS SPECIFIED)		DIMENSION STYLE IN/MM	SCALE ---	DESIGN UNITS INCH	THIRD ANGLE PROJECTION	
		4 PLACES ± ---	± ---	mm	INCH	DRAWN BY BENDERLE	DATE 2002/09/10	TITLE RING TONGUE TERMINAL PERMA-SEAL NIAC 12-10 AWG
		3 PLACES ± ---	± ---			CHECKED BY HBEITZEL	DATE 2002/09/10	MOLEX INCORPORATED
		2 PLACES ± ---	± ---			APPROVED BY RDEROSS	DATE 2002/09/10	
1 PLACE ± ---		± ---	± ---	ANGULAR ± ---°		MATERIAL NO.	DOCUMENT NO.	
DRAFT WHERE APPLICABLE MUST REMAIN WITHIN DIMENSIONS		SEE CHART		SD-19164-041		SHEET NO. 1 OF 1		