

## Features

- No External Components Except PIN Diode
- Supply-voltage Range: 4.5V to 5.5V
- Highest Sensitivity Due to Automatic Sensitivity Adaption (AGC) and Automatic Strong Signal Adaption (ATC)
- Highest Immunity Against Disturbances from Daylight and Lamps
- Available for Carrier Frequencies between 30 kHz to 76 kHz; Adjusted by Zener Diode Fusing
- TTL and CMOS Compatible
- Suitable Minimum Burst Length  $\geq 10$  Pulses/Burst

## Applications

- Home Entertainment Applications (Audio/Video)
- Home Appliances
- Remote Control Equipment

## 1. Description

The IC T2525 is a complete IR receiver for data communication that was developed and optimized for use in carrier-frequency-modulated transmission applications. The IC offers highest sensitivity as well as highest suppression of noise from daylight and lamps. The T2525 is available with broadest range of carrier frequencies (30, 33, 36, 37, 38, 40, 44, 56, 76 kHz) and 5 different noise suppression regulation types (standard, lamp, noise, short burst, data rate) covering requirements of high-end remote control solutions (please refer to selection guide available for T2525/ATA2526). The T2525 operates in a supply voltage range of 4.5V to 5.5V.

The function of T2525 can be described using the block diagram (see [Figure 1-1 on page 2](#)). The input stage meets two main functions. First, it provides a suitable bias voltage for the PIN diode. Secondly, the pulsed photo-current signals are transformed into a voltage by a special circuit which is optimized for low-noise applications. After amplification by a **Controlled Gain Amplifier (CGA)**, the signals have to pass a tuned integrated narrow bandpass filter with a center frequency  $f_0$  which is equivalent to the chosen carrier frequency of the input signal. The demodulator is used to convert the input burst signal into a digital envelope output pulse and to evaluate the signal information quality, i.e., unwanted pulses will be suppressed at the output pin. All this is done by means of an integrated dynamic feedback circuit which varies the gain as a function of the present environmental condition (ambient light, modulated lamps etc.). Other special features are used to adapt to the current application to secure best transmission quality.

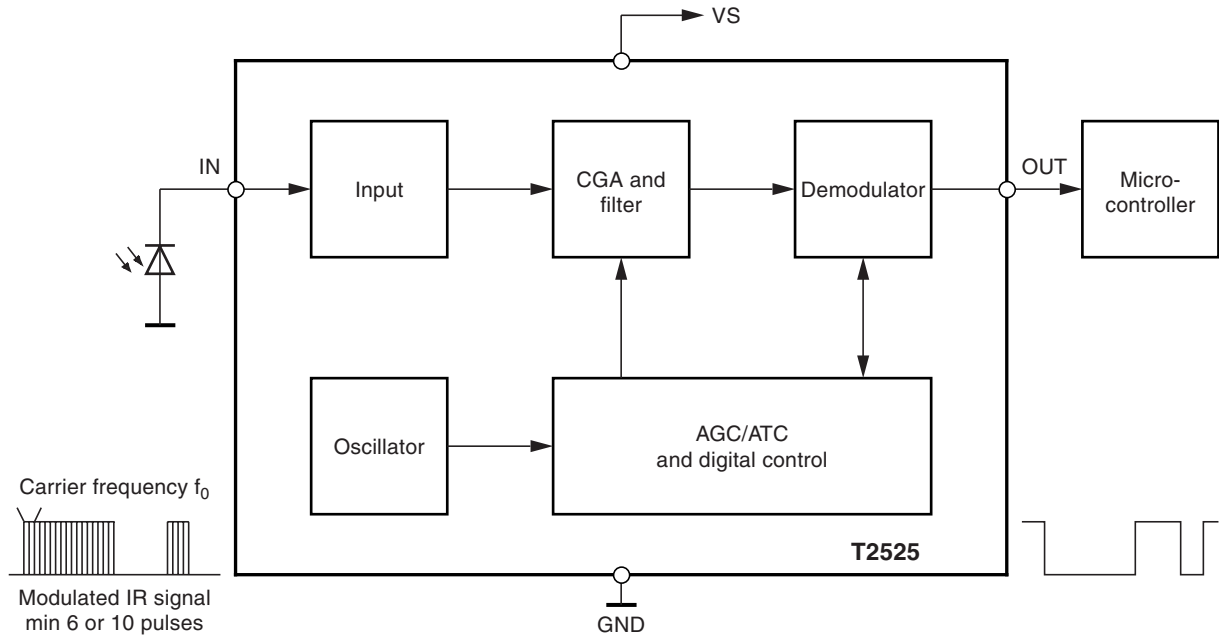


IR Receiver  
ASSP

T2525

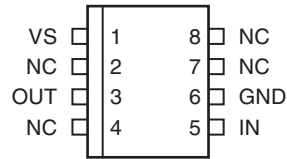


**Figure 1-1.** Block Diagram



## 2. Pin Configuration

**Figure 2-1.** Pinning SO8 and TSSOP8



**Table 2-1.** Pin Description

Pin	Symbol	Function
1	VS	Supply voltage
2	NC	Not connected
3	OUT	Data output
4	NC	Not connected
5	IN	Input PIN diode
6	GND	Ground
7	NC	Not connected
8	NC	Not connected

### 3. Absolute Maximum Ratings

Stresses beyond those listed under “Absolute Maximum Ratings” may cause permanent damage to the device. This is a stress rating only and functional operation of the device at these or any other conditions beyond those indicated in the operational sections of this specification is not implied. Exposure to absolute maximum rating conditions for extended periods may affect device reliability.

Parameters	Symbol	Value	Unit
Supply voltage	$V_S$	-0.3 to +6	V
Supply current	$I_S$	3	mA
Input voltage	$V_{IN}$	-0.3 to $V_S$	V
Input DC current at $V_S = 5V$	$I_{IN}$	0.75	mA
Output voltage	$V_O$	-0.3 to $V_S$	V
Output current	$I_O$	10	mA
Operating temperature	$T_{amb}$	-25 to +85	°C
Storage temperature	$T_{stg}$	-40 to +125	°C
Power dissipation at $T_{amb} = 25^\circ C$	$P_{tot}$	30	mW

### 4. Thermal Resistance

Parameter	Symbol	Value	Unit
Junction ambient SO8	$R_{thJA}$	130	K/W
Junction ambient TSSOP8	$R_{thJA}$	TBD	K/W

## 5. Electrical Characteristics

$T_{amb} = 25^{\circ}\text{C}$ ,  $V_S = 5\text{V}$  unless otherwise specified.

No.	Parameters	Test Conditions	Pin	Symbol	Min.	Typ.	Max.	Unit	Type*
<b>1</b>	<b>Supply</b>								
1.1	Supply-voltage range		1	$V_S$	4.5	5	5.5	V	C
1.2	Supply current	$I_{IN} = 0$	1	$I_S$	0.8	1.1	1.4	mA	B
<b>2</b>	<b>Output</b>								
2.1	Internal pull-up resistor <sup>(1)</sup>	$T_{amb} = 25^{\circ}\text{C}$ ; see <a href="#">Figure 6-7 on page 8</a>	1,3	$R_{PU}$		30/40		k $\Omega$	A
2.2	Output voltage low	$I_L = 2\text{ mA}$ ; see <a href="#">Figure 6-7 on page 8</a>	3,6	$V_{OL}$			250	mV	B
2.3	Output voltage high		3,1	$V_{OH}$	$V_S - 0.25$		$V_S$	V	B
2.4	Output current clamping	$R_2 = 0$ ; see <a href="#">Figure 6-7 on page 8</a>	3,6	$I_{OCL}$		8		mA	B
<b>3</b>	<b>Input</b>								
3.1	Input DC current	$V_{IN} = 0$ ; see <a href="#">Figure 6-7 on page 8</a>	5	$I_{IN\_DCMAX}$	-85			$\mu\text{A}$	C
3.2	Input DC current; <a href="#">Figure 6-2 on page 6</a>	$V_{IN} = 0$ ; $V_S = 5\text{V}$ , $T_{amb} = 25^{\circ}\text{C}$	5	$I_{IN\_DCMAX}$	-530	-960		$\mu\text{A}$	B
3.3	Minimum detection threshold current; <a href="#">Figure 6-1 on page 6</a>	Test signal: see <a href="#">Figure 6-6 on page 8</a> $V_S = 5\text{V}$ , $T_{amb} = 25^{\circ}\text{C}$ , $I_{IN\_DC} = 1\ \mu\text{A}$ ; square pp, burst $N = 16$ , $f = f_0$ ; $t_{PER} = 10\text{ ms}$ , <a href="#">Figure 6-6 on page 8</a> ; $\text{BER} = 50^{(2)}$	3	$I_{Eemin}$		-500		pA	B
3.4	Minimum detection threshold current with AC current disturbance $I_{IN\_AC100} = 3\ \mu\text{A}$ at 100 Hz	Test signal: see <a href="#">Figure 6-6 on page 8</a> $V_S = 5\text{V}$ , $T_{amb} = 25^{\circ}\text{C}$ , $I_{IN\_DC} = 1\ \mu\text{A}$ , square pp, burst $N = 16$ , $f = f_0$ ; $t_{PER} = 10\text{ ms}$ , <a href="#">Figure 6-6 on page 8</a> ; $\text{BER} = 50\%^{(2)}$	3	$I_{Eemin}$		-750		pA	C

\*) Type means: A =100% tested, B = 100% correlation tested, C = Characterized on samples, D = Design parameter

Notes: 1. Depending on version, see "Ordering Information"

2. BER = Bit Error Rate; e.g., BER = 5% means that with  $P = 20$  at the input pin 19...21 pulses can appear at the pin OUT

3. After transformation of input current into voltage

## 5. Electrical Characteristics (Continued)

$T_{amb} = 25^{\circ}\text{C}$ ,  $V_S = 5\text{V}$  unless otherwise specified.

No.	Parameters	Test Conditions	Pin	Symbol	Min.	Typ.	Max.	Unit	Type*
3.5	Maximum detection threshold current with $V_{IN} > 0\text{V}$	Test signal: see <a href="#">Figure 6-6 on page 8</a> $V_S = 5\text{V}$ , $T_{amb} = 25^{\circ}\text{C}$ , $I_{IN\_DC} = 1\ \mu\text{A}$ ; square pp, burst $N = 16$ , $f = f_0$ ; $t_{PER} = 10\text{ms}$ , <a href="#">Figure 6-6 on page 8</a> ; $\text{BER} = 5\%^{(2)}$	3	$I_{Eemax}$	-400			$\mu\text{A}$	D
<b>4</b>	<b>Controlled Amplifier and Filter</b>								
4.1	Maximum value of variable gain (CGA)			$G_{VARMAX}$		51		dB	D
4.2	Minimum value of variable gain (CGA)			$G_{VARMIN}$		-5		dB	D
4.3	Total internal amplification <sup>(3)</sup>			$G_{MAX}$		71		dB	D
4.4	Center frequency fusing accuracy of bandpass	$V_S = 5\text{V}$ , $T_{amb} = 25^{\circ}\text{C}$		$f_{0\_FUSE}$	-3	$f_0$	+3	%	A
4.5	Overall accuracy center frequency of bandpass			$f_0$	-6.7	$f_0$	+4.1	%	C
4.6	BPF bandwidth: type N0 - N3	-3 dB; $f_0 = 38\text{kHz}$ ; see <a href="#">Figure 6-4 on page 7</a>		B		3.5		kHz	C
	BPF bandwidth: type N6, N7	-3 dB; $f_0 = 38\text{kHz}$ ; <a href="#">Figure 6-4 on page 7</a>		B		5.4		kHz	C

\*) Type means: A = 100% tested, B = 100% correlation tested, C = Characterized on samples, D = Design parameter

Notes: 1. Depending on version, see "Ordering Information"

2. BER = Bit Error Rate; e.g., BER = 5% means that with  $P = 20$  at the input pin 19...21 pulses can appear at the pin OUT

3. After transformation of input current into voltage

### 5.1 ESD

All pins  $\Rightarrow$  2000V HBM; 200V MM, MIL-STD-883C, Method 3015.7

### 5.2 Reliability

Electrical qualification (1000h) in molded SO8 plastic package

## 6. Typical Electrical Curves at $T_{amb} = 25^{\circ}\text{C}$

Figure 6-1.  $I_{Emin}$  versus  $I_{IN\_DC}$ ,  $V_S = 5V$

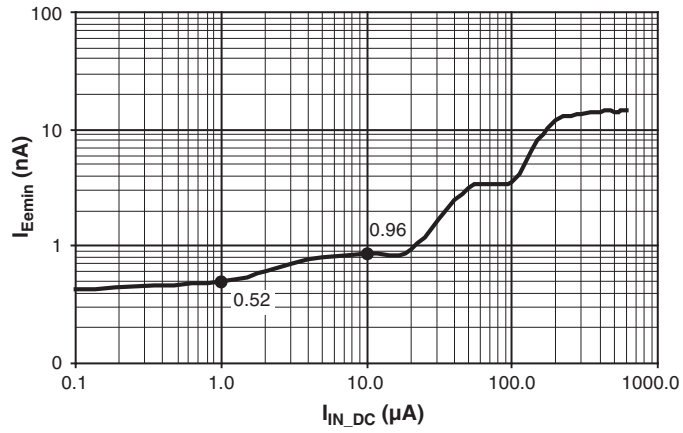


Figure 6-2.  $V_{IN}$  versus  $I_{IN\_DC}$ ,  $V_S = 5V$

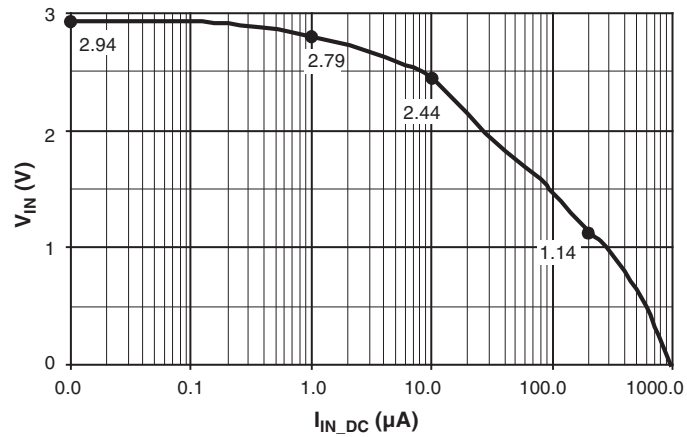


Figure 6-3. Data Transmission Rate,  $V_S = 5V$

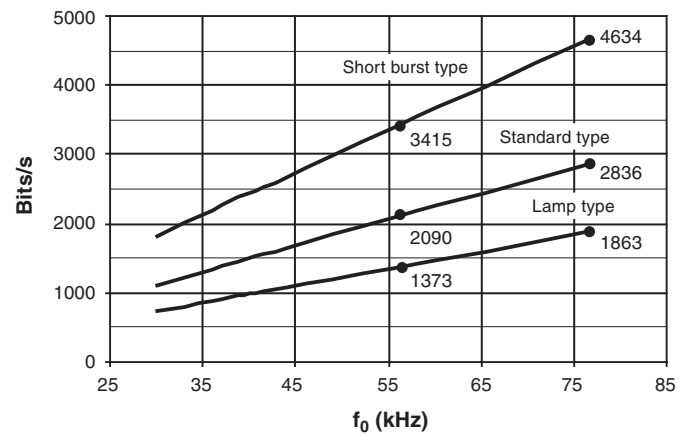
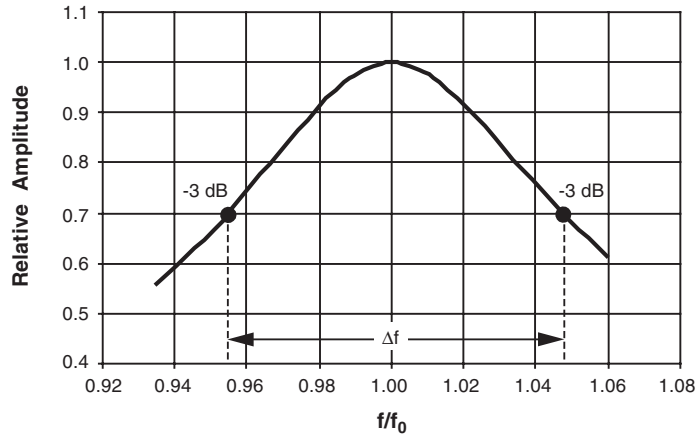
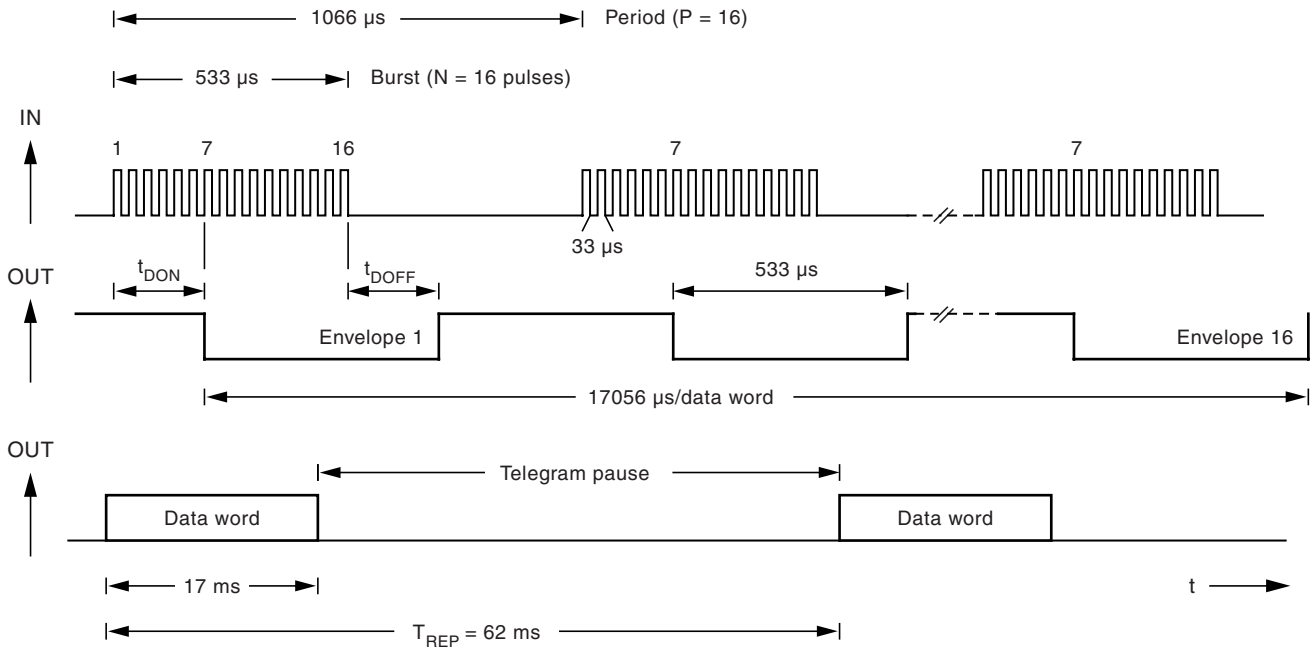


Figure 6-4. Typical Bandpass Curve



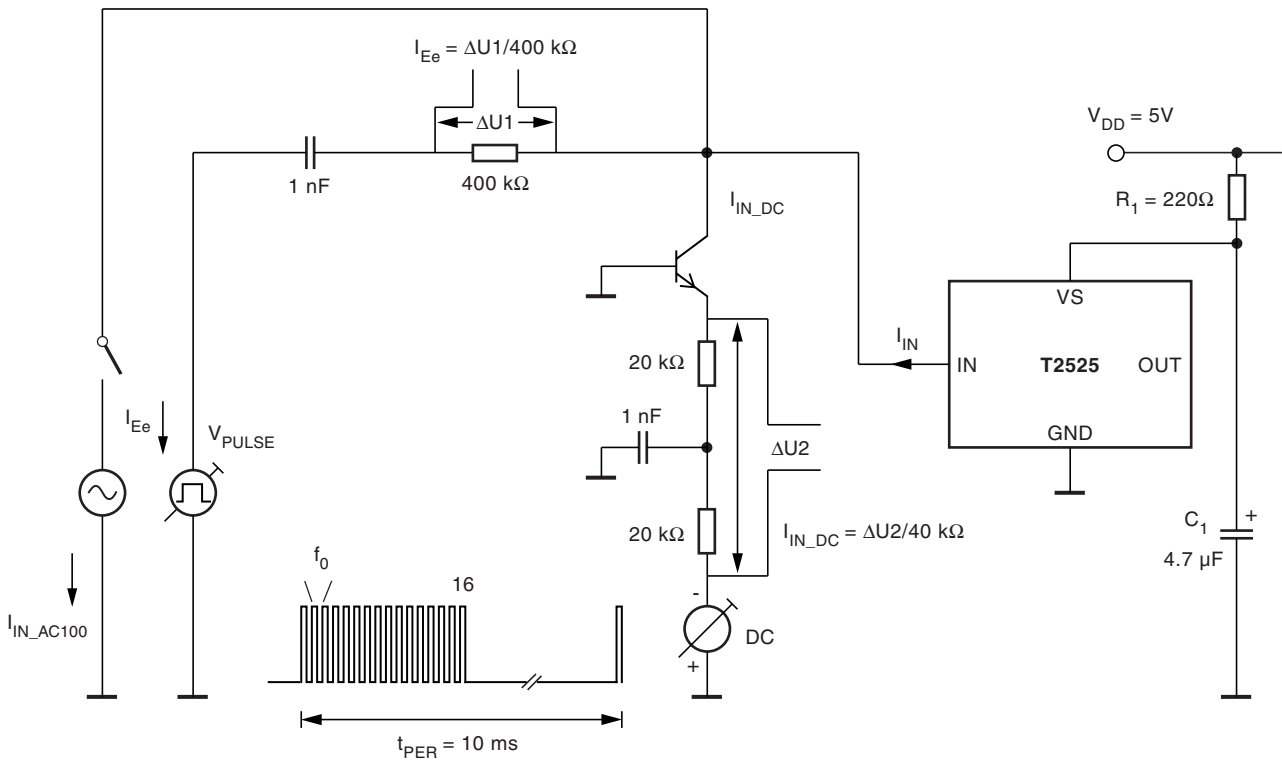
$Q = f_0/\Delta f$ ;  $\Delta f = -3 \text{ dB values}$ . Example:  $Q = 1/(1.047 - 0.954) = 11$

Figure 6-5. Illustration of Used Terms

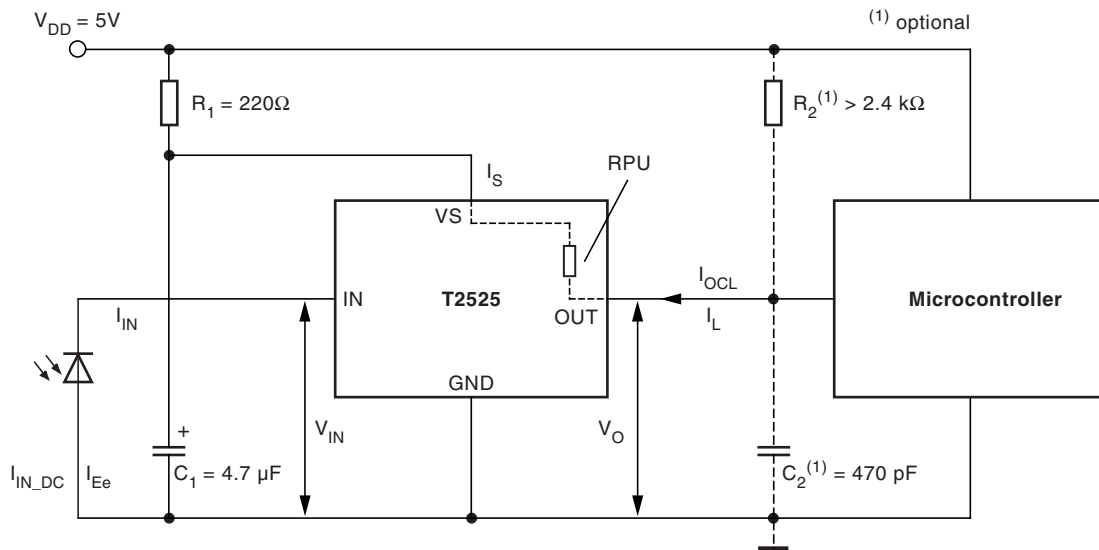


Example:  $f = 30 \text{ kHz}$ , burst with 16 pulses, 16 periods

**Figure 6-6. Test Circuit**



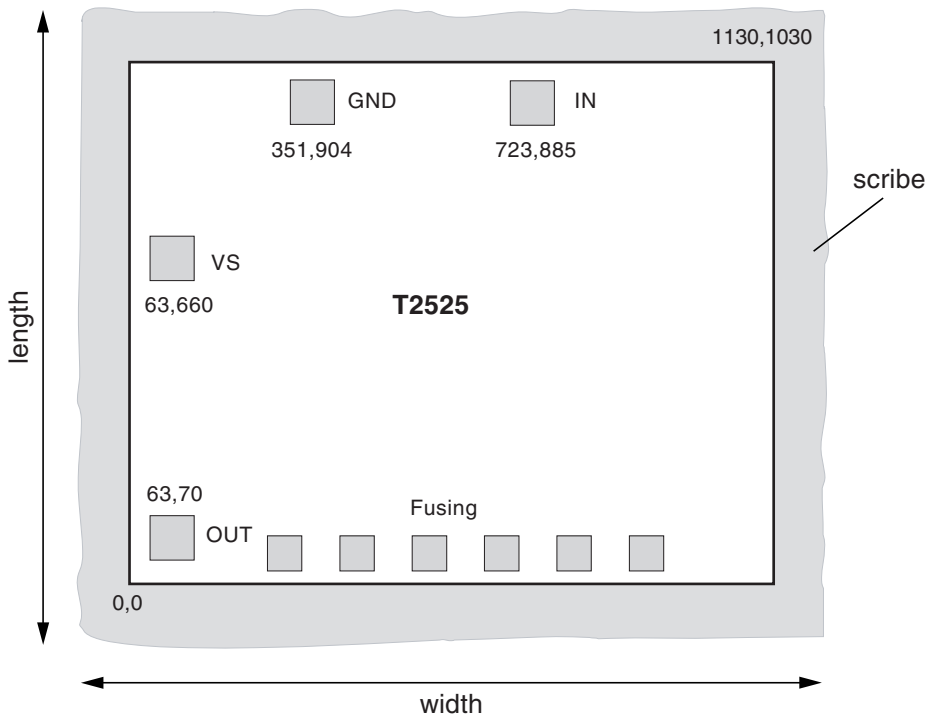
**Figure 6-7. Application Circuit**





## 7. Chip Dimensions

Figure 7-1. Chip Size in  $\mu\text{m}$



Note: Pad coordinates are for lower left corner of the pad in  $\mu\text{m}$  from the origin 0,0

<b>Dimensions</b>	Length inclusive scribe	1.15 mm
	Width inclusive scribe	1.29 mm
	Thickness	$290\mu \pm 5\%$
<b>Pad metallurgy</b>	Pads	$90\mu \times 90\mu$
	Fusing pads	$70\mu \times 70\mu$
	Material	AlCu/AlSiTi <sup>(1)</sup>
<b>Finish</b>	Thickness	0.8 $\mu\text{m}$
	Material	Si <sub>3</sub> N <sub>4</sub> /SiO <sub>2</sub>
	Thickness	0.7/0.3 $\mu\text{m}$

Note: Value depends on manufacture location.

## 8. Ordering Information

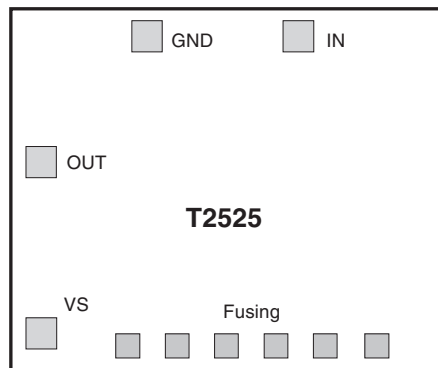
Delivering: unsawn wafers (DDW) in box.

Extended Type Number	PL <sup>(2)</sup>	R <sub>PU</sub> <sup>(3)</sup>	D <sup>(4)</sup>	Type <sup>(5)</sup>
T2525N0xx <sup>(1)</sup> -DDW	2	30	2090	<b>Standard type:</b> ≥ 10 pulses, enhanced sensibility, high data rate
T2525N1xx <sup>(1)</sup> -DDW	1	30	2090	<b>Standard type:</b> ≥ 10 pulses, enhanced sensibility, high data rate
T2525N2xx <sup>(1)</sup> -DDW	2	40	1373	<b>Lamp type:</b> ≥ 10 pulses, enhanced suppression of disturbances, secure data transmission
T2525N3xx <sup>(1)</sup> -DDW	1	40	1373	<b>Lamp type:</b> ≥ 10 pulses, enhanced suppression of disturbances, secure data transmission
T2525N6xx <sup>(1)</sup> -DDW	2	30	3415	<b>Short burst type:</b> ≥ 6 pulses, enhanced data rate
T2525N7xx <sup>(1)</sup> -DDW	1	30	3415	<b>Short burst type:</b> ≥ 6 pulses, enhanced data rate

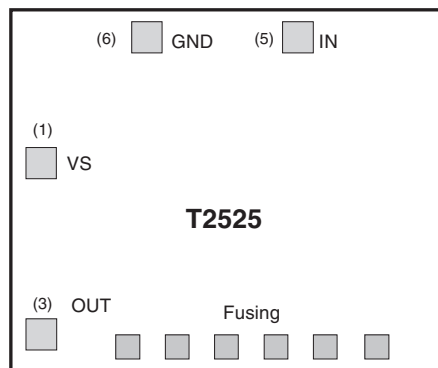
- Notes:
- xx means the used carrier frequency value  $f_0$  30, 33, 36, 38, 40, 44, 56 kHz. (76 kHz type on request)
  - Two pad layout versions (see [Figure 9-1](#) and [Figure 9-2](#)) available for different assembly demand
  - Integrated pull-up resistor at pin OUT (see “Electrical Characteristics”)
  - Typical data transmission rate up to bit/s with  $f_0 = 56$  kHz,  $V_S = 5$ V (see [Figure 6-3 on page 6](#))
  - On request: noise type, data rate type

## 9. Pad Layout

**Figure 9-1.** Pad Layout 1



**Figure 9-2.** Pad Layout 2



## 10. Revision History

Please note that the following page numbers referred to in this section refer to the specific revision mentioned, not to this document.

Revision No.	History
4657F-AUTO-10/06	<ul style="list-style-type: none"><li>• Features on page 1 changed</li><li>• Applications on page 1 changed</li><li>• Section 1 "Description" on page 1 changed</li><li>• Section 5 "Electrical Characteristics" number 3.3 and 3.4 on page 4 changed</li><li>• Section 8 "Ordering Information" on page 10 changed</li><li>• Section 9 "Pad Layout" on page 10 changed</li></ul>
4657E-AUTO-04/06	<ul style="list-style-type: none"><li>• Put datasheet in a new template</li><li>• Section 8 "Ordering Information" on page 10 changed</li></ul>



## Atmel Corporation

2325 Orchard Parkway  
San Jose, CA 95131, USA  
Tel: 1(408) 441-0311  
Fax: 1(408) 487-2600

## Regional Headquarters

### Europe

Atmel Sarl  
Route des Arsenaux 41  
Case Postale 80  
CH-1705 Fribourg  
Switzerland  
Tel: (41) 26-426-5555  
Fax: (41) 26-426-5500

### Asia

Room 1219  
Chinachem Golden Plaza  
77 Mody Road Tsimshatsui  
East Kowloon  
Hong Kong  
Tel: (852) 2721-9778  
Fax: (852) 2722-1369

### Japan

9F, Tonetsu Shinkawa Bldg.  
1-24-8 Shinkawa  
Chuo-ku, Tokyo 104-0033  
Japan  
Tel: (81) 3-3523-3551  
Fax: (81) 3-3523-7581

## Atmel Operations

### Memory

2325 Orchard Parkway  
San Jose, CA 95131, USA  
Tel: 1(408) 441-0311  
Fax: 1(408) 436-4314

### Microcontrollers

2325 Orchard Parkway  
San Jose, CA 95131, USA  
Tel: 1(408) 441-0311  
Fax: 1(408) 436-4314

La Chantrerie  
BP 70602  
44306 Nantes Cedex 3, France  
Tel: (33) 2-40-18-18-18  
Fax: (33) 2-40-18-19-60

### ASIC/ASSP/Smart Cards

Zone Industrielle  
13106 Rousset Cedex, France  
Tel: (33) 4-42-53-60-00  
Fax: (33) 4-42-53-60-01

1150 East Cheyenne Mtn. Blvd.  
Colorado Springs, CO 80906, USA  
Tel: 1(719) 576-3300  
Fax: 1(719) 540-1759

Scottish Enterprise Technology Park  
Maxwell Building  
East Kilbride G75 0QR, Scotland  
Tel: (44) 1355-803-000  
Fax: (44) 1355-242-743

### RF/Automotive

Theresienstrasse 2  
Postfach 3535  
74025 Heilbronn, Germany  
Tel: (49) 71-31-67-0  
Fax: (49) 71-31-67-2340

1150 East Cheyenne Mtn. Blvd.  
Colorado Springs, CO 80906, USA  
Tel: 1(719) 576-3300  
Fax: 1(719) 540-1759

### Biometrics/Imaging/Hi-Rel MPU/ High-Speed Converters/RF Datacom

Avenue de Rochepleine  
BP 123  
38521 Saint-Egreve Cedex, France  
Tel: (33) 4-76-58-30-00  
Fax: (33) 4-76-58-34-80

---

## Literature Requests

[www.atmel.com/literature](http://www.atmel.com/literature)

**Disclaimer:** The information in this document is provided in connection with Atmel products. No license, express or implied, by estoppel or otherwise, to any intellectual property right is granted by this document or in connection with the sale of Atmel products. **EXCEPT AS SET FORTH IN ATMEL'S TERMS AND CONDITIONS OF SALE LOCATED ON ATMEL'S WEB SITE, ATMEL ASSUMES NO LIABILITY WHATSOEVER AND DISCLAIMS ANY EXPRESS, IMPLIED OR STATUTORY WARRANTY RELATING TO ITS PRODUCTS INCLUDING, BUT NOT LIMITED TO, THE IMPLIED WARRANTY OF MERCHANTABILITY, FITNESS FOR A PARTICULAR PURPOSE, OR NON-INFRINGEMENT. IN NO EVENT SHALL ATMEL BE LIABLE FOR ANY DIRECT, INDIRECT, CONSEQUENTIAL, PUNITIVE, SPECIAL OR INCIDENTAL DAMAGES (INCLUDING, WITHOUT LIMITATION, DAMAGES FOR LOSS OF PROFITS, BUSINESS INTERRUPTION, OR LOSS OF INFORMATION) ARISING OUT OF THE USE OR INABILITY TO USE THIS DOCUMENT, EVEN IF ATMEL HAS BEEN ADVISED OF THE POSSIBILITY OF SUCH DAMAGES.** Atmel makes no representations or warranties with respect to the accuracy or completeness of the contents of this document and reserves the right to make changes to specifications and product descriptions at any time without notice. Atmel does not make any commitment to update the information contained herein. Unless specifically provided otherwise, Atmel products are not suitable for, and shall not be used in, automotive applications. Atmel's products are not intended, authorized, or warranted for use as components in applications intended to support or sustain life.

© 2006, Atmel Corporation. All rights reserved. Atmel®, logo and combinations thereof, Everywhere You Are® and others are registered trademarks or trademarks of Atmel Corporation or its subsidiaries. Other terms and product names may be trademarks of others.