

UNIVERSAL ISM BAND FSK TRANSCEIVER MODULE

WITH 500mW OUTPUT POWER

RFM12BP

(the purpose of this spec covers mainly for the physical characteristic of the module, for register configure and its related command info please refer to [RF12B datasheet](#))

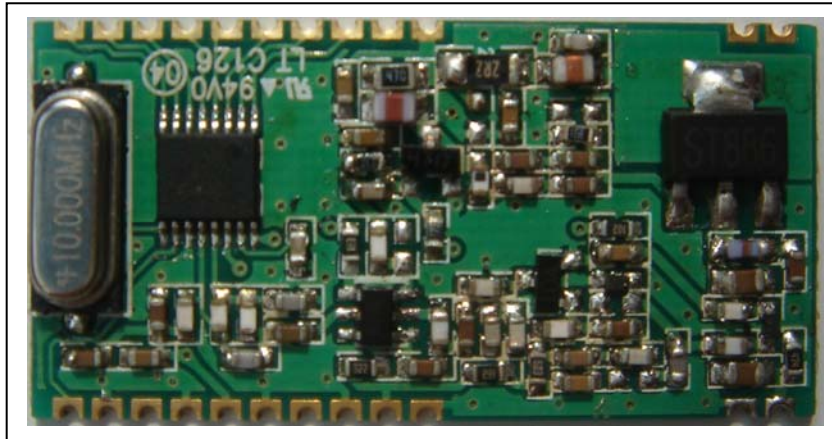

General Introduction

RFM12BP is a low costing ISM band transceiver module implemented with 500mW output power. It works signal ranges from 433/868/915MHZ bands, The SPI interface is used to communicate with microcontroller for parameter setting.

Features:

- High output power with 500mW
- High input sensitivity with -117dBm
- Low costing, high performance and price ratio
- PLL and zero IF technology
- Fast PLL lock time
- High resolution PLL with 2.5 KHz step
- High data rate (up to 115.2 kbps with internal demodulator, with external RC filter highest data rate is 256 kbps)
- 50 OHM antenna input/output
- Programmable TX power
- Programmable TX frequency deviation (from 15 to 240 KHz)
- Programmable receiver bandwidth (from 67 to 400 kHz)
- Analog and digital signal strength indicator (ARSSI/DRSSI)
- Automatic frequency control (AFC)
- Data quality detection (DQD)
- Internal data filtering and clock recovery
- RX synchron pattern recognition
- SPI compatible serial control interface
- Clock and reset signal output for external MCU use
- 16 bit RX Data FIFO
- Two 8 bit TX data registers
- Wakeup timer
- 2.2V – 3.8V power supply for FSK IC, 12V power supply for power amplifier
- Standby current less than 0.3uA
- Supports very short packets (down to 3 bytes)

Typical Application:

- Remote control
- Remote sensor
- Wireless data collection
- Home security system
- Toys

Pin Definition:

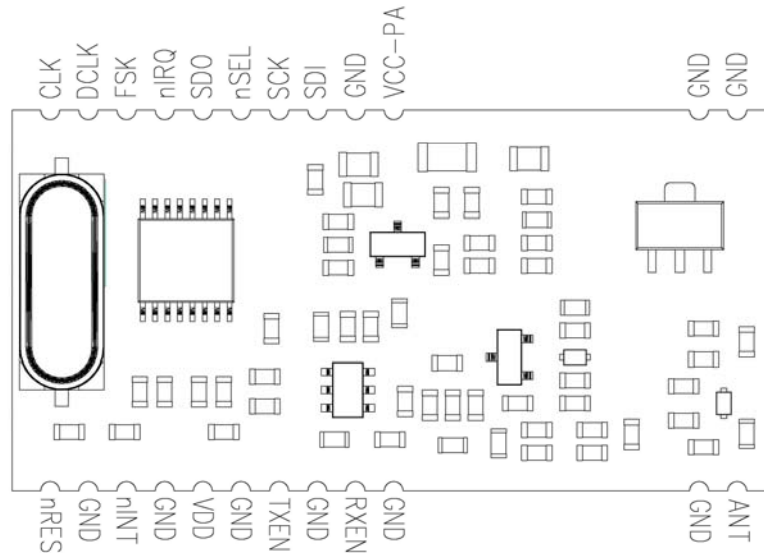

PIN number	definition	Type	Function
1	GND	S	ground
2	GND	S	ground
3	VCC-PA	S	Positive power supply for power amplifier (12V)
4	GND	S	ground
5	SDI	DI	SPI data input
6	SCK	DI	SPI clock input
7	nSEL	DI	Chip select (active low)
8	SDO	DO	Serial data output with bus hold
9	nIRQ	DO	Interrupts request output (active low)
10	FSK/DATA/n FFS	DI/DO/DI	Transmit FSK data input/ Received data output (FIFO not used)/ FIFO select
11	DCLK/CFIL/F FIT	DO/AIO/DO	Clock output (no FIFO)/ external filter capacitor(analog mode)/ FIFO interrupts(active high)when FIFO level set to 1, FIFO empty interruption can be achieved
12	CLK	DO	Clock output for external microcontroller
13	nRES	DIO	Reset output (active low)
14	GND	S	ground
15	nINT/VDI	DI/ DO	Interrupt input (active low)/Valid data indicator
16	GND	S	ground
17	VDD	S	Positive power supply for FSK IC(2.2V-3.8V)
18	GND	S	ground

19	TXEN	AI	TX enable (active high), Drive current $\geq 3\text{mA}$. TX disable(active low).
20	GND	S	ground
21	RXEN	AI	RX enable (active high), Drive current $\geq 3\text{mA}$. RX disable(active low).
22	GND	S	ground
23	GND	S	ground
24	ANT	AIO	RF signal output/input (50 OHM)

Typical Application

Typical application with FIFO usage

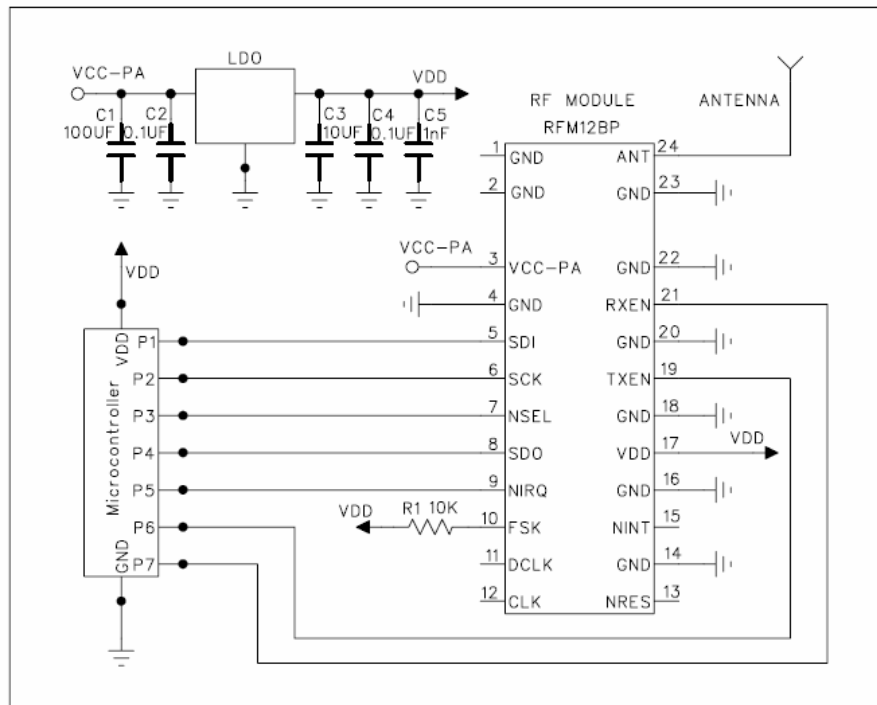

Electrical Parameter:

Maximum (not at working mode)

symbol	parameter	minimum	maximum	Unit
VDD	Positive power supply for FSK IC	-0.5	4.0	V
VCC-PA	Positive power supply for power amplifier	-0.5	13	V
V _{in}	All pin input level except VDD,VCC-PA,GND,ANT	-0.5	VDD+0.5	V
I _{in}	Input current except VDD,VCC-PA,GND,ANT	-25	25	mA
ESD	Human body model		1000	V
T _{st}	Storage temperature	-55	125	°C
T _{ld}	Soldering temperature(10s)		260	°C

Recommended working range

symbol	parameter	min	max	Unit
VDD	Positive power supply	2.2	3.8	V
VCC-PA	Positive power supply for power amplifier	11	13	V
T _{op}	Working temperature	-40	85	°C

DC characteristic

symbol	parameter	Remark	min	typ	max	Unit
I _{dd_TX_PMA} x	Supply current (TX mode, P _{out} = 500mW)	433MHz band 868/915MHz band		200 230		mA
I _{dd_RX}	Supply current (RX mode)	433MHz band 868/915MHz band		20 23		mA
I _x	Idle current	Crystal oscillator on		0.62	1.2	mA
I _{pd}	Sleep mode current	All blocks off		0.3		uA
I _{lb}	Low battery detection			0.5		uA
V _{lb}	Low battery detect threshold	0.1V per step	2.2		3.8	V
V _{lba}	Low battery detection accuracy		0		5	%
V _{il}	Low level input				0.3*V _{dd}	V
V _{ih}	High level input		0.7*V _{dd}			V
I _{il}	Leakage current	V _{il} =0V	-1		1	uA
I _{ih}	Leakage current	V _{ih} =V _{dd} , V _{dd} =4V	-1		1	uA
V _{ol}	Low level output	I _{ol} =2mA			0.4	V
V _{oh}	High level output	I _{oh} =-2mA	V _{dd} -0.4			V

AC characteristic

symbol	parameter	remark	min	typica l	max	Unit
f _{ref}	PLL frequency		9	10	11	MHz
f _{LO}	frequency (10MHz crystal used)	433 MHz band,2.5KHz step 868 MHz band,5KHz step 915 MHz band,7.5KHz step	430.24 860.48 900.72		439.75 879.51 929.27	MHz
f _{LO}	frequency (9MHz crystal used)	433 MHz band,2.5KHz step 868 MHz band,5KHz step 915 MHz band,7.5KHz step	387.22 774.43 810.65		395.76 791.56 836.34	MHz
f _{LO}	frequency (11MHz crystal used)	433 MHz band,2.5KHz step 868 MHz band,5KHz step 915 MHz band,7.5KHz step	473.26 946.53 990.79		483.73 967.46 1022.2	MHz
BW	Receiver bandwidth	mode 0 mode 1 mode 2	60 120 180	67 134 200	75 150 225	KHz

		mode 3	240	270	300	
		mode 4	300	350	375	
		mode 5	360	400	450	
t _{lock}	PLL lock time	After 10MHz step hopping, frequency error <10 kHz		30		us
t _{st, P}	PLL startup time	With a running crystal oscillator		200	300	us
BR	Data rate	With internal digital demodulator	0.6		115.2	kbps
BR _A	Data rate	With external RC filter			256	kbps
P _{min}	Sensitivity (BER 10 ⁻³ , BW=134KHz, BR=1 .2kbps,)	433MHz band 868MHz band 915MHz band		-118 -114 -112	-116 -112 -110	dBm
AFC _{range}	AFC working range	df _{FSK} : FSK deviation in the received signal		0.8* df _{FSK}		

AC characteristic(Transmitter)

symbol	parameter	remark	min	typical	max	Unit
P _{max_50}	Max. output power delivered to 50Ohm load	433MHZ band 868MHZ band 915MHZ band	26 25 25	27 27 27		dBm
BR _{TX}	FSK bit rate	Via internal TX data register			172	kbps
BRA _{TX}	FSK bit rate	TX data connected to the FSK input			256	kbps
df _{fsk}	FSK frequency deviation	Programmable in 15 kHz steps	15		240	KHZ

AC characteristic(Turn-on/Turnaround timings)

symbol	parameter	remark	min	typical	max	Unit
T _{st}	Crystal oscillator startup time	Crystal ESR < 100		1	5	ms
T _{tx_XTAL_ON}	Transmitter turn-on time	Synthesizer off, crystal oscillator on with 10 MHz step		250		us
T _{rx_XTAL_ON}	Receiver turn-on time	Synthesizer off, crystal oscillator on with 10 MHz step		250		us
T _{tx_rx_SYNT_ON}	Transmitter – Receiver turnover time	Synthesizer and crystal oscillator on during TX/RX change with 10 MHz step		150		us

$T_{rx_tx_SYNT_ON}$	Receiver – Transmitter turnover time	Synthesizer and crystal oscillator on during RX/TX change with 10 MHz step		150		us
C_{xl}	Crystal load capacitance	Programmable in 0.5 pF steps, tolerance+/- 10%	8.5		16	pf
t_{POR}	Internal POR timeout	After V_{dd} has reached 90% of final value			100	ms
t_{PBt}	Wake-up timer clock period	Calibrated every 30 seconds	0.96		1.05	ms
$C_{in, D}$	Digital input capacitance				2	pf
$t_{r, f}$	Digital output rise/fall time	15pF pure capacitive load			10	ns

Mechanical Dimension

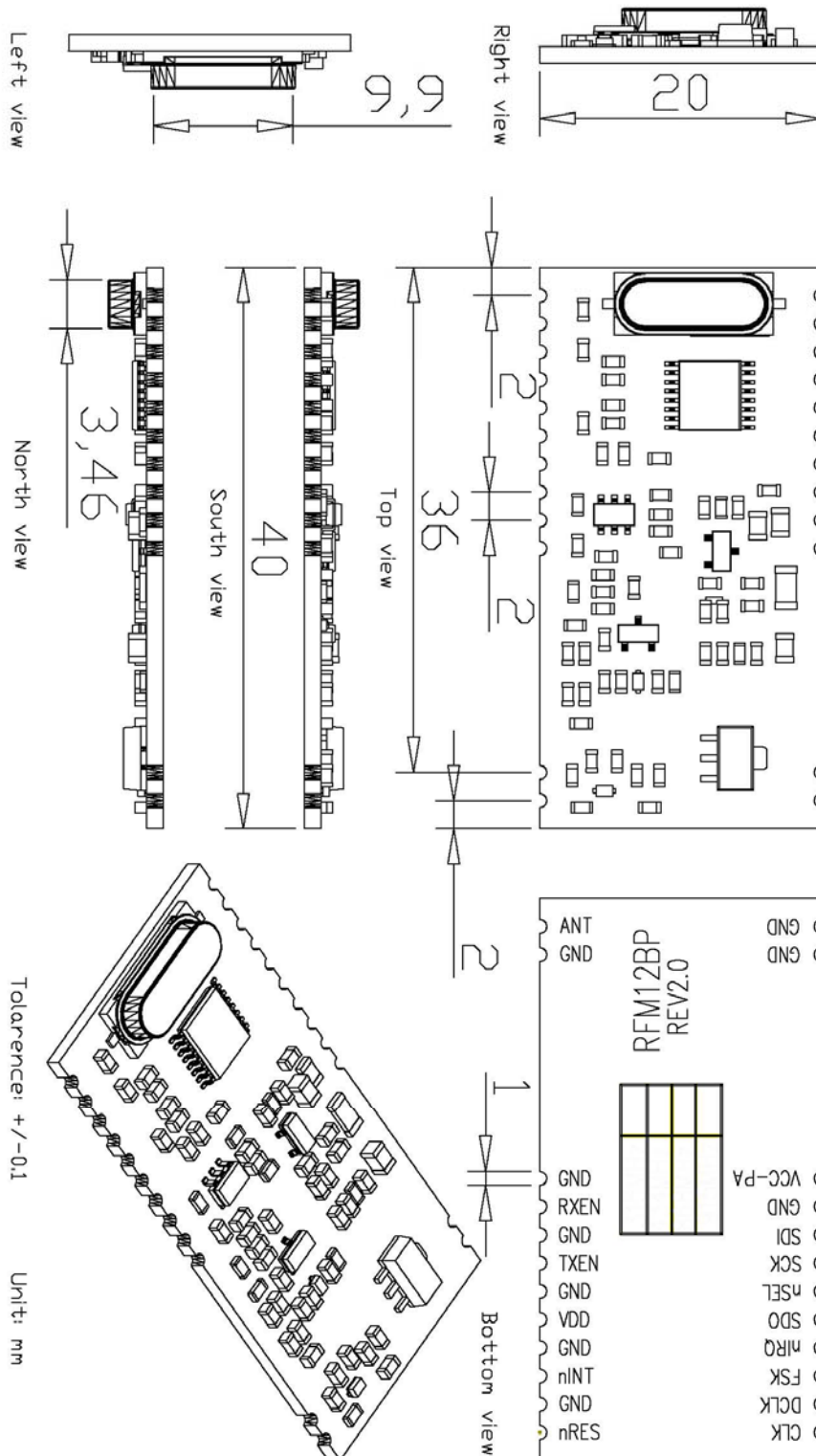

Module Model Definition

model=module-operation band

RFM12BP – 433

module type

operation band

- example: 1, RFM12BP module at 433MHz band, RFM12BP-433.
2, RFM12BP module at 868MHZ band, RFM12BP-868.

<p>HOPE MICROELECTRONICS CO.,LTD Rm B.8/F LiJingGe Emperor Regency 6012 ShenNan Rd., Shenzhen,China Tel: 86-755-82973805 Fax: 86-755-82973550 Email: sales@hoperf.com trade@hoperf.com Website: http://www.hoperf.com http://www.hoperf.cn http://hoperf.en.alibaba.com</p>	<p>This document may contain preliminary information and is subject to change by Hope Microelectronics without notice. Hope Microelectronics assumes no responsibility or liability for any use of the information contained herein. Nothing in this document shall operate as an express or implied license or indemnity under the intellectual property rights of Hope Microelectronics or third parties. The products described in this document are not intended for use in implantation or other direct life support applications where malfunction may result in the direct physical harm or injury to persons. NO WARRANTIES OF ANY KIND, INCLUDING, BUT NOT LIMITED TO, THE IMPLIED WARRANTIES OF MECHANABILITY OR FITNESS FOR A PARTICULAR PURPOSE, ARE OFFERED IN THIS DOCUMENT.</p> <p>©2006, HOPE MICROELECTRONICS CO.,LTD. All rights reserved.</p>
--	--