

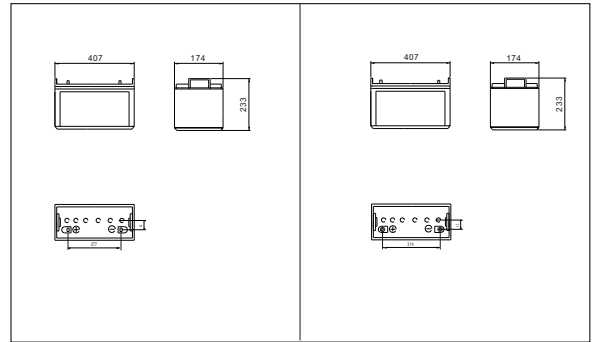

SW121200(12V120AH)



Outer dimensions (mm)



Specifications

Nominal Voltage		12V
Rated capacity (10 hour rate)		120 Ah
Dimensions	Total Height	233 mm (9.17 inches)
	Height	209 mm (8.23 inches)
	Length	407 mm (16.0 inches)
	Width	174mm (6.85inches)
Weight Approx		38 Kg (83.98 lbs)

Terminal Type (mm)

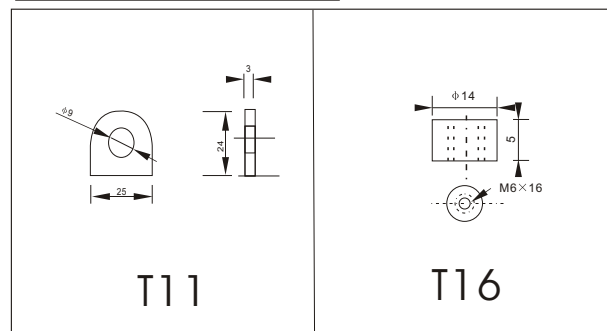

Characteristics

Capacity 25°C(77°F)	10 hour rate(12.0A)	120 AH
	5 hour rate(19.2A)	96 AH
	1 hour rate(72.0A)	72 AH
Internal Resistance	Full charged Battery at 25°C(77°F)	2.8 mΩ
Capacity affected by Temperature (10hour rate)	40°C(104°F)	102%
	25°C(77°F)	100%
	0°C(32°F)	85%
	-15°C(5°F)	65%
Self-Discharge at 25°C(77°F)	Capacity after 3 month storage	91%
	Capacity after 6 month storage	82%
	Capacity after 12 month storage	64%
Terminal		T11, T16
Charge (constant Voltage)	Cycle	Initial Charging Current less than 48 A Voltage 14.10-14.40V
	Float	Voltage 13.50-13.80V

Discharge Curves 25°C(77°F)

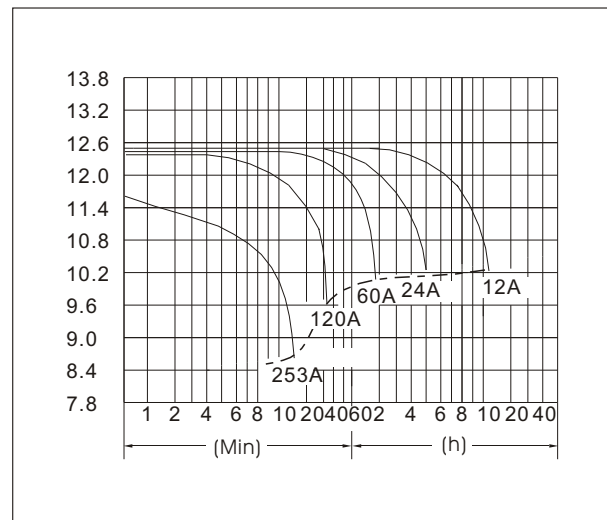

Constant Current(Amp) and Constant Power(Watt) Discharge Table at 25°C(77°F)

Time		5min	10min	15min	30min	1h	2h	3h	4h	5h	8h	10h	20h
960V	A	384	253	204	137	72	42	31	24.0	19.8	14.0	12.6	6.8
	W	3967	2704	2189	1471	778	461	343	270.0	225.1	160.9	145.5	79.1
1020V	A	372	228	192	131	68	40	30	23.4	19.4	13.7	12.4	6.6
	W	3976	2551	2151	1468	765	462	347	272.1	226.6	160.1	145.2	77.4
1050V	A	360	204	168	122	66	39	29	23.0	19.2	13.6	12.1	6.6
	W	3933	2325	1919	1409	759	454	341	269.6	225.1	159.5	143.4	78.0
1080V	A	347	193	156	113	63	38	29	22.7	18.7	13.2	12.0	6.5
	W	3894	2221	1800	1307	738	447	337	267.8	221.3	156.4	142.6	77.2
11.10V	A	335	180	144	101	61	37	28	22.1	18.2	12.8	11.4	6.1
	W	3803	2090	1679	1179	720	440	328	263.0	217.7	153.8	137.6	74.2