

**GBM-9000FG (RoHS Compliant)**  
**5V / 850 nm / 2.125 Gb/s Multi-Mode Gigabit Interface Converter (GBIC)**

**FEATURES**

- | Up to 2.5 Gbps Bi-directional Data Links
- | Compliant with 1X / 2X Fibre Channel FC-PI 13.0
- | Compliant with Gigabit Interface Converter (GBIC) Specification Rev. 5.5
- | 850 nm VCSEL Laser Transmitter
- | Hot Pluggable module with Duplex SC Connector
- | Multi-rate Operation for 2.5 / 2.125 / 1.062 / 1.25 Gbps
- | Link Distance at 2.125 Gbd  
150 m links with 62.5/125 µm MMF Cables  
300 m links with 50/125 µm MMF Cables
- | Link Distance at 1.026 Gbd  
300 m links with 62.5/125 µm MMF Cables  
550 m links with 50/125 µm MMF Cables
- | SCA-2 Host Connector
- | Single +5 V Power Supply
- | RoHS Compliant
- | Differential PECL Inputs and Outputs
- | TTL RX-LOS Output
- | Class 1 Laser International Safety Standard IEC-60825 Compliant

**DESCRIPTION**

The GBM-9000FG series optical transceivers meet the Gigabit Interface Converter (GBIC) specification Rev. 5.5. It satisfies the optical interface specifications defined in IEEE 802.3z Drift 5.0 1000 BASE-SX for Gigabit Ethernet and 1x / 2x Fibre Channel FC-PI 13.0. This module is designed for multi-mode fiber and operates at a nominal wavelength of 850 nm. The transmitter section uses a multiple quantum well VCSEL and is a class 1 laser compliant according to International Safety Standard IEC-60825. The receiver section uses an integrated GaAs detector preamplifier (IDP) mounted in an optical header and a limiting post-amplifier IC. A PECL input / output logic interface is used. TTL RX-LOS output simplifies interface to external circuitry. A 20-pin SCA-2 host connector is used to connect the converter to the host system.

**LASER SAFETY**

This single mode transceiver is a Class 1 laser product. It complies with IEC-60825 and FDA 21 CFR 1040.10 and 1040.11. The transceiver must be operated within the specified temperature and voltage limits. The optical ports of the module shall be terminated with an optical connector or with a dust plug.

**APPLICATIONS**

- | Switch to Switch Interface
- | High Speed Interface for File Servers
- | Data Storage
- | Dual Rate 1.06 / 2.125 Gb/s Fibre Channel

**ORDER INFORMATION**

P/No.	Bit Rate (Gb/s)	FC-PI	Distance (m)	Wavelength (nm)	Package	Temp. (°C)	TX Power (dBm)	RX Sens. (dBm)	RoHS Compliant
GBM-9000FG	2.125/1.063	2x/1x	150/300*	850	SC GBIC	0 to 70	-4 to -9.5	-17	Yes

\* At 2.125Gb/s: 150 m using 62.5 µm MMF optic cable; 300 m using 50 µm MMF optic cable

Absolute Maximum Ratings					
Parameter	Symbol	Min	Max	Units	Notes
Storage Temperature	Tstg	-40	85	°C	
Operating Temperature	Topt	-5	70	°C	Air flow 1m/sec
Power Supply Voltage	Vcc	-0.5	6	V	
Input Voltage	---	-0.5	Vcc	V	

Recommended Operating Conditions						
Parameter	Symbol	Min	Typ	Max	Units	Conditions
Power Supply Voltage	Vcc	4.75	5	5.25	V	Reference to GND.
Power Supply Current	ITX + IRX		200	300	mA	
Operating Temperature	Topt	0		70	°C	Air flow 1m/sec
Data Rate			1.0625 / 1.25 2.125 / 2.5	2.5	Gb/s	
Fiber Length on 50/125 µm 500MHz-km Fiber				550 300	m	@1.0625 Gb/s @2.125Gb/s
Fiber Length on 62.5/125 µm 200MHz-km Fiber				300 150	m	@1.0625 Gb/s @2.125Gb/s

\*\*\*\*\*

**Transmitter Specifications (0°C < Topr < 70°C, 4.75 V < Vcc < 5.25V)**

Parameter	Symbol	Min	Typ	Max	Units	Notes
<b>Optical</b>						
Optical Transmit Power	P <sub>o</sub>	-9.5	---	-4	dBm	1
Output Center Wavelength	λ	830	850	860	nm	
Output Spectrum Width	Δλ		---	0.85	nm	RMS (σ)
Extinction Ratio	E <sub>R</sub>		9	---	dB	
Optical Modulation Amplitude (Peak-to-Peak)	OMA	196			μW	FC-PI Standard
Optical Rise Time	t <sub>r</sub>			150	ps	20% to 80% value
Optical Fall Time	t <sub>f</sub>			150	ps	20% to 80% value
Relative Intensity Noise	RIN			-117	dB/Hz	
Pout TX_Disable Asserted	P <sub>OFF</sub>			-35	dBm	
<b>Electrical</b>						
Differential Input Voltage	V <sub>IH</sub> - V <sub>IL</sub>	0.65		2.0	V <sub>p-p</sub>	
Transmit Fault Load	TX-FAULT <sub>LOAD</sub>	4.7		10	kΩ	2
Transmit Fault Output-Low	V <sub>TX-FAULT-L</sub>	0.0		0.5	V	
Transmit Fault Output-High	V <sub>TX-FAULT-H</sub>	V <sub>cc</sub> - 0.5		V <sub>cc</sub> + 0.3	V	
TX-Disable Input - Low	V <sub>TX-DISABLE-L</sub>	0		0.8	V	
TX-Disable Input - High	V <sub>TX-DISABLE-H</sub>	2.0		V <sub>cc</sub> + 0.3	V	
TX-Disable Assert Time	t <sub>off</sub>			10	μs	
TX-Disable Negate Time	t <sub>on</sub>			1	ms	
Time to initialize, includes reset of TX-FAULT	t <sub>int</sub>			300	ms	
TX FAULT from fault to assertion	t <sub>fault</sub>			100	μs	
TX-Disable time to start reset	t <sub>reset</sub>	10			μs	

1. Output power is power coupled into a 62.5/125 μm or 50/125 μm MM fiber.
2. Pull-up resistor on host Vcc.

**Receiver Specifications (0°C < Topr < 70°C, 4.75 V < Vcc < 5.25V)**

Parameter	Symbol	Min	Typ	Max	Units	Notes
<b>Optical</b>						
Sensitivity @ 1.25Gb/s @ BER=10 <sup>-12</sup>	Sens (1X)	---	---	-18	dBm	3
Sensitivity @ 2.125Gb/s @ BER=10 <sup>-12</sup>	Sens (2X)			-17	dBm	3
Maximum Input Power	Pin	-3		---	dBm	3
Signal detect – Hysteresis		1.0	---		dB	
Wavelength of Operation		820	---	860	nm	
RX-LOS – Asserted	Pa	---	---	-17	dBm	Transition: low to high
RX-LOS – Deasserted	Pd	-31	---	---	dBm	Transition: high to low
<b>Electrical</b>						
Differential Output Voltage	±RX-DAT	0.37		2.0	V <sub>p-p</sub>	
Data Output Rise Time	T <sub>IRX-DAT</sub>			0.35	ns	
Data Output Fall Time	T <sub>IFRX-DAT</sub>			0.35	ns	
Receiver Loss of Light Load	RX-LOS <sub>LOAD</sub>	4.7		10	kΩ	4
Loss of Signal Output Voltage --- Low	RX-LOS <sub>L</sub>	0		0.8	V	
Loss of Signal Output Voltage --- High	RX-LOS <sub>H</sub>	2.4		V <sub>cc</sub>	V	
Loss of Signal Assert Time (off to on)	T <sub>A,RX-LOS</sub>			100	μs	
Loss of Signal Deassert Time (on to off)	T <sub>D,RX-LOS</sub>			100	μs	

3. Minimum sensitivity and saturation levels at BER=1E-12 for a 2<sup>7</sup>-1 PRBS.
4. Pull-up resistor on host Vcc.

\*\*\*\*\*

PIN ASSIGNMENT

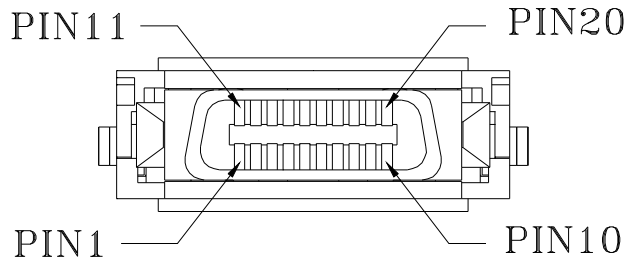

PIN	Signal Name	Sequence	Description
1	RX-LOS	2	Receiver Loss of Signal, logic high, open collector compatible, 4.7K to 10K ohm pull-up to V <sub>CC</sub> T on host
2	R <sub>GND</sub>	2	Receiver Ground
3	R <sub>GND</sub>	2	Receiver Ground
4	MOD-DEF(0)	2	TTL Low
5	MOD-DEF(1)	2	SCL Serial Clock Signal
6	MOD-DEF(2)	2	SDA Serial Data Signal
7	TX-DIABLE	2	Transmitter Disable, logic high, open collector compatible
8	T <sub>GND</sub>	2	Transmitter Ground
9	T <sub>GND</sub>	2	Transmitter Ground
10	TX-FAULT	2	Transmitter Fault, logic high, open collector compatible, 4.7K to 10K ohm pull-up to V <sub>CC</sub> T on GBIC
11	R <sub>GND</sub>	1	Receiver Ground
12	-RX-DAT	1	Receiver Data Bar, Differential PECL, AC coupled
13	+RX-DAT	1	Receiver Data, Differential PECL, AC coupled
14	R <sub>GND</sub>	1	Receiver Ground
15	V <sub>CC</sub> R	2	Receiver +5V Supply
16	V <sub>CC</sub> T	2	Transmitter +5V Supply
17	T <sub>GND</sub>	1	Transmitter Ground
18	+TX-DAT	1	Transmitter Data, Differential PECL, AC coupled
19	-TX-DAT	1	Transmitter Data Bar, Differential PECL, AC coupled
20	T <sub>GND</sub>	1	Transmitter Ground

A sequence value of 1 indicates that the signal is in the first group to engage during plugging of a module. A sequence value of 2 indicates that the signal is the second and last group. The two guide pins on the connector are electrically connected to the transceiver circuit ground. These two guide pins make contact with circuit prior to sequence 1 signals.

### Module Definition

Module Definition	MOD-DEF(0) PIN 4	MOD-DEF (1) PIN 5	MOD-DEF (2) PIN 6	Interpretation by Host
4	TTL Low	SCL	SDA	Serial module definition protocol

Module Definition 4 specifies a serial definition protocol. For this definition, upon power up, MOD-DEF(1:2) appear as no connector (NC) and MOD-DEF(0) is TTL LOW. When the host system detects this condition, it activates the serial protocol. The protocol uses the 2-wire serial CMOS E<sup>2</sup>PROM protocol of the ATMEL AT24C01A/02/04 family of components.

PACKAGE DIAGRAM

Units in mm

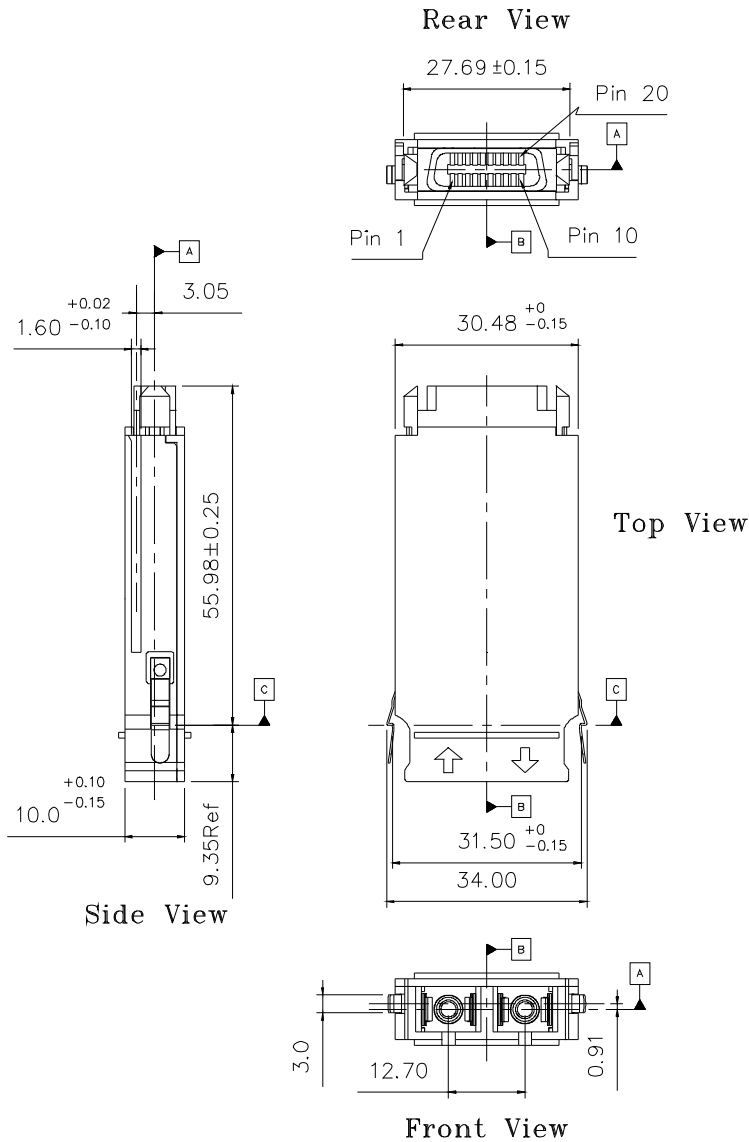

**Note:** Specifications subject to change without notice.