



SPECIFICATIONS FOR LCD MODULE

MODEL	WM-C1601M-1TNNc
CUSTOMER APPROVED	

台中縣潭子鄉 427 台中加工出口區建國路 9 號之 2
9-2, CHIEN-KUO RD., TEPZ TANTZU, TAICHUNG 427, TAIWAN, R.O.C.
TEL: 886-4-25347288, FAX: 886-4-25310868

Contents	Page
(1) Electronic Units	4
1.1 Absolute Maximum Ratings.....	4
1.2 Electrical Characteristics	4
1.3 Interface Pin Function.....	5
1.4 Power Supply for LCD Module	6
1.5 Block Diagram with Display RAM Address and Initialization Table	7
1.6 Character Generator Rom map.....	8
(2) Electro-optical Units	9
2.1 Electro-optical Characteristics	9
2.2 Optical Definitions	9
(3) Mechanical Units	11
3.1 Mechanical Specification	11
3.2 Mechanical Diagram	12
3.3 Packing Method	13
(4) Quality Units	14
4.1 Specification of Quality Assurance	14
4.2 Standard Specification for Reliability	21
4.3 Precautions in Use of LCM	23

Reference Data :
Sitronix ST7066U-0A Specifications

(1) Electronic Units

1.1 Absolute Maximum Ratings

ITEM	SYMBOL	MIN.	TYP.	MAX.	UNIT
OPERATING TEMPERATURE	T_{OP}	0	-	+50	°C
STORAGE TEMPERATURE	T_{ST}	-20	-	+70	°C
INPUT VOLTAGE	V_I	-0.3	-	$V_{DD} + 0.3$	V
SUPPLY VOLTAGE FOR LOGIC	$V_{DD}-V_{SS}$	-0.3	-	+7.0	V
SUPPLY VOLTAGE FOR LCD	$V_{DD}-V_0$	$V_{DD}-10$	-	$V_{DD} + 0.3$	V
STATIC ELECTRICITY	Be sure that you are grounded when handing LCM.				

1.2 Electrical Characteristics (V_{DD}=5.0V, T_a=25 °C)

ITEM	SYMBOL	CONDITION	MIN.	TYP.	MAX.	UNIT
SUPPLY VOLTAGE FOR LOGIC	$V_{DD} - V_{SS}$	-	4.5	5.0	5.5	V
SUPPLY VOLTAGE FOR LCD	$V_{DD} - V_0$	-	4.3	4.5	4.7	V
INPUT HIGH VOL	V_{IH}	-	0.7 V_{DD}	-	V_{DD}	V
INPUT LOW VOL	V_{IL}	-	-	-	0.2 V_{DD}	V
OUTPUT HIGH VOL	V_{OH}	$I_{OH} = -0.04mA$	0.9 V_{DD}	-	V_{DD}	V
OUTPUT LOW VOL.	V_{OL}	$I_{OL} = 0.04mA$	-	-	0.1 V_{DD}	V
SUPPLY CURRENT FOR LOGIC	* I_{DD}	$V_{DD} = 5.0V$	-	2.5	3.0	mA
USED IC	ST7066U-0A					

* I_{DD} Measurement condition is for all pixels on display

1.3 Interface Pin Function

CN1:

NO	SYMBOL	I/O	FUNCTION
1	V _{SS}	P	GND (0V)
2	V _{DD}	P	V _{DD} (+5V ± 5%)
3	V ₀	I	CONTRAST ADJUSTMENT
4	RS	I	REGISTER SELECT SIGNAL
5	R/W	I	READ / WRITE SELECTION
6	E	I	ENABLE SIGNAL
7	DB0	I/O	DATA BUS
8	DB1	I/O	
9	DB2	I/O	
10	DB3	I/O	
11	DB4	I/O	
12	DB5	I/O	
13	DB6	I/O	
14	DB7	I/O	
15	NC	-	NO CONNECTION
16	NC	-	NO CONNECTION

1.4 Power Supply for LCD Module

1. Signal Supply Voltage Types

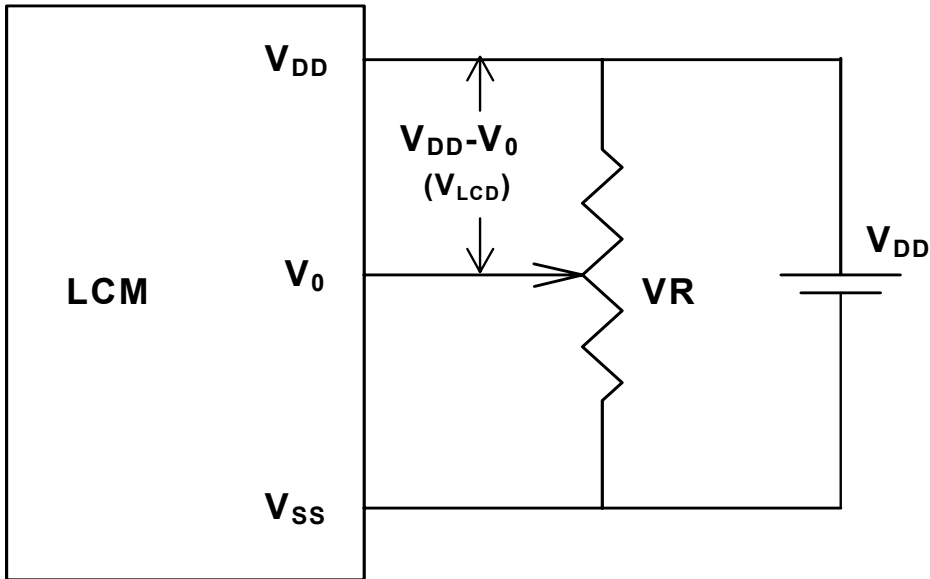

$V_{DD} - V_0$: LCD Driving Voltage

2. Dual Supply Voltage Types

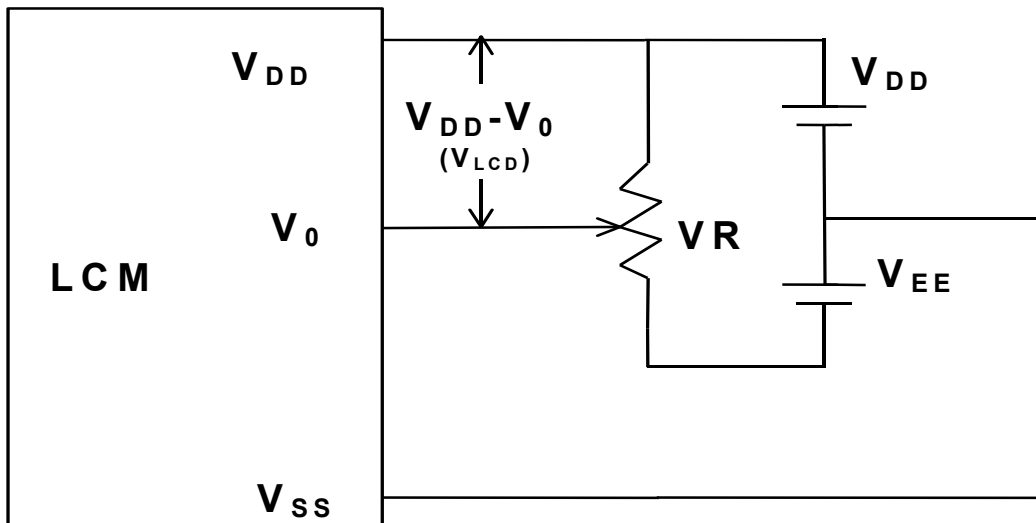

$V_{DD} - V_0$: LCD Driving Voltage

1.5 Block Diagram with Display RAM Address and Initialization Table

Relations between DDRAM addresses and positions on the LCD are shown below. The DDRAM address (ADD) is set in the address counter (AC) and is represented in hexadecimal.

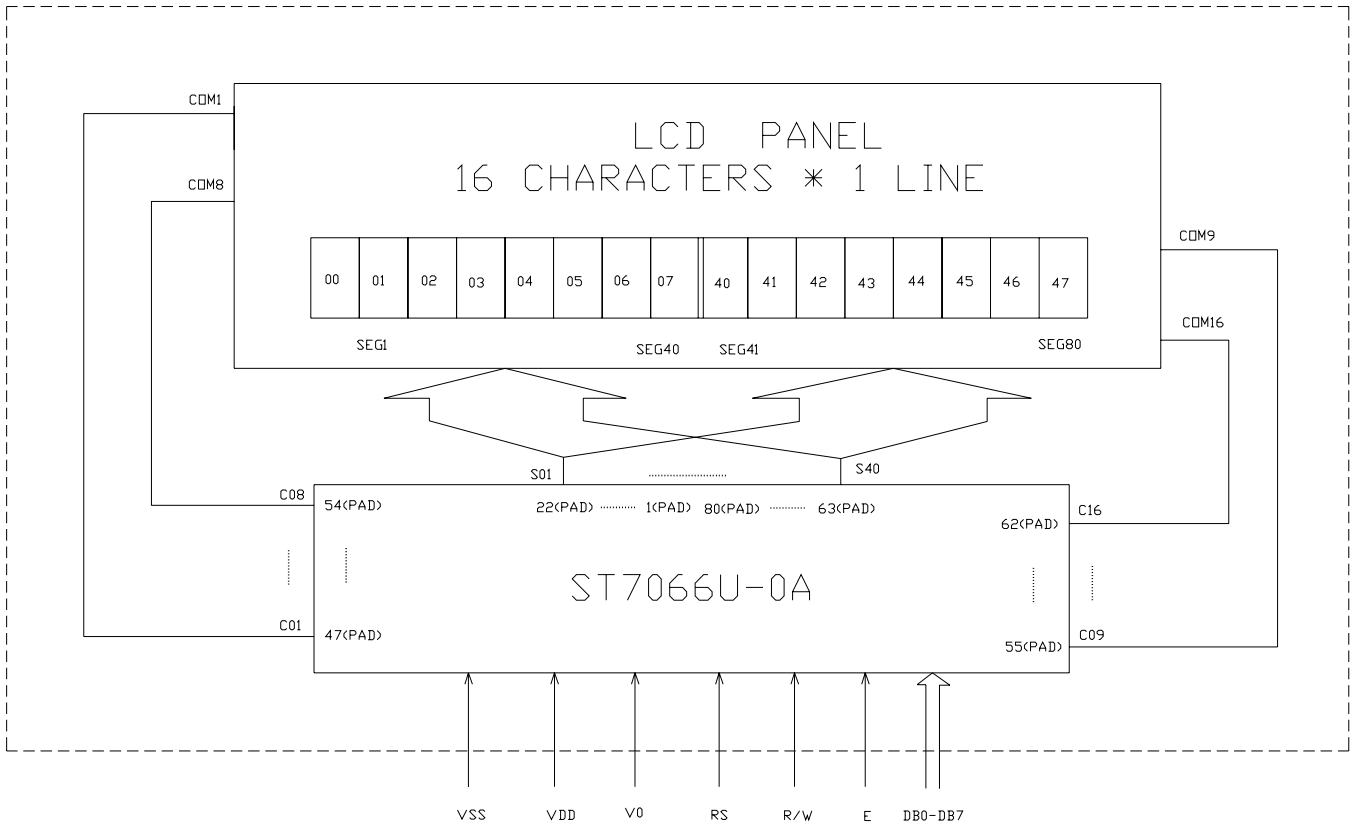

Initialization Table:

	Instruction	Code	Description
1.	Function Set	001110xx	8-Bit, 2-Line, 5x8 Dots, 1/16 Duty

1.6 Character Generator Rom map

b7-b4 b3-b0	0000	0001	0010	0011	0100	0101	0110	0111	1000	1001	1010	1011	1100	1101	1110	1111
0000	CG RAM (1)			0	1	2	3	4				5	6	7	8	9
0001	(2)	!	1	A	a						.	7	8	9		
0010	(3)	"	2	B	b						7	4	9	×	8	9
0011	(4)	#	3	C	c						1	7	7	7	7	7
0100	(5)	*	4	D	d						√	1	1	1	1	1
0101	(6)	%	5	E	e						*	*	*	1	1	1
0110	(7)	&	6	F	f						7	0	2	3	4	5
0111	(8)	'	7	G	g						7	7	×	7	9	1
1000	(1)	(8	H	h						4	0	*	1	1	1
1001	(2))	9	I	i						9	7	1	1	1	1
1010	(3)	*	:	J	j						2	0	0	1	1	1
1011	(4)	+	;	K	k						*	7	1	0	0	0
1100	(5)	,	<	L	l						7	0	7	7	0	0
1101	(6)	-	=	M	m						3	2	0	1	1	1
1110	(7)	.	>	N	n						3	1	0	0	0	0
1111	(8)	/	?	O	o						9	9	7	0	0	0

(2) Electro-optical Units

2.1 Electro-optical Characteristics

ITEM	SYMBOL	CONDITION	MIN.	TYP.	MAX.	UNIT
VIEW ANGLE (V)	θ	$CR \geq 2$	0	-	+30	deg.
VIEW ANGLE (H)	ϕ	$CR \geq 2$	-30	-	+30	deg.
CONTRAST RATIO	CR	Ta=25°C	-	4	-	-
RESPONSE TIME	tr	Ta=25°C	150	-	300	ms
RESPONSE TIME	td	Ta=25°C	150	-	300	ms
OPERATING VOLTAGE FOR LCD	V _{LCD}	Ta=25°C	4.3	4.5	4.7	V
DRIVE METHOD	DUTY	1/16				
	BIAS	1/5				
LCD TYPE	TN (Positive / Reflective)					
VIEWING DIRECTION	6 O'CLOCK					

2.2 Optical Definitions

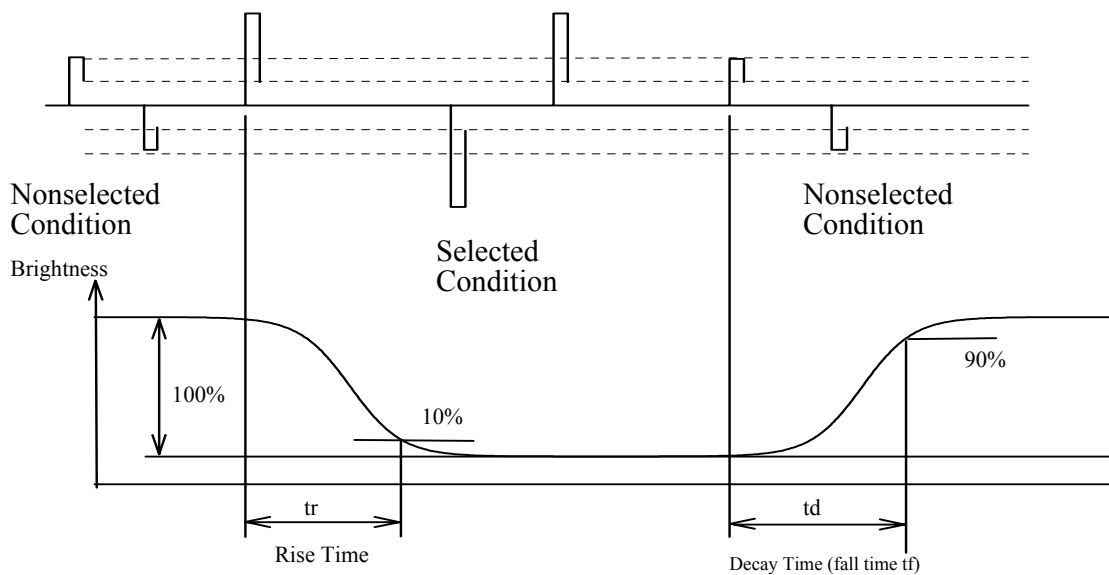

Response Time

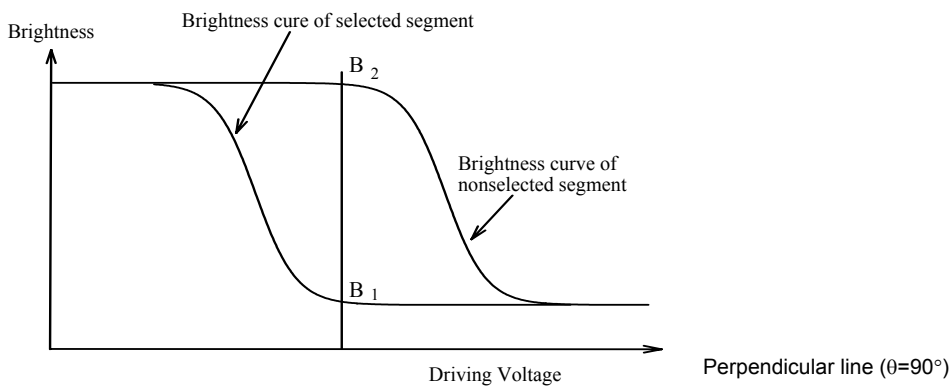
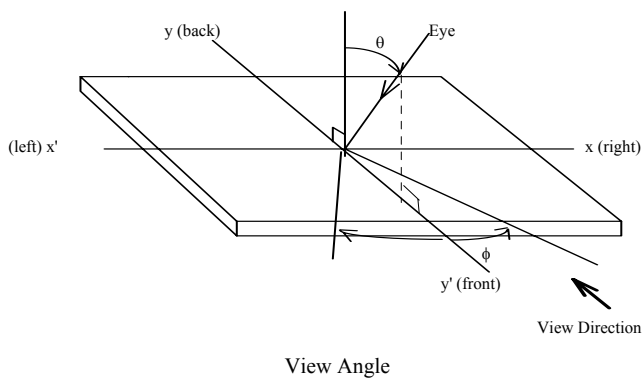
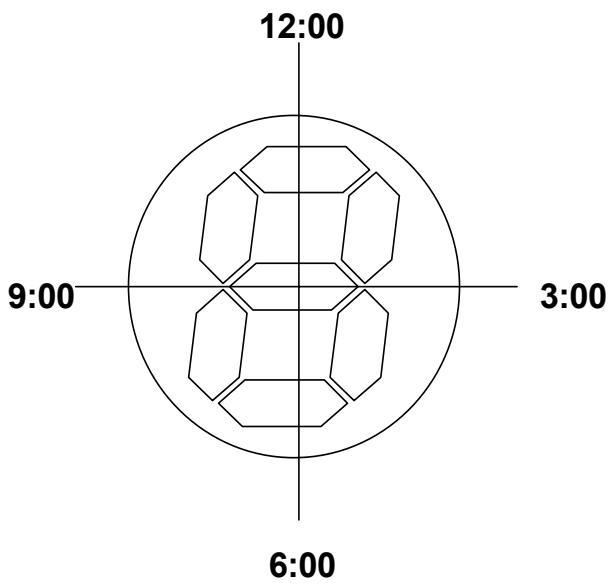

$$\text{Contrast ration} = \frac{\text{Brightness at nonselected segment (B2)}}{\text{Brightness at selected segment (B1)}}$$

Contrast ration (CR)

(3) Mechanical Units

3.1 Mechanical Specification

ITEM	STANDARD VALUE	UNIT
NUMBER OF CHARACTERS	16(CHARACTER) × 1(LINE)	-
CHARACTER FORMAT	5 × 8	dot
MODULE DIMENSION	80.0 (W) × 36.0 (H) × 9.5 (MAX)(T)	mm
VIEWING AREA	64.5 (W) × 15.0 (H)	mm
ACTIVE AREA	59.62 (W) × 6.56 (H)	mm
DOT SIZE	0.55 (W) × 0.75 (H)	mm
DOT PITCH	0.63 (W) × 0.83 (H)	mm
CHARACTER SIZE	3.07 (W) × 6.56 (H)	mm
CHARACTER PITCH	3.77 (W) × 6.56 (H)	mm
APPROX. WEIGHT	24.9	g
BACK LIGHT	-	

3.2 Mechanical Diagram

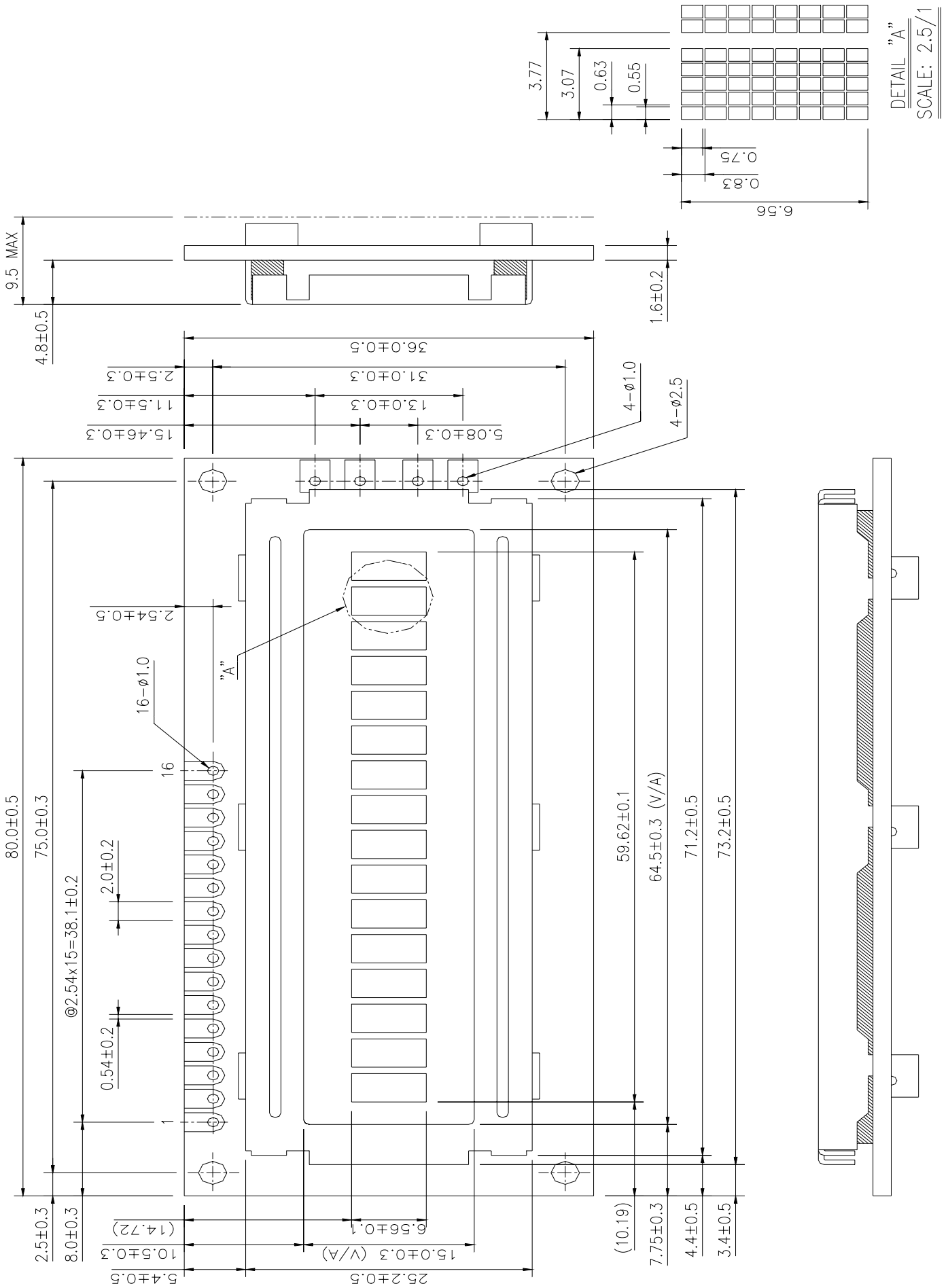

3.3 Packing Method

1. Packaging Material : (per carton)						
NO	Item	Model	Dimensions (mm)	Unit Weight (Kg)	Quantity	
1	LCM Module	WM-C1601M-1TNNc	80.0*36.0	0.0249	320	
2	Tray	V186	PETA	320*217	0.06	50
3	Product Box	C01	320*219*70	0.131	10	
4	Carton	C61	475*345*389	1.208	1	
5	Package Bag	C5	467*321*0.08	0.023	10	
6	Total Weight	13.8	Kg.±5%			

2. Packaging Specifications and Quantity :

- (1) LCM quantity per tray : no per row 2 x no per column 4 = 8
 (2) LCM quantity per box : no of trays 8 x quantity per tray 4 = 32
 (3) Total LCM quantity in carton : no of boxes 32 x quantity per box 10 = 320

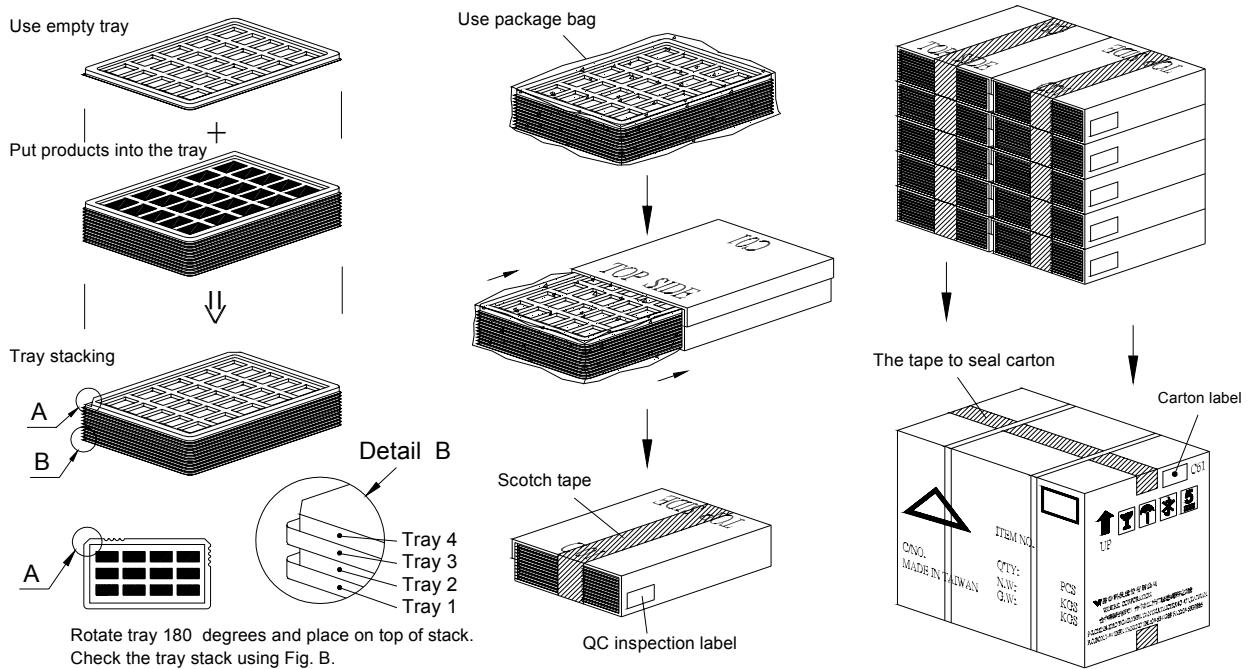

3. Label Specifications :

(1) QC Inspection Label

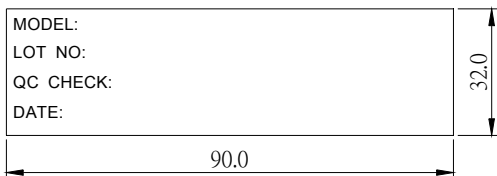

Label Color----Green

(2) Carton Label

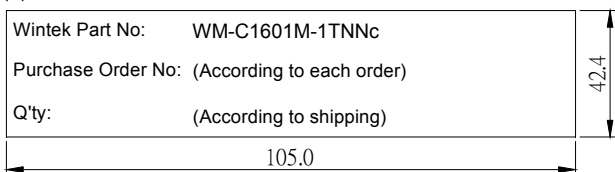

Label Color----White

Remark

(4) Quality Units

4.1 Specification of Quality Assurance

1. Purpose

This standard for Quality Assurance should affirm the quality of LCD module products to supply to purchaser by WINTEK CORPORATION (Supplier).

2. Standard for Quality Test

2.1 Inspection :

Before delivering, the supplier should take the following tests, and affirm the quality of product.

2.2 Electro-Optical Characteristics:

According to the individual specification to test the product.

2.3 Test of Appearance Characteristics:

According to the individual specification to test the product.

2.4 Test of Reliability Characteristics:

According to the definition of reliability on the specification for testing products.

2.5 Delivery Test:

Before delivering, the supplier should take the delivery test.

2.5.1 Test method: According to MIL-STD-105E, General Inspection Level II take a single time.

2.5.2 The defects classify of AQL as following:

Major defect: AQL=0.65

Minor defect: AQL=2.5

Total defects: AQL=2.5

3. Nonconforming Analysis & Deal With Manners

3.1 Nonconforming analysis:

3.1.1 Purchaser should supply the detail data of non-conforming sample and the non-suitable state.

3.1.2 After accepting the detail data from purchaser, the analysis of nonconforming should be finished in two weeks.

3.1.3 If supplier can not finish analysis on time, must announce purchaser before two weeks.

3.2 Disposition of nonconforming:

3.2.1 If find any product defect of supplier during assembly time, supplier must change the good product for every defect after recognition.

3.2.2 Both supplier and customer should analyze the reason and discuss the disposition of nonconforming when the reason of nonconforming is not sure.

4. Agreement items

Both sides should discuss together when the following problems happen.

- 4.1 There is any problem of standard of quality assurance, and both sides think that it must be modified.
- 4.2 There is any argument item which does not record in the standard of quality assurance.
- 4.3 Any other special problem.

5. Standard of The Product Appearance Test

5.1 Manner of appearance test:

- 5.1.1 The test must be under 20W x 2 or 40W fluorescent light, and the distance of view must be at 30 cm.
- 5.1.2 When test the model of transmissive product must add the reflective plate.
- 5.1.3 The test direction is base on about around 45° of vertical line.

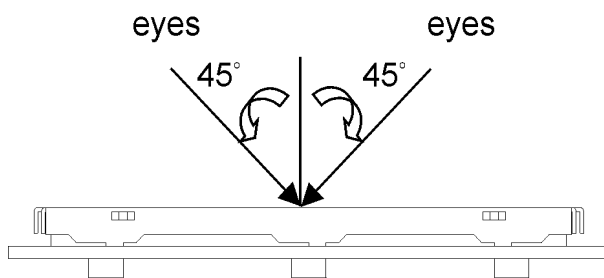

5.1.4 Definition of area:

- A Area : Viewing area.
- B Area : Out of viewing area.
(Outside viewing area)

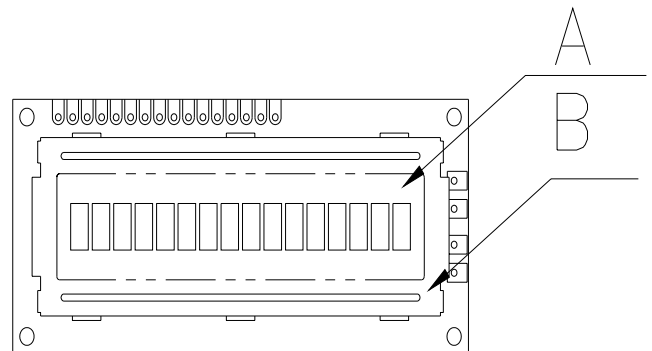

5.2 Basic principle:

- 5.2.1 It will accord to the AQL when the standard can not be described.
 - 5.2.2 The sample of the lowest acceptable quality level must be discussed by both supplier and customer when any dispute happened.
 - 5.2.3 Must add new item on time when it is necessary.
- 5.3 Standard of inspection:(Unit: mm)

6. Inspection specification

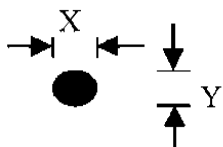
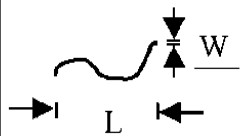
NO	Item	Criterion	AQL												
01	Electrical Testing	1.1 Missing vertical, horizontal segment, segment contrast defect. 1.2 Missing character , dot or icon. 1.3 Display malfunction. 1.4 No function or no display. 1.5 Current consumption exceeds product specifications. 1.6 LCD viewing angle defect. 1.7 Mixed product types. 1.8 Contrast defect.	0.65												
02	Black or white spots on LCD (display only)	2.1 White and black spots on display $\leq 0.25\text{mm}$, no more than three white or black spots present. 2.2 Densely spaced: No more than two spots or lines within 3mm.	2.5												
03	LCD black spots, white spots, contamination (non-display)	3.1 Round type : As following drawing $\phi = (x + y) / 2$  <table border="1" data-bbox="726 1064 1308 1355"> <thead> <tr> <th>SIZE</th> <th>Acceptable Q TY</th> </tr> </thead> <tbody> <tr> <td>$\phi \leq 0.10$</td> <td>Accept no dense</td> </tr> <tr> <td>$0.10 < \phi \leq 0.20$</td> <td>2</td> </tr> <tr> <td>$0.20 < \phi \leq 0.25$</td> <td>1</td> </tr> <tr> <td>$0.25 < \phi$</td> <td>0</td> </tr> </tbody> </table>	SIZE	Acceptable Q TY	$\phi \leq 0.10$	Accept no dense	$0.10 < \phi \leq 0.20$	2	$0.20 < \phi \leq 0.25$	1	$0.25 < \phi$	0	2.5		
		SIZE	Acceptable Q TY												
$\phi \leq 0.10$	Accept no dense														
$0.10 < \phi \leq 0.20$	2														
$0.20 < \phi \leq 0.25$	1														
$0.25 < \phi$	0														
3.2 Line type : (As following drawing)  <table border="1" data-bbox="654 1478 1340 1758"> <thead> <tr> <th>Length</th> <th>Width</th> <th>Acceptable Q TY</th> </tr> </thead> <tbody> <tr> <td>--</td> <td>$W \leq 0.02$</td> <td>Accept no dense</td> </tr> <tr> <td>$L \leq 3.0$</td> <td>$0.02 < W \leq 0.03$</td> <td rowspan="2">2</td> </tr> <tr> <td>$L \leq 2.5$</td> <td>$0.03 < W \leq 0.05$</td> </tr> <tr> <td>--</td> <td>$0.05 < W$</td> <td>As round type</td> </tr> </tbody> </table>	Length	Width	Acceptable Q TY	--	$W \leq 0.02$	Accept no dense	$L \leq 3.0$	$0.02 < W \leq 0.03$	2	$L \leq 2.5$	$0.03 < W \leq 0.05$	--	$0.05 < W$	As round type	2.5
Length	Width	Acceptable Q TY													
--	$W \leq 0.02$	Accept no dense													
$L \leq 3.0$	$0.02 < W \leq 0.03$	2													
$L \leq 2.5$	$0.03 < W \leq 0.05$														
--	$0.05 < W$	As round type													

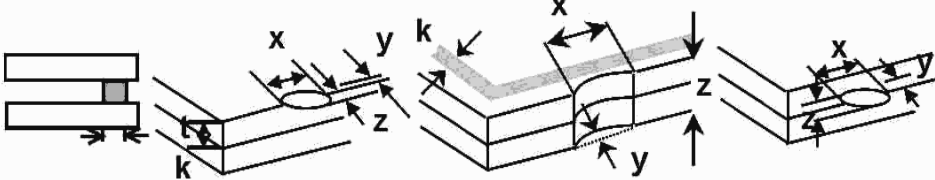
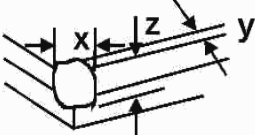
NO	Item	Criterion	AQL																		
04	Polarizer bubbles	<p>If bubbles are visible, judge using black spot specifications, not easy to find, must check in specify direction</p> <table border="1" data-bbox="775 353 1323 663"> <thead> <tr> <th>Size ϕ</th> <th>Acceptable Q TY</th> </tr> </thead> <tbody> <tr> <td>$\phi \leq 0.20$</td> <td>Accept no dense</td> </tr> <tr> <td>$0.20 < \phi \leq 0.50$</td> <td>3</td> </tr> <tr> <td>$0.50 < \phi \leq 1.00$</td> <td>2</td> </tr> <tr> <td>$1.00 < \phi$</td> <td>0</td> </tr> <tr> <td>Total Q TY</td> <td>3</td> </tr> </tbody> </table>	Size ϕ	Acceptable Q TY	$\phi \leq 0.20$	Accept no dense	$0.20 < \phi \leq 0.50$	3	$0.50 < \phi \leq 1.00$	2	$1.00 < \phi$	0	Total Q TY	3	2.5						
Size ϕ	Acceptable Q TY																				
$\phi \leq 0.20$	Accept no dense																				
$0.20 < \phi \leq 0.50$	3																				
$0.50 < \phi \leq 1.00$	2																				
$1.00 < \phi$	0																				
Total Q TY	3																				
05	Scratches	Follow NO.3 LCD black spots, white spots, contamination																			
06	Chipped glass	<p>Symbols :</p> <p>x : Chip length y : Chip width z : Chip thickness k : Seal width t : Glass thickness a : LCD side length L : Electrode pad length</p> <p>6.1 General glass chip :</p> <p>6.1.1 Chip on panel surface and crack between panels :</p>  <table border="1" data-bbox="440 1274 1319 1447"> <thead> <tr> <th>z : Chip thickness</th> <th>y : Chip width</th> <th>x : Chip length</th> </tr> </thead> <tbody> <tr> <td>$Z \leq 1/2t$</td> <td>Not over viewing area</td> <td>$x \leq 1/8a$</td> </tr> <tr> <td>$1/2t < z \leq 2t$</td> <td>Not exceed 1/3k</td> <td>$x \leq 1/8a$</td> </tr> </tbody> </table> <p>⊙ If there are 2 or more chips, x is the total length of each chip.</p> <p>6.1.2 Corner crack :</p>  <table border="1" data-bbox="440 1650 1319 1823"> <thead> <tr> <th>z : Chip thickness</th> <th>y : Chip width</th> <th>x : Chip length</th> </tr> </thead> <tbody> <tr> <td>$Z \leq 1/2t$</td> <td>Not over viewing area</td> <td>$x \leq 1/8a$</td> </tr> <tr> <td>$1/2t < z \leq 2t$</td> <td>Not exceed 1/3k</td> <td>$x \leq 1/8a$</td> </tr> </tbody> </table> <p>⊙ If there are 2 or more chips, x is the total length of each chip.</p>	z : Chip thickness	y : Chip width	x : Chip length	$Z \leq 1/2t$	Not over viewing area	$x \leq 1/8a$	$1/2t < z \leq 2t$	Not exceed 1/3k	$x \leq 1/8a$	z : Chip thickness	y : Chip width	x : Chip length	$Z \leq 1/2t$	Not over viewing area	$x \leq 1/8a$	$1/2t < z \leq 2t$	Not exceed 1/3k	$x \leq 1/8a$	2.5
z : Chip thickness	y : Chip width	x : Chip length																			
$Z \leq 1/2t$	Not over viewing area	$x \leq 1/8a$																			
$1/2t < z \leq 2t$	Not exceed 1/3k	$x \leq 1/8a$																			
z : Chip thickness	y : Chip width	x : Chip length																			
$Z \leq 1/2t$	Not over viewing area	$x \leq 1/8a$																			
$1/2t < z \leq 2t$	Not exceed 1/3k	$x \leq 1/8a$																			

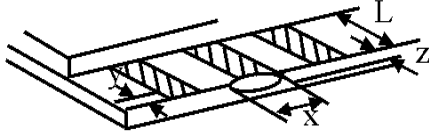
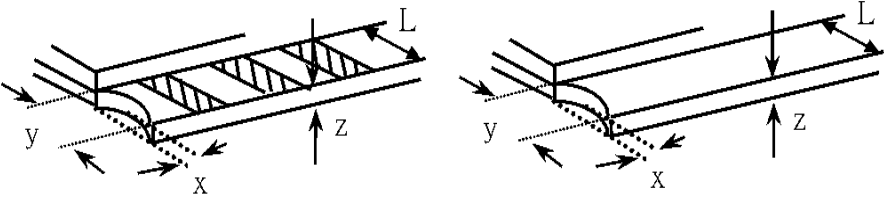
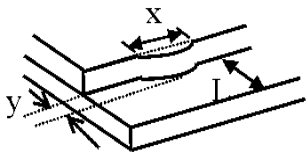
NO	Item	Criterion	AQL																
06	Glass crack	<p>Symbols :</p> <p>x : Chip length y : Chip width z : Chip thickness k : Seal width t : Glass thickness a : LCD side length L : Electrode pad length</p> <p>6.2 Protrusion over terminal :</p> <p>6.2.1 Chip on electrode pad :</p>  <table border="1" data-bbox="466 775 1315 900"> <tr> <td>y : Chip width</td> <td>x : Chip length</td> <td>z : Chip thickness</td> </tr> <tr> <td>$y \leq 0.5 \text{ mm}$</td> <td>$x \leq 1/8a$</td> <td>$0 < z \leq t$</td> </tr> </table> <p>6.2.2 Non-conductive portion :</p>  <table border="1" data-bbox="466 1240 1315 1357"> <tr> <td>y : Chip width</td> <td>x : Chip length</td> <td>z : Chip thickness</td> </tr> <tr> <td>$y \leq L$</td> <td>$x \leq 1/8a$</td> <td>$0 < z \leq t$</td> </tr> </table> <ul style="list-style-type: none"> ⊙ If the chipped area touches the ITO terminal, over 2/3 of the ITO must remain and be inspected according to electrode terminal specifications. ⊙ If the product will be heat sealed by the customer, the alignment mark must not be damaged. <p>6.2.3 Substrate protuberance and internal crack.</p>  <table border="1" data-bbox="785 1675 1315 1792"> <tr> <td>y : width</td> <td>x : length</td> </tr> <tr> <td>$y \leq 1/3L$</td> <td>$x \leq a$</td> </tr> </table>	y : Chip width	x : Chip length	z : Chip thickness	$y \leq 0.5 \text{ mm}$	$x \leq 1/8a$	$0 < z \leq t$	y : Chip width	x : Chip length	z : Chip thickness	$y \leq L$	$x \leq 1/8a$	$0 < z \leq t$	y : width	x : length	$y \leq 1/3L$	$x \leq a$	2.5
y : Chip width	x : Chip length	z : Chip thickness																	
$y \leq 0.5 \text{ mm}$	$x \leq 1/8a$	$0 < z \leq t$																	
y : Chip width	x : Chip length	z : Chip thickness																	
$y \leq L$	$x \leq 1/8a$	$0 < z \leq t$																	
y : width	x : length																		
$y \leq 1/3L$	$x \leq a$																		

NO	Item	Criterion	AQL
07	Cracked glass	The LCD with extensive crack is not acceptable.	2.5
08	Backlight elements	8.1 Illumination source flickers when lit.	0.65
		8.2 Spots or scratches that appear when lit must be judged using LCD spot, lines and contamination standards.	2.5
		8.3 Backlight doesn't light or color is wrong.	0.65
09	Bezel	9.1 Bezel may not have rust, be deformed or have fingerprints, stains or other contamination.	2.5
		9.2 Bezel must comply with job specifications.	0.65
10	PCB、COB	10.1 COB seal may not have pinholes larger than 0.2mm or contamination.	2.5
		10.2 COB seal surface may not have pinholes through to the IC.	2.5
		10.3 The height of the COB should not exceed the height indicated in the assembly diagram.	0.65
		10.4 There may not be more than 2mm of sealant outside the seal area on the PCB. And there should be no more than three places.	2.5
		10.5 No oxidation or contamination PCB terminals.	2.5
		10.6 Parts on PCB must be the same as on the production characteristic chart. There should be no wrong parts, missing parts or excess parts.	0.65
		10.7 The jumper on the PCB should conform to the product characteristic chart.	0.65
		10.8 If solder gets on bezel tab pads, LED pad, zebra pad or screw hole pad, make sure it is smoothed down.	2.5
11	Soldering	11.1 No unmelted solder paste may be present on the PCB.	2.5
		11.2 No cold solder joints, missing solder connections, oxidation or icicle.	2.5
		11.3 No residue or solder balls on PCB.	2.5
		11.4 No short circuits in components on PCB.	0.65

NO	Item	Criterion	AQL
12	General appearance	12.1 No oxidation, contamination, curves or, bends on interface Pin (OLB) of TCP.	2.5
		12.2 No cracks on interface pin (OLB) of TCP.	0.65
		12.3 No contamination, solder residue or solder balls on product.	2.5
		12.4 The IC on the TCP may not be damaged, circuits.	2.5
		12.5 The uppermost edge of the protective strip on the interface pin must be present or look as if it cause the interface pin to sever.	2.5
		12.6 The residual rosin or tin oil of soldering (component or chip component) is not burned into brown or black color.	2.5
		12.7 Sealant on top of the ITO circuit has not hardened	2.5
		12.8 Pin type must match type in specification sheet.	0.65
		12.9 LCD pin loose or missing pins.	0.65
		12.10 Product packaging must the same as specified on packaging specification sheet.	0.65
		12.11 Product dimension and structure must conform to product specification sheet .	0.65
		12.12 The appearance of Heat Seal should not admit any dirt and break.	

4.2 Standard Specification for Reliability

1. Standard Specifications for Reliability of LCD Module

No	Item	Description
01	High temperature operation	The sample should be allowed to stand at 50 °C for 240 (-0, +48) hours under driving condition.
02	Low temperature operation	The sample should be allowed to stand at 0 °C for 240 (-0, +48) hours under driving condition.
03	High temperature resistance	The sample should be allowed to stand at 70 °C for 240 (-0,+48) hours under no-load condition, and then returning it to normal temperature condition, and allowing it stand for 30 minutes.
04	Low temperature resistance	The sample should be allowed to stand at -20°C for 240 (-0,+48) hours under no-load condition, then returning it to normal temperature condition, and allowing it stand for 24 hours.
05	Moisture resistance	The sample should be allowed to stand at 40°C , 90 % RH MAX for 240 (-0,+48) hours under no-load condition excluding the polarizer, then taking it out and drying it at normal temperature.
06	Thermal shock resistance	The sample should be allowed to stand the following 10 cycles of operation: -40 °C for 30 minutes → normal temperature for 5 minutes → +80 °C for 30 minutes → normal temperature for 5 minutes, as one cycle.
07	ESD (Electrostatic Discharge)	Human Body Model: 2000 volt electrical discharge from a 100 pF capacitor to the tested device in series with a 1500 ohm resistor. Apply V_{DD} & V_{SS} to LCD module unit. Test for functionality no missing lines after the discharge, but LCD module may reset. Machine Model: 200 volt electrical discharge from a 200 pF capacitor to the tested device with no series resistance. Apply to V_{DD} & V_{SS} to LCD module unit without including hand phone. Test for functionality no any missing line after the discharge but LCD module can be reset if display off.

2. Testing Conditions and Inspection Criteria

For the final test the testing sample must be stored at room temperature for 24 hours, after the tests listed in Table 14.1, Standard specifications for Reliability have been executed in order to ensure stability.

NO	Item	Test Model	Inspection Criteria
01	Current Consumption	Refer To Specification	The current consumption should conform to the product specification.
02	Contrast	Refer To Specification	After the tests have been executed , the contrast must be larger than half of its initial value prior to the tests.
03	Appearance	Visual inspection	Defect free.

3. Life Time

Life time	Functions, performance, appearance, etc. shall be free from remarkable deterioration within 50,000 hours under ordinary operating and storage conditions room temperature (25 10°C), normal humidity (45 20% RH), and in area not exposed to direct sun light. (Life time of backlight, please refer to Data about backlight .)
-----------	---

Note: From our experience the life time of high humidity operation and high temperature operation as above mentioned could be achieved.

4.3 Precautions in Use of LCM

4.3.1 Handling of LCM

- Don't give external shock.
- Don't apply excessive force on the surface.
- Liquid in LCD is hazardous substance. Must not lick and swallow. when the liquid is attach to your hand, skin, cloth etc. Wash it out thoroughly and immediately.
- Don't operate it above the absolute maximum rating.
- Don't disassemble the LCM.

4.3.2 Storage

- Store in an ambient temperature of 5°C to 45°C , and in a relative humidity of 40% to 60%. Don't expose to sunlight or fluorescent light.
- Storage in a clean environment, free from dust, active gas, and solvent.
- Store in anti-static electricity container.
- Store without any physical load.

4.3.3 Soldering

- Use the high quality solder. (60-63% tin mixed with lead)
- Iron: no higher than 260°C and less than 3-4 sec during soldering.
- Soldering: only to the I/O terminals.
- Rewiring: no more than 3 times.