

Technical Data Sheet

7344/G2T3-AQTB/X

Features

- Popular T-1 3/4package.
- High efficiency.
- General purpose leads.
- Selected minimum intensities.
- Available on tape and reel.
- The product itself will remain within RoHS compliant version..
- ESD-withstand voltage: up to 4K V



Descriptions

- The series is specially designed for applications requiring higher brightness.
- The LED lamps are available with different colors, intensities, epoxy colors, etc.

Applications

- Status indicators.
- Commercial use.
- Advertising Signs.
- Back lighting.

Device Selection Guide

LED Part No.	Chip		Lens Color	Stopper
	Material	Emitted Color		
7344/G2T3-AQTB/P	InGaN	Super Green	Green Trans	Yes
7344/G2T3-AQTB				No

Technical Data Sheet

7344/G2T3-AQTB/X

Package Dimensions

Stopper type

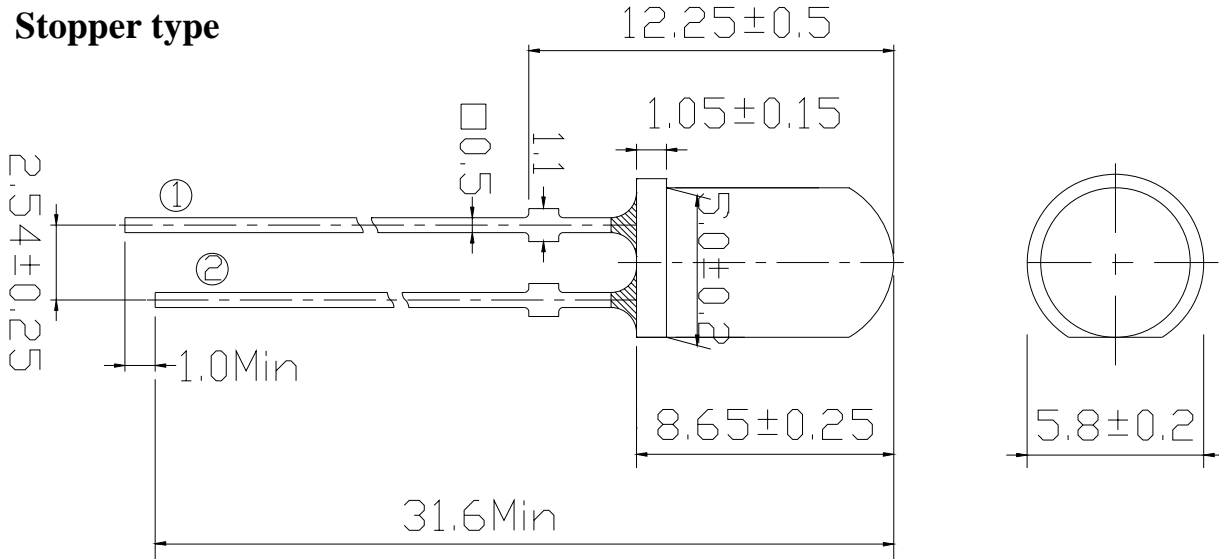

No Stopper type

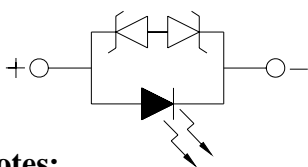
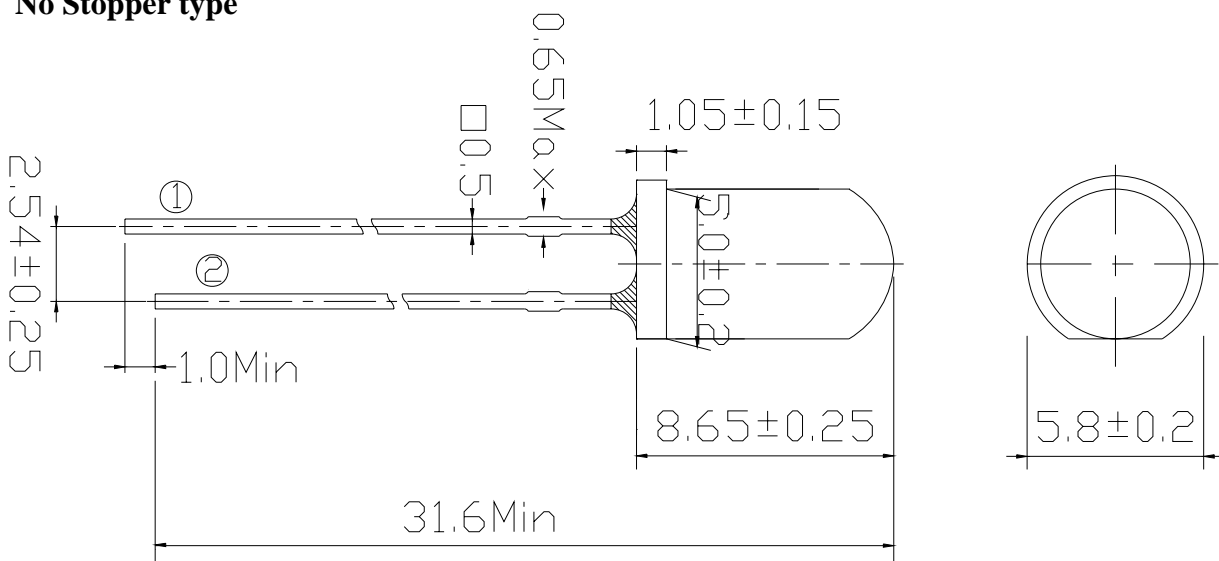

① Anode
② Cathode

Notes:

- Other dimensions are in millimeters, tolerance is 0.25mm except being specified.
- Protruded resin under flange is 1.5mm Max LED.
- Bare copper alloy is exposed at tie-bar portion after cutting.



Technical Data Sheet

7344/G2T3-AQTB/X

Absolute Maximum Rating ($T_a=25^{\circ}\text{C}$)

Parameter	Symbol	Absolute Maximum Rating	Unit
Forward Current	I_F	25	mA
Pulse Forward Current (Duty 1/10@ 1KHz)	I_{FP}	100	mA
Operating Temperature	T_{opr}	-40 ~ +85	$^{\circ}\text{C}$
Storage Temperature	T_{stg}	-40 ~ +100	$^{\circ}\text{C}$
Reverse Voltage	V_R	5	V
Electrostatic Discharge	ESD	4K	V
Soldering Temperature	T_{sol}	260 \pm 5	$^{\circ}\text{C}$
Power Dissipation	P_d	110	mW
Zener Reverse Current	I_z	100	mA

Notes: Soldering time \leq 5 seconds.

Electro-Optical Characteristics ($T_a=25^{\circ}\text{C}$)

Parameter	Symbol	Min.	Typ.	Max.	Unit	Condition
Radiometric Intensity	I_v	3600	5650	----	mcd	$I_F=20\text{mA}$
Viewing Angle	$2\theta_{1/2}$	----	30	----	deg	
Peak Wavelength	λ_p	----	518	----	nm	
Dominant Wavelength	λ_d	----	525	----		
Spectrum Half width	$\Delta\lambda$	----	35	----		
Forward Voltage	V_F	----	----	4.0	V	
Reverse Current	I_R	----	----	50	μA	$V_R=5\text{V}$
Zener Reverse Voltage	V_Z	5.2	----	----	V	$I_z=5\text{mA}$



Technical Data Sheet

7344/G2T3-AQTB/X

Rank Combination ($I_F=20mA$)

Rank	Q	R	S	T
Luminous Intensity	3600~4500	4500~5650	5650~7150	7150~9000

*Measurement Uncertainty of Luminous Intensity: $\pm 15\%$

Unit: :mcd

Rank	B				
	1	2	3	4	5
Forward Voltage	3.0~3.2	3.2~3.4	3.4~3.6	3.6~3.8	3.8~4.0

*Measurement Uncertainty of Forward Voltage: $\pm 0.1V$

Unit:V

Rank	3	4	5
Dominant Wavelength	520~524	524~528	528~532

*Measurement Uncertainty of Dominant Wavelength $\pm 1.0nm$

Unit:nm

Technical Data Sheet

7344/G2T3-AQTB/X

Typical Electro-Optical Characteristics Curves

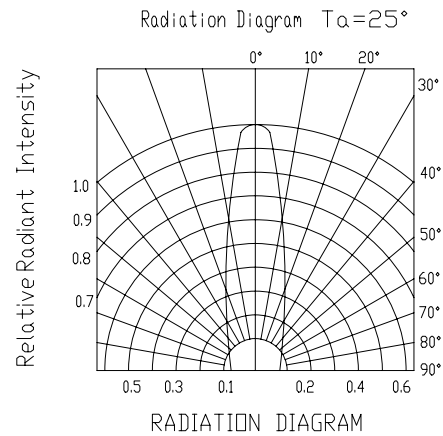
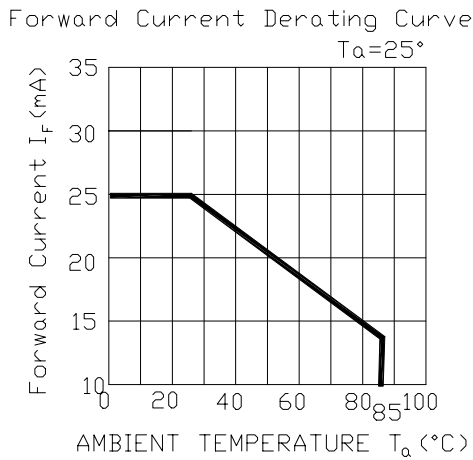
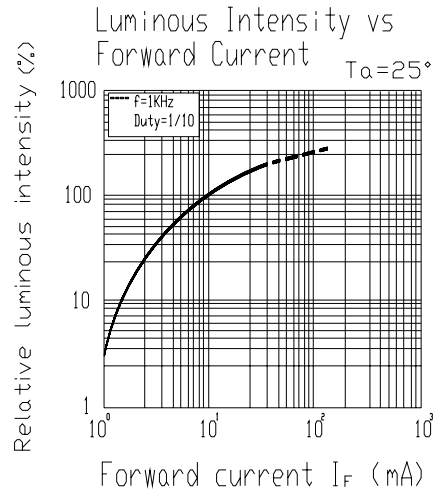
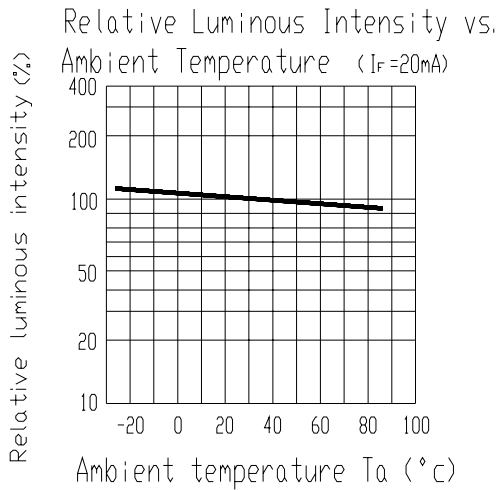
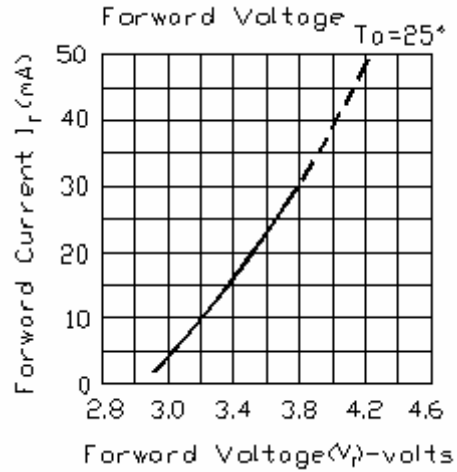
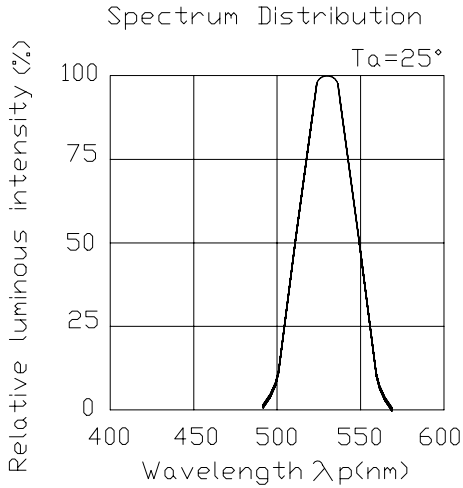



Technical Data Sheet

7344/G2T3-AQTB/X

Packing Quantity Specification

1.500PCS/1Bag , 5Bags/1Box

2.10Boxes/1Carton

Label Form Specification

EVERLIGHT	
CPN:	
P/N:	RoHS
7344/G2T3-AQTB/X	
QTY :	CAT:
	HUE:
LOT NO :	REF:
MADE IN TAIWAN	

CPN: Customer's Production Number

P/N : Production Number

QTY: Packing Quantity

CAT: Ranks of Luminous and Forward Voltage

HUE: Ranks of Dominant Wavelength

REF: Reference

LOT No: Lot Number

MADE IN TAIWAN: Production Place

Technical Data Sheet

7344/G2T3-AQTB/X

Notes

1. Above specification may be changed without notice. EVERLIGHT will reserve authority on material change for above specification.
2. When using this product, please observe the absolute maximum ratings and the instructions for using outlined in these specification sheets. EVERLIGHT assumes no responsibility for any damage resulting from use of the product which does not comply with the absolute maximum ratings and the instructions included in these specification sheets.
3. These specification sheets include materials protected under copyright of EVERLIGHT corporation. Please don't reproduce or cause anyone to reproduce them without EVERLIGHT's consent.
4. Below the zener reference voltage V_z , all the current flows through LED and as the voltage rises to V_z , the zener diode "breakdown." If the voltage tries to rise above V_z current flows through the zener branch to keep the voltage at exactly V_z .
5. When the LED is connected using serial circuit, if either piece of LED is no light up but current can't flow through causing others to light down. In new design, the LED is parallel with zener diode. if either piece of LED is no light up but current can flow through causing others to light up.

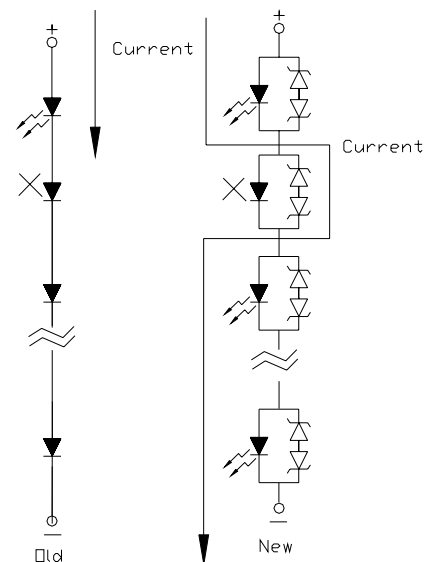



Technical Data Sheet

7344/G2T3-AQTB/X

6. Soldering Condition

Careful attention should be paid during soldering. When soldering, leave more than 3mm from solder joint to case, and soldering beyond the base of the tie bar is recommended.

Avoiding applying any stress to the lead frame while the LEDs are at high temperature particularly when soldering.

Recommended soldering conditions:

Hand Soldering		DIP Soldering	
Temp. at tip of iron	400°C Max. (30W Max.)	Preheat temp.	100°C Max. (60 sec Max.)
Soldering time	3 sec Max.	Bath temp.	265 Max.
Distance	3mm Min.(From solder joint to case)	Bath time.	5 sec Max.
		Distance	3mm Min.

EVERLIGHT ELECTRONICS CO., LTD.
Office: No 25, Lane 76, Sec 3, Chung Yang Rd,
Tucheng, Taipei 236, Taiwan, R.O.C

Tel: 886-2-2267-2000, 2267-9936
Fax: 886-2267-6244, 2267-6189, 2267-6306
<http://www.everlight.com>