

XFMRS, Inc.

SPECIFICATION FOR APPROVAL

XFMRS P/N : XFEB451616-750-3A **Rev: A/2**

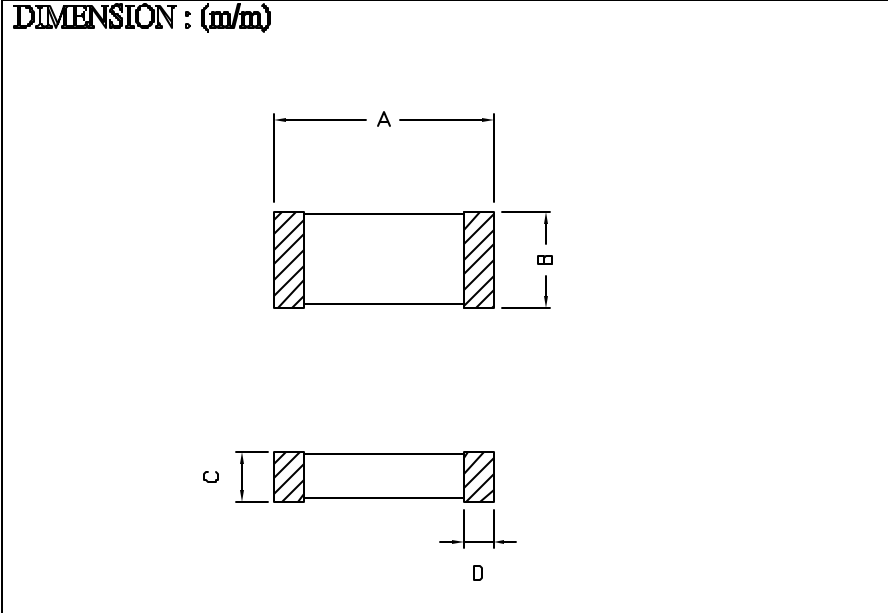

A	4.5±0.2	m/m
B	1.6±0.2	m/m
C	1.6±0.2	m/m
D	0.5±0.3	m/m
E		m/m
F		m/m
G		m/m
H		m/m
I		m/m
J		m/m
K		m/m
L		m/m
M		m/m
N		m/m
O		m/m

ELECTRICAL REQUIREMENTS

Z	75±25% Ohms	TEST FREQ.	100	MHz
Rdc	0.025 Ohms Max	TEST FREQ.		MHz
Idc	3000mAdc Max	TEST FREQ.		MHz

- Notes:**
- Solderability: Leads shall meet MIL-STD-202G, Method 208H for solderability.
 - Flammability: UL94V-0
 - ASTM oxygen index: > 28%
 - Insulation System: Class F 155°C. UL file E151556
 - Operating Temperature Range: All listed parameters are to be within tolerance from -40°C to +85°C
 - Storage Temperature Range: -55°C to +125°C
 - Aqueous wash compatible
 - SMD Lead Coplanarity: ±0.004"(0.102mm)
 - Electrical and mechanical specifications 100% tested
 - RoHS Compliant Component

TEST INSTRUMENTS

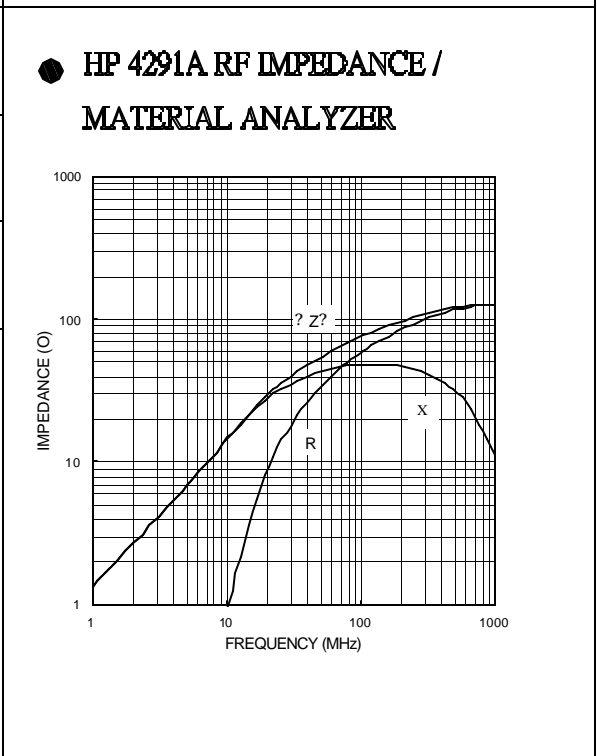

DRAWN BY :
Juan Mao
Apr-10-08

CHECKED BY :
YK Liao
Apr-10-08

APPROVED BY :
BW
Apr-10-08

PROPRIETARY Document is the property of XFMRS Group & is not allowed to be duplicated without authorization.