

# InGaAs Camera C10633-13, -23

## Near Infrared Camera



\* Shown with optional lens.

The C10633-13 and -23 are InGaAs cameras with high sensitivity in the infrared region, especially in wavelength range from 900 nm to 1700 nm. The C10633-13 and -23 support the standard video output (either EIA 60 Hz or CCIR 50 Hz) and the standard USB 2.0 to interface to PC for 14 bit image acquisition with exposure time control. It can be used for many IR applications, such as IR reflectography (art inspection), Si wafer inspection, Laser beam measurement, Solar cell evaluation and so on.

### FEATURES

- Good sensitivity in 900 nm to 1700 nm range
- 320 × 256 pixels with EIA(60 Hz) or CCIR(50 Hz)
- The standard USB 2.0 I/F for 14 bit Image acquisition with exposure control
- Small size, light weight and simple operation

### APPLICATIONS

#### ● Si wafer internal inspection

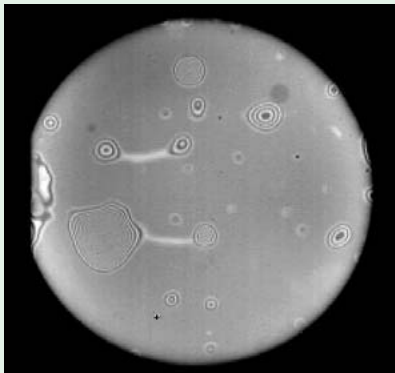

▲ Void detection of bonded wafers

#### ● Solar cell evaluation

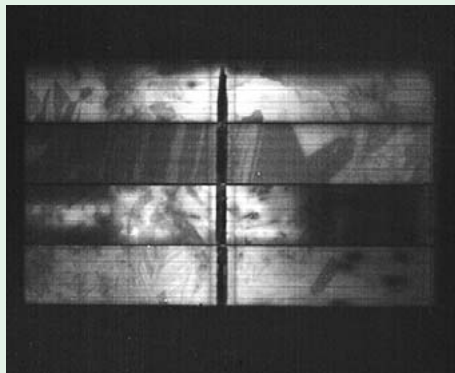

▲ EL(electroluminescence) image of polycrystalline Si PV module

#### ● Laser beam measurement

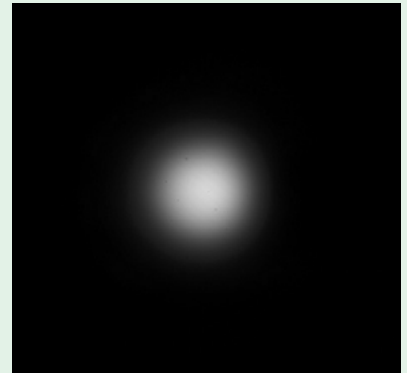

▲ 1.55  $\mu\text{m}$  semiconductor laser beam image  
\* Interference fringe pattern may appear depending on laser beam wavelength and coherency.

#### ● IR reflectography



▲ Observation by visible light (Normal camera)  
The letter under lacquer is invisible.



▲ Observation by IR light (C10633-13)  
The letter under lacquer is clearly visible.

## SYSTEM CONFIGURATION

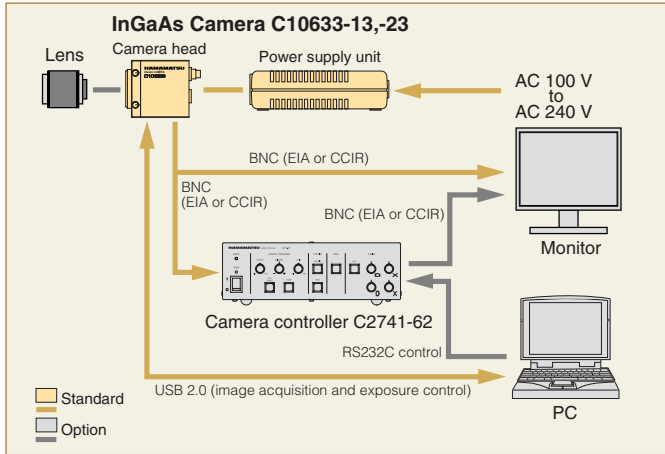

## SPECIFICATIONS

Type number	C10633-13	C10633-23
-------------	-----------	-----------

### ● Array specifications

Array type	InGaAs
Spectral band	900 nm to 1700 nm
Pixels	320 (H) × 256 (V)
Pixels pitch	30 μm
Optical fill factor	> 99.9 %
Array cooling	Uncooled
Pixel operability	> 99 %

### ● Camera specifications

Lens mount	C-mount	
Analog interface (Factory setting)	EIA	CCIR
Digital interface	USB 2.0	
Trigger interface	NA	
Readout speed (full frame)	60 frame/s	50 frame/s
Exposure time	100 μs up to 15 ms (controlled via USB 2.0)	
Power requirements	AC 100 V to AC 240 V, 50 Hz/60 Hz	
Power consumption	4 V·A or less	
Recommended ambient operating temperature	+25 °C ±3 °C *	
Ambient operating temperature	0 °C to +30 °C	
Ambient storage temperature	-10 °C to +60 °C	
Storage/operating humidity	Non-condensing	

\* Correction data acquisition at +25 °C

## DIMENSIONAL OUTLINES (Unit : mm)

### ● Camera head (Approx. 225 g)

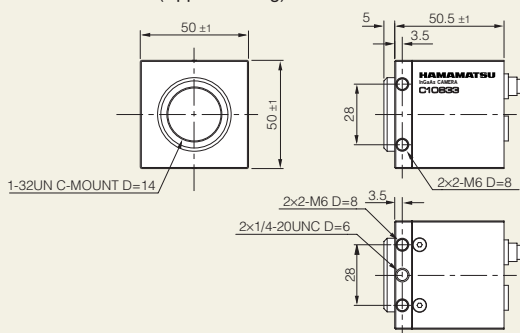

### ● Power supply (Approx. 300 g)

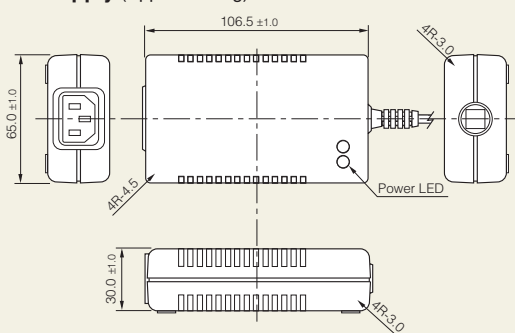

### ★ Product and software package names noted in this documentation are trademarks or registered trademarks of their respective manufacturers.

- Subject to local technical requirements and regulations, availability of products included in this promotional material may vary. Please consult your local sales representative.
- Information furnished by HAMAMATSU is believed to be reliable. However, no responsibility is assumed for possible inaccuracies or omissions.

Specifications and external appearance are subject to change without notice.

© 2010 Hamamatsu Photonics K.K.

# HAMAMATSU

<http://www.hamamatsu.com>

HAMAMATSU PHOTONICS K.K., Systems Division

812 Joko-cho, Higashi-ku, Hamamatsu City, 431-3196, Japan, Telephone: (81)53-431-0124, Fax: (81)53-435-1574, E-mail: [export@sys.hpk.co.jp](mailto:export@sys.hpk.co.jp)

U.S.A. and Canada: Hamamatsu Corporation: 360 Foothill Road, Bridgewater, N.J. 08807-0910, U.S.A., Telephone: (1) 908-231-0960, Fax: (1) 908-231-0852, E-mail: [usa@hamamatsu.com](mailto:usa@hamamatsu.com)

Germany: Hamamatsu Photonics Deutschland GmbH: Arzbergerstr. 10, D-82211 Herrsching am Ammersee, Germany, Telephone: (49)8152-375-0, Fax: (49)8152-2658, E-mail: [info@hamamatsu.de](mailto:info@hamamatsu.de)

France: Hamamatsu Photonics France S.A.R.L.: 19, Rue du Saule Trappu, Parc du Moulin de Massy, 91882 Massy Cedex, France, Telephone: (33)1 69 53 71 00, Fax: (33)1 69 53 71 10, E-mail: [infos@hamamatsu.fr](mailto:infos@hamamatsu.fr)

United Kingdom: Hamamatsu Photonics UK Limited: 2 Howard Court, 10 Tewin Road, Welwyn Garden City, Hertfordshire, AL7 1BW, U.K., Telephone: (44) 1707-294888, Fax: (44) 1707-325777, E-mail: [info@hamamatsu.co.uk](mailto:info@hamamatsu.co.uk)

North Europe: Hamamatsu Photonics Norden AB: Smidesvägen 12, SE-171-41 Solna, Sweden, Telephone: (46)8-509-031-00, Fax: (46)8-509-031-01, E-mail: [info@hamamatsu.se](mailto:info@hamamatsu.se)

Italy: Hamamatsu Photonics Italia S.R.L.: Strada della Moia, 1int.6-20020 Arese (Milano), Italy, Telephone: (39)02-935 81 733, Fax: (39)02-935 81 741, E-mail: [info@hamamatsu.it](mailto:info@hamamatsu.it)

Cat. No. SCAS0056E03  
DEC/2010 HPK  
Created in Japan

## OPTION

### ● Camera controller C2741-62



- Contrast enhancement
- Automatic contrast enhancement
- Shading correction
- Averaging
- Edge extraction
- Y correction

The C2741-62 is a stand alone video image processor used with the C10633 InGaAs camera. It providing exceptional functions such as contrast enhancement, detail enhancement, averaging and shading corrections.



▲ Before contrast enhancement

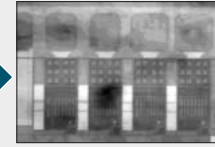

▲ After contrast enhancement

## SPECTRAL RESPONSE

