

Description

The AL8400 is a 5-terminal adjustable Linear LED driver controller offering excellent temperature stability and output handling capability. The AL8400 simplifies the design of linear and isolated LED drivers. With its low 0.2V FB pin, it controls the regulation of LED current with minimal power dissipation when compared to traditional linear LED drivers. This makes it ideal for medium to high current LED driving.

The AL8400 open-collector output can operate from 0.2V to 18V enabling it to drive external MOSFET and Bipolar transistors. This enables the MOSFET and Bipolar selection to be optimised for the chosen application. It also provides the capability to drive longer LED chains, by tapping V_{CC} from the chain, where the chain voltage may exceed 18V.

It is available in the space saving low profile SOT353 package.

Features

- Low reference voltage ($V_{FB} = 0.2V$)
- -40 to 125°C temperature range
- 3% Reference voltage tolerance at 25°C
- Low temperature drift
- 0.2V to 18V open-collector output
- High power supply rejection
- (> 45dB at 300kHz)

Pin Assignments

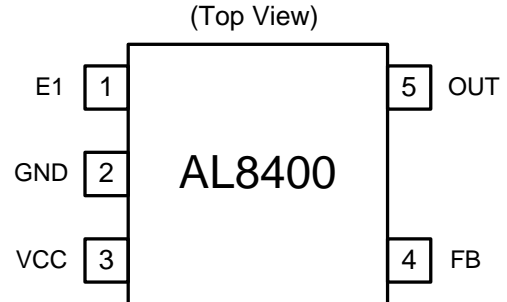

Applications

- Isolated offline LED converters
- Linear LED driver
- LED signs
- Instrumentation illumination

Typical Application Circuit

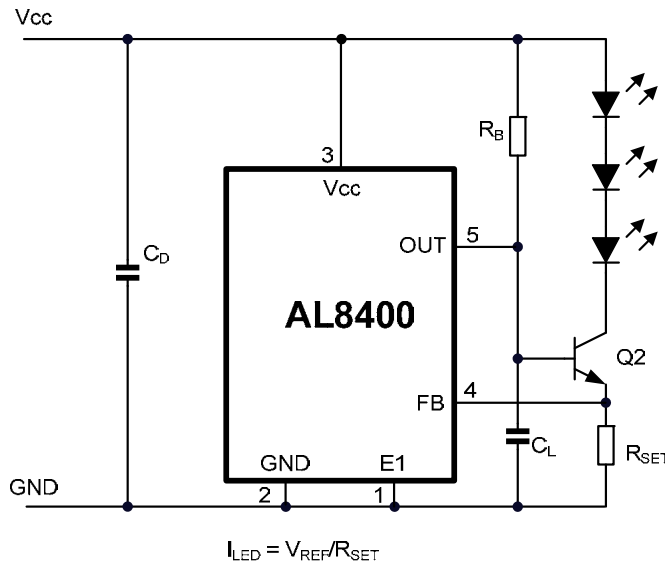

Functional Block Diagram

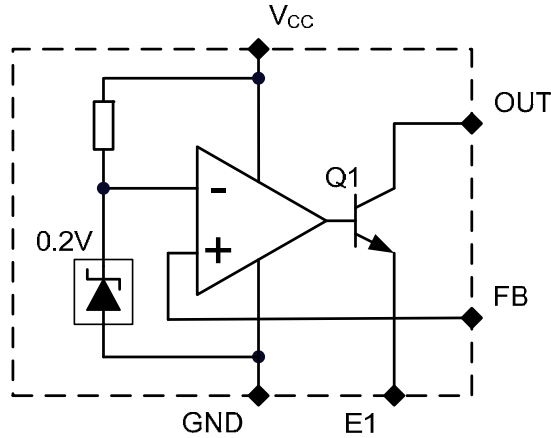

Figure 1. Block Diagram

Pin Descriptions

Pin Number	Name	Function
1	E1	Emitter connection. Connect to GND.
2	GND	Analog Ground. Ground return for reference and amplifier. Connect to E1.
3	V _{CC}	Supply Input. Connect a 0.47μF ceramic capacitor close to the device from VCC to GND.
4	FB	Feedback Input. Regulates to 200mV nominal.
5	OUT	Output. Connect a capacitor close to device between OUT and GND. See the <i>Applications Information</i> section.

Absolute Maximum Ratings

Symbol	Characteristics	Values	Unit
V _{CC}	Supply voltage relative to GND	20	V
V _{OUT}	OUT voltage relative to GND	20	V
V _{FB}	FB voltage relative to GND	20	V
V _{E1}	E1 voltage relative to GND	-0.3 to +0.3	V
T _J	Operating junction temperature	-40 to 150	°C
T _{ST}	Storage temperature	-55 to 150	°C

These are stress ratings only. Operation outside the absolute maximum ratings may cause device failure. Operation at the absolute maximum rating for extended periods may reduce device reliability.

Package Thermal Data

Package	θ _{JA}	P _{DIS} T _A = 25°C, T _J = 150°C
SOT353	400°C/W	310mW

Recommended Operating Conditions

Symbol	Parameter	Min	Max	Units
V _{CC}	Supply voltage range (-40 to 125°C)	2.2	18	V
V _{OUT}	OUT voltage range	0.2	18	
I _{OUT}	OUT pin current	0.3	15	mA
T _A	Operating ambient temperature range	-40	125	°C

Electrical Characteristics (T_A = 25°C, V_{DD} = 3V; unless otherwise specified)

Operating conditions: T_A = 25°C, V_{CC} = 12V, V_{OUT} = V_{FB}, I_{OUT} = 1mA unless otherwise stated (Note 1).

Symbol	Parameter	Conditions	Min.	Typ.	Max.	Units	
V _{FB}	Feedback voltage	T _A = 25°C	0.194	0.2	0.206	V	
		T _A = -40 to 125°C	0.190		0.210		
FB _{LOAD}	Feedback pin load regulation	I _{OUT} = 1 to 15mA	T _A = 25°C		3.1	6	mV
			T _A = -40 to 125°C			10	
FB _{LINE}	Feedback pin line regulation	V _{CC} = 2.2V to 18V	T _A = 25°C		0.1	1.5	mV
			T _A = -40 to 125°C			2	
FB _{OV}	Output voltage regulation	V _{OUT} = 0.2V to 18V, I _{OUT} = 1mA (Ref. Figure 1)	T _A = 25°C			2	mV
			T _A = -40 to 125°C			3	
I _{FB}	FB input bias current	V _{CC} = 18V	T _A = 25°C		-45		nA
			T _A = -40 to 125°C	-200		0	
I _{CC}	Supply current	V _{CC} = 2.2V to 18V, I _{OUT} = 10mA	T _A = 25°C		0.48	1	mA
			T _A = -40 to 125°C			1.5	
I _{OUT(LK)}	OUT leakage current	V _{CC} = 18V, V _{OUT} = 18V, V _{FB} = 0V	T _A = 25°C			0.1	µA
			T _A = 125°C			1	
Z _{OUT}	Dynamic Output Impedance	I _{OUT} = 1 to 15mA f < 1kHz	T _A = 25°C		0.25	0.4	Ω
			T _A = -40 to 125°C			0.6	
PSRR	Power supply rejection ratio	f = 300kHz, V _{AC} = 0.3V _{PP}	T _A = 25°C		45		dB
BW	Amplifier Unity Gain Frequency		T _A = 25°C		600		kHz
G	Amplifier Transconductance		T _A = 25°C		4500		mA/V

Note: 1. Production testing of the device is performed at 25 °C. Functional operation of the device and parameters specified over the operating temperature range are guaranteed by design, characterisation and process control.

Typical Characteristics

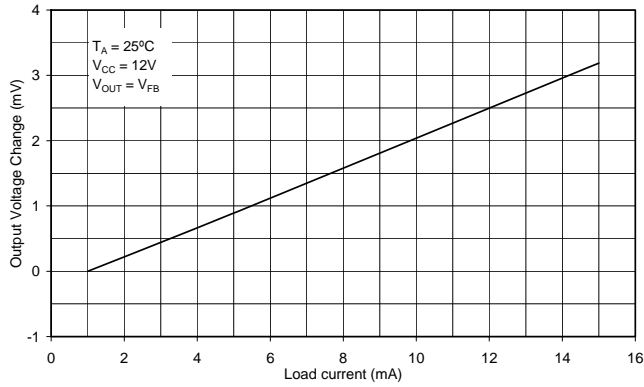

Load regulation

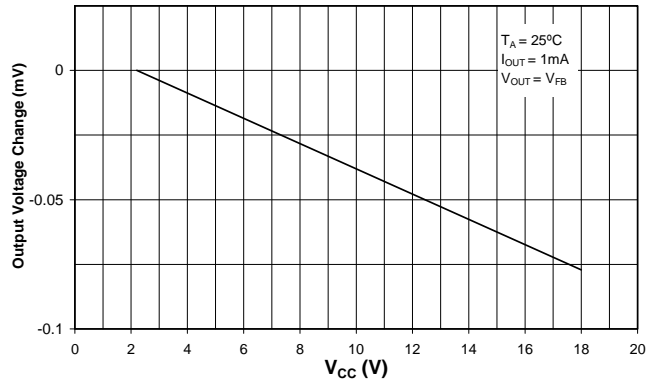

Line regulation

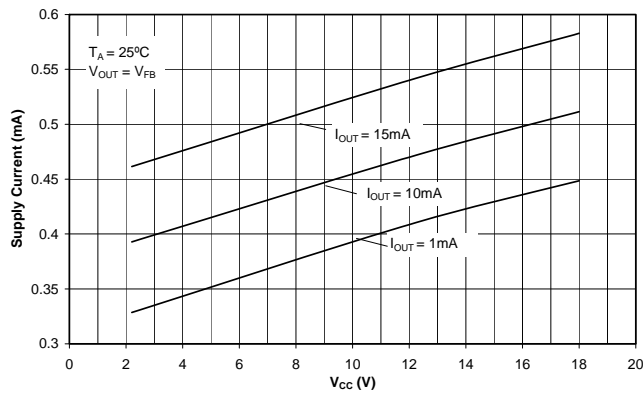

Supply current with input voltage

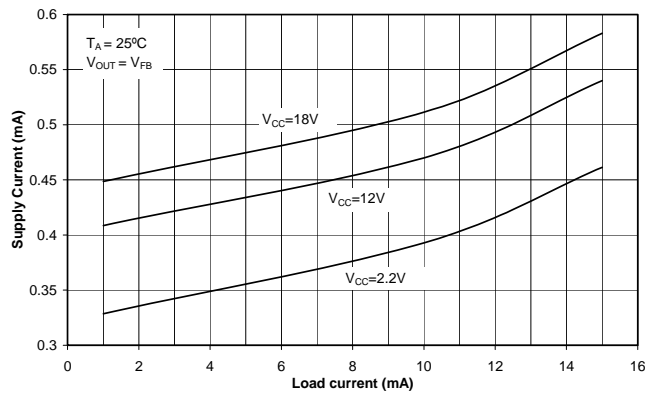

Supply current with load current

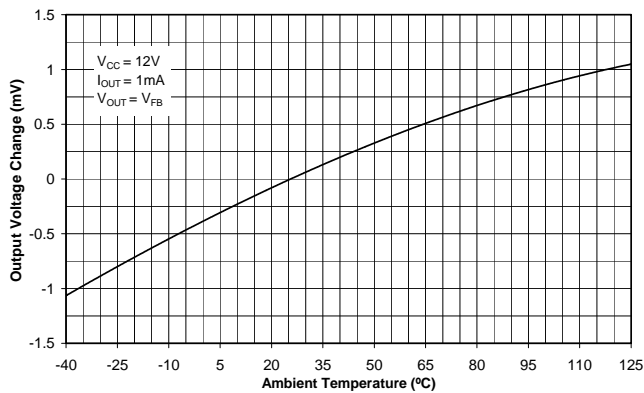

OUT voltage change with Temperature

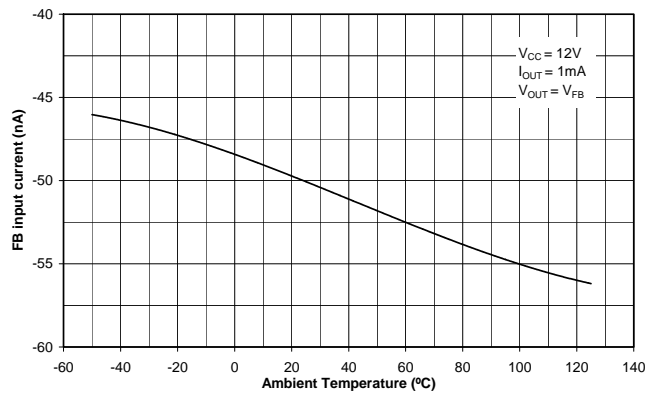

FB input current with Temperature

Typical Characteristics (Continued)

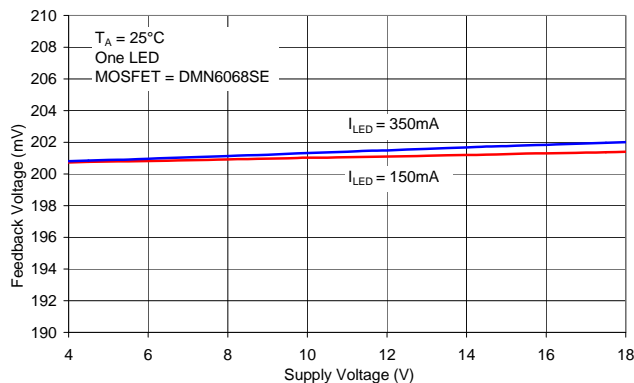

MOSFET driving

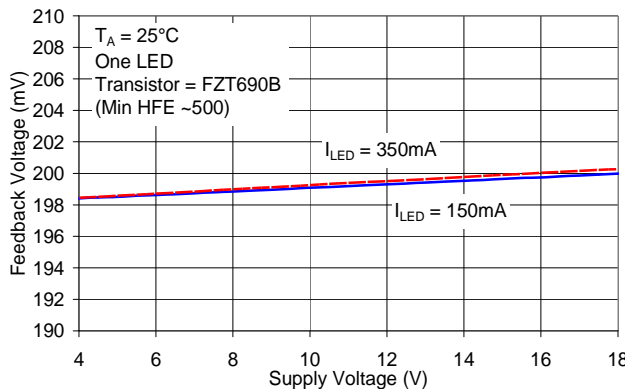

Bipolar transistor driving

Application Information

Description

The AL8400 uses its FB pin to sense the LED current through an external resistor R_{SET} . An external pass element consists of an NPN transistor or N-channel MOSFET. The pass element is used to regulate the LED's current and is driven from the AL8400's open collector OUT pin. An external resistor, R_B , is required to be connected from the OUT pin to V_{CC} . This resistor supplies the output bias current of the AL8400 together with any current which the pass element requires.

Bipolar transistor as the pass element

For driving at currents in the region of about 50mA to about 400mA, the recommended NPN is DNLS320E in the SOT223 package. The high DC current gain of the DNLS320E is useful in this application, in order to minimise the current in R_B . The design procedure is as follows, referring to Figure 2.

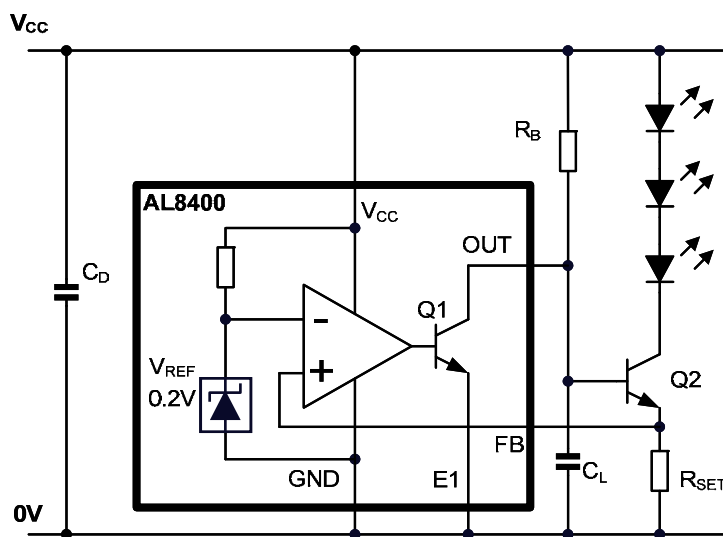

Figure 2. Application Circuit Using Bipolar Transistor

Application Information (Continued)

Bipolar transistor as the pass element (Continued)

There are two important equations for the circuit:

LED circuit path:

$$1 \dots V_{CC} = (V_{LED} + V_{CE} + V_{REF})$$

Control drive circuit path

$$2 \dots V_{CC} = (V_{RB} + V_{BE} + V_{REF})$$

The maximum total LED voltage plus the reference voltage determines the minimum supply voltage. Substituting into equation 1 yields:

$$V_{CCmin} = V_{LED} + V_{CEsat} + V_{REF}$$

For a bipolar transistor the voltage (V_{RB}) across bias resistor R_B consists of the base current of Q2 and the output current of the AL8400. So rearranging equation 2 yields the boundaries for allowable R_B values:

$$R_{Bmax} = \frac{V_{CCmin} - V_{BEmax} - V_{REF}}{I_{OUTmin} + I_{Bmax}}$$

$$R_{Bmin} = \frac{V_{CCmax} - V_{BEmin} - V_{REF}}{I_{OUTmax} + I_{Bmin}}$$

where I_{Bmax} is the maximum transistor base current

where I_{Bmin} is the minimum transistor base current

$$I_{Bmax} = \frac{I_{LED}}{h_{FEmin}} \text{ where } h_{FEmin} \text{ is the minimum DC}$$

$$I_{Bmin} = \frac{I_{LED}}{h_{FEmax}} \text{ where } h_{FEmax} \text{ is the maximum DC current gain of}$$

current gain of the transistor.

the transistor.

Finally, the bipolar selection is also influenced by the maximum power dissipation

$$P_{TOT} = I_{LED} * (V_{CC} - V_{LED} - V_{REF}) = I_{LED} * V_{CE}$$

Since this determines the package choice (θ_{JA}) in order to keep the junction temperature below the maximum value allowed.

$$T_J = T_A + P_{TOT} * \theta_{JA}$$

Bipolar Example

The driver is required to control 2 series connected LEDs at 150mA \pm 10%, each having a forward voltage of 3V minimum and 3.6V maximum. Hence the minimum operating supply voltage is $3.6 * 2 + 0.2 = 7.4V$. The actual supply voltage given is 8V \pm 5%, i.e. 7.6V minimum. We will use the DNLS320E bipolar transistor (Q2).

The DNLS320E datasheet shows:

$$h_{FEmin} \text{ is } 500 @ I_C = 100mA, 400 @ I_C = 2A,$$

The datasheet graph shows a very slow variation at his current, so a value of 500 is appropriate.

$$\text{Then } I_{Bmax} = \frac{150}{500} = 0.3mA$$

The minimum recommended I_{OUT} for AL8400 is 0.3mA and the maximum V_{BE} , according to the DNLS320E datasheet graph, is approximately 0.8V at -55°C.

From these the maximum allowed bias resistor value is:

$$R_{Bmax} = \frac{7.6 - 0.8 - 0.2}{0.0003 + 0.0003} = 11k\Omega$$

To ensure that the output capability of the AL8400 is not exceeded at maximum V_{IN} , maximum h_{FE} and minimum V_{BE} , these values should be substituted back into the R_B equation to determine the minimum allowable value for R_B .

h_{FEmax} is about 1200 @ $I_C = 100mA$, and a temperature of 85°C which results in:

$$I_{Bmin} = \frac{150}{1200} = 0.125mA$$

Application Information (Continued)

Bipolar Example (Continued)

The maximum recommended I_{OUT} for AL8400 is 15mA.

The minimum V_{BE} , according to the DNLS320E datasheet graph, is approximately 0.4V at 85°C and assuming $V_{CCmax} = 8.4V$, then the bias resistor value is:

$$R_{Bmin} = \frac{8.4 - 0.4 - 0.2}{0.015 + 0.000125} = 516\Omega \quad \text{This is less than } 11k\Omega \text{ and so the AL8400 output current is within its ratings.}$$

The value of R_{SET} is V_{REF}/I_{LED} so:

$$R_{SET} = 0.2/0.15 = 1.333\Omega \rightarrow 1.3\Omega \text{ is practical.}$$

Finally, the maximum power dissipation of the external bipolar transistor is:

$$P_{TOT} = I_{LED} * V_{CEMAX} \\ = I_{LED} * (V_{CC} - V_{LED_MIN} - V_{REF}) = 0.27W$$

This determines the package choice (θ_{JA}) in order to keep the junction temperature of the bipolar below the maximum value allowed.

$$T_J = T_A + P_{TOT} * \theta_{JA} \\ = T_A + 0.27 * 125 = T_A + 33.75^\circ C$$

N-channel MOSFET as the pass element

Alternatively, an N-channel MOSFET may be used in the same configuration. The current in R_B is then reduced compared to the case in which the bipolar transistor is used. For LED currents up to about 400mA a suitable MOSFET is DMN6068SE in the SOT223 package. The design procedure is as follows, referring to Figure 3.

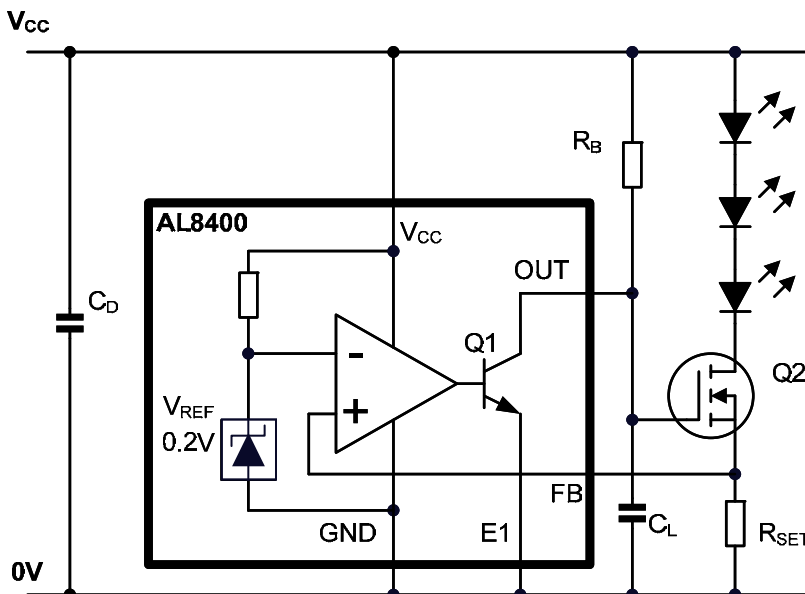

Figure 3. Application Circuit Using MOSFET

The equations (1 and 2) for the bipolar transistor are transformed into:

LED circuit path:

$$1.....V_{CC} = (V_{LED} + V_{DS} + V_{REF})$$

Control drive circuit path

$$2.....V_{CC} = (V_{RB} + V_{GS} + V_{REF})$$

Application Information (Continued)

N-channel MOSFET as the pass element (Continued)

The maximum total LED voltage plus the reference voltage determines the minimum supply voltage. Substituting into equation 3 yields:

$$V_{CCmin} = V_{LED} + V_{DSMIN} + V_{REF}$$

The MOSFET DC gate current is negligible, so the bias resistor R_B has only to provide the minimum output current of the AL8400. So rearranging equation 4 yields the boundaries for allowable R_B values:

$$R_{Bmin} = \frac{V_{CCmax} - V_{GSmin} - V_{REF}}{I_{OUTmax}}$$

$$R_{Bmax} = \frac{V_{CCmin} - V_{GSmax} - V_{REF}}{I_{OUTmin}}$$

Where I_{OUTmax} is the AL8400 maximum output current

Where I_{OUTmin} is the AL8400 minimum output current

Note that in the case of a single LED, the MOSFET gate-source voltage may be too high for operation over the desired supply voltage range. If the gate source voltage at the operating current is V_{GSmax} , we must have:

$$V_{RBmin} + V_{GSmax} + V_{REF} < V_{CC} \text{ Where } V_{RBmin} \text{ is the minimum voltage drop across } R_B.$$

V_{RBmin} is determined by the operating voltage range. At the top of the range, the current is required to be not greater than 15mA.

The supply voltage is usually the LED voltage plus a margin for transistor saturation voltage, plus V_{REF} . The bias amounts to the voltage across R_B plus V_{REF} (0.2V). Therefore the use of the MOSFET may not be practical for driving a single LED if the V_{GS} is too high. Then either a MOSFET with lower V_{GS} must be selected, or a bipolar NPN device must be used.

Finally, the MOSFET selection is also influenced by the maximum power dissipation

$$P_{TOT} = I_{LED} * (V_{CC} - V_{LED} - V_{REF}) = I_{LED} * V_{DS}$$

Since this determines the package choice (θ_{JA}) in order to keep the junction temperature below the maximum value allowed.

$$T_J = T_A + P_{TOT} * \theta_{JA}$$

MOSFET Example

The driver is required to control 2 series connected LEDs at 150mA $\pm 10\%$, each having a forward voltage of 3V minimum and of 3.6V maximum. Hence the minimum operating supply voltage is $3.6 * 2 + 0.2 = 7.4V$. The actual supply voltage given is 8V $\pm 5\%$, i.e. 7.6V minimum. We will use the DMN6068SE N-channel MOSFET (Q2),

The minimum recommended I_{out} for AL8400 is 0.3mA.

The maximum V_{GS} is not stated explicitly, but from the datasheet graphs it is expected to be approximately 3.8V at $-50^\circ C$. (Here we have used the graphs of Typical Transfer and Normalised VGS(th) versus temperature.)

$$\text{So } R_{Bmax} = (7.6 - 3.8 - 0.2) / 0.0003 = 12k\Omega$$

To ensure that the output capability of the AL8400 is not exceeded at maximum V_{IN} and minimum V_{GS} these values should be substituted back into the R_B equation to determine the minimum allowable value for R_B .

The maximum recommended I_{OUT} for the AL8805 is 15mA. The minimum V_{GS} is about 1V, and assuming $V_{CCmax} = 8.4V$:

$$R_{Bmin} = \frac{8.4 - 1 - 0.2}{0.015} = 480\Omega \quad \text{This is less than } 12k\Omega \text{ and so the AL8400 output current is within its ratings.}$$

The value of R_{SET} is V_{REF}/I_{LED}

$$R_{SET} = 0.2/0.15 = 1.333\Omega \rightarrow 1.3\Omega \text{ is practical.}$$

Application Information (Continued)

MOSFET Example (Continued)

Finally, the maximum power dissipation of the external MOSFET is:

$$P_{TOT} = I_{LED} * V_{DSMAX}$$

$$= I_{LED} * (V_{CC} - V_{LEDMIN} - V_{REF}) = 0.27W$$

This determines the package choice (θ_{JA}) in order to keep the junction temperature below the maximum value allowed.

$$T_J = T_A + P_{TOT} * \theta_{JA}$$

$$= T_A + 0.27 * 62.5 = T_A + 16.86^\circ C$$

Stability

In order to maintain the stability of the current control loop, a capacitor, C_L , is required to be connected from the OUT pin to Ground. The value is determined by the minimum time constant, $C_L R_B \geq 1ms$. For example if $R_B = 10k\Omega$, then C_L must be 0.1 μF or greater. The capacitor type is recommended to be X7R ceramic.

For best stability a power supply decoupling capacitor, C_D is recommended, 0.1 μF minimum, X7R ceramic, connected between V_{CC} and Ground.

OFFLINE LED LAMPS

The configuration of the AL8400 also makes it suitable for controlling the current of an offline (mains) isolated LED lamp by way of an opto-coupler to drive the feedback pin of the primary-side switching controller.

The current sensing of the LED current is done via R_{SET} but the OUT pin now drives the cathode of the diode in the opto-coupler. See Figure 4 below.

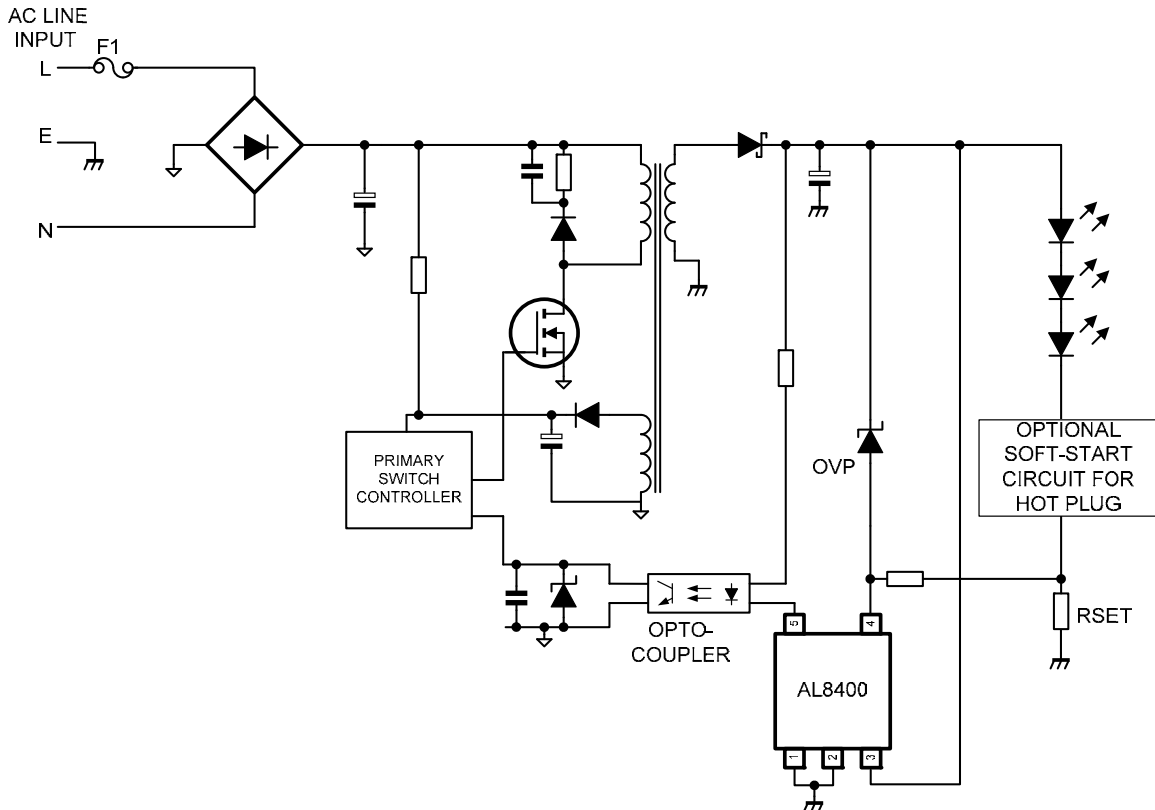

Figure 4. Off-line LED Drive Application of AL8400

Application Information (Continued)

High voltage operation

The AL8400 also provides the capability to drive longer LED chains as the voltage across the LED chain is determined by the external switch. The lower supply voltage for the AL8400 can be derived from the supply to the LED chain either by putting a series resistor to the AL8400's V_{CC} pin and putting a suitable zener diode from its V_{CC} to GND Figure 5 or by tapping its V_{CC} from the LED chain Figure 6.

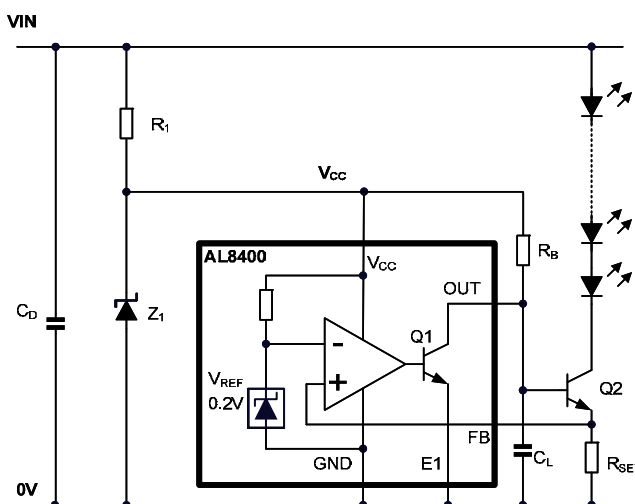

Figure 5. High voltage operation with zener diode from VIN

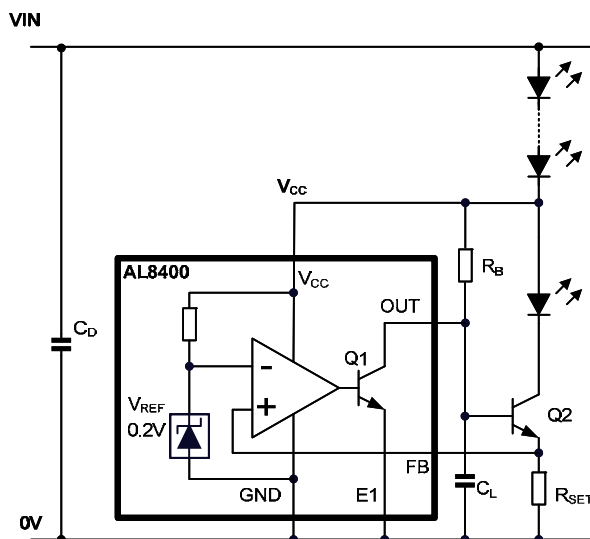

Figure 6. High voltage operation tapping V_{CC} from the LED string

When the supply voltage for the AL8400 is derived using a zener diode, care has to be taken in dimensioning the resistor R1. The current spilled from V_{IN} has to be enough to polarize the zener and to supply the LED driver. On the other hand, when the supply voltage for the AL8400 is derived from the LED string, care has to be taken in dimensioning the resistor R_B . The current spilled from the LED chain can reduce the accuracy of the system and brightness matching between the LED.

Ordering Information

Device	Package Code	Packaging (Note 3)	7" Tape and Reel	
			Quantity	Part Number Suffix
AL8400SE-7	SE	SOT353	3000/Tape & Reel	-7

- Notes: 2. EU Directive 2002/95/EC (RoHS). All applicable RoHS exemptions applied. Please visit our website at http://www.diodes.com/products/lead_free.html
3. Pad layout as shown on Diodes Inc. suggested pad layout document AP02001, which can be found on our website at <http://www.diodes.com/datasheets/ap02001.pdf>.

Marking Information

(1) SOT353

(Top View)

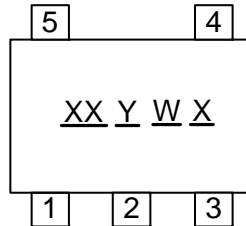

- XX : Identification code
- Y : Year 0~9
- W : Week : A~Z : 1~26 week;
a~z : 27~52 week; z represents 52 and 53 week
- X : A~Z : Green

Part Number	Package	Identification Code
AL8400SE-7	SOT353	B4

Package Outline Dimensions (All Dimensions in mm)

(1) Package Type: SOT353

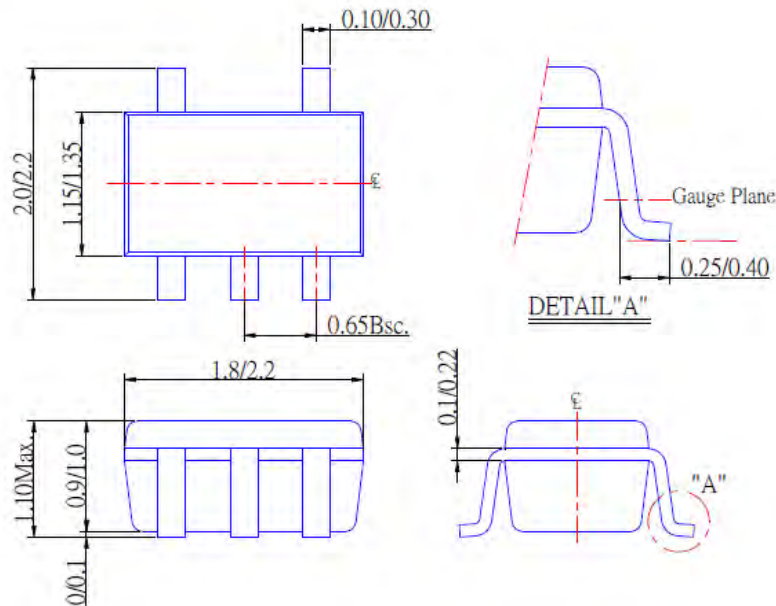

IMPORTANT NOTICE

DIODES INCORPORATED MAKES NO WARRANTY OF ANY KIND, EXPRESS OR IMPLIED, WITH REGARDS TO THIS DOCUMENT, INCLUDING, BUT NOT LIMITED TO, THE IMPLIED WARRANTIES OF MERCHANTABILITY AND FITNESS FOR A PARTICULAR PURPOSE (AND THEIR EQUIVALENTS UNDER THE LAWS OF ANY JURISDICTION).

Diodes Incorporated and its subsidiaries reserve the right to make modifications, enhancements, improvements, corrections or other changes without further notice to this document and any product described herein. Diodes Incorporated does not assume any liability arising out of the application or use of this document or any product described herein; neither does Diodes Incorporated convey any license under its patent or trademark rights, nor the rights of others. Any Customer or user of this document or products described herein in such applications shall assume all risks of such use and will agree to hold Diodes Incorporated and all the companies whose products are represented on Diodes Incorporated website, harmless against all damages.

Diodes Incorporated does not warrant or accept any liability whatsoever in respect of any products purchased through unauthorized sales channel.

Should Customers purchase or use Diodes Incorporated products for any unintended or unauthorized application, Customers shall indemnify and hold Diodes Incorporated and its representatives harmless against all claims, damages, expenses, and attorney fees arising out of, directly or indirectly, any claim of personal injury or death associated with such unintended or unauthorized application.

Products described herein may be covered by one or more United States, international or foreign patents pending. Product names and markings noted herein may also be covered by one or more United States, international or foreign trademarks.

LIFE SUPPORT

Diodes Incorporated products are specifically not authorized for use as critical components in life support devices or systems without the express written approval of the Chief Executive Officer of Diodes Incorporated. As used herein:

A. Life support devices or systems are devices or systems which:

1. are intended to implant into the body, or
2. support or sustain life and whose failure to perform when properly used in accordance with instructions for use provided in the labeling can be reasonably expected to result in significant injury to the user.

B. A critical component is any component in a life support device or system whose failure to perform can be reasonably expected to cause the failure of the life support device or to affect its safety or effectiveness.

Customers represent that they have all necessary expertise in the safety and regulatory ramifications of their life support devices or systems, and acknowledge and agree that they are solely responsible for all legal, regulatory and safety-related requirements concerning their products and any use of Diodes Incorporated products in such safety-critical, life support devices or systems, notwithstanding any devices- or systems-related information or support that may be provided by Diodes Incorporated. Further, Customers must fully indemnify Diodes Incorporated and its representatives against any damages arising out of the use of Diodes Incorporated products in such safety-critical, life support devices or systems.

Copyright © 2010, Diodes Incorporated

www.diodes.com