

54, 74 Series GHz Logic

FEATURES:	DESCRIPTION:
<ul style="list-style-type: none"> . Patented technology . Specified From -40°C to 85°C, -40°C to 125°C, and -55°C to 125°C . Operating frequency up to 1.125GHz with 2pf load . Operating frequency up to 700MHz with 5pf load . Operating frequency up to 270MHz with 15pf load . VCC Operates from 1.65V to 3.6V . Propagation delay < 1.4ns max with 15pf load . Low input capacitance: 4pf typical . Latch-Up Performance Exceeds 250 mA Per JESD 17 . ESD Protection Exceeds JESD 22 . 5000-VHuman-BodyModel (A114-A) . 200-VMachineModel (A115-A) . Available in 14pin 150mil wide SOIC package . Available in 14pin Ceramic Dual Flatpack . Available in 20pin Leadless Ceramic Chip Carrier 	<p>Potato Semiconductor's PO74G04A is designed for world top performance using submicron CMOS technology to achieve 1.125GHz TTL /CMOS output frequency with less than 1.4ns propagation delay.</p> <p>This hex inverter contains six independent inverters designed for 1.65-V to 3.6-V VCC operation.</p> <p>The PO74G04A performs the Boolean function $Y = \overline{A}$.</p> <p>Inputs can be driven from either 3.3V or 5V devices. This feature allows the use of these devices as translators in a mixed 3.3V/5V system environment.</p>

Pin Configuration

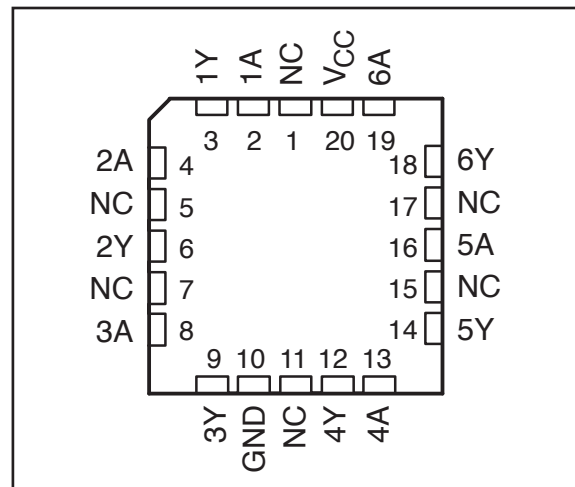
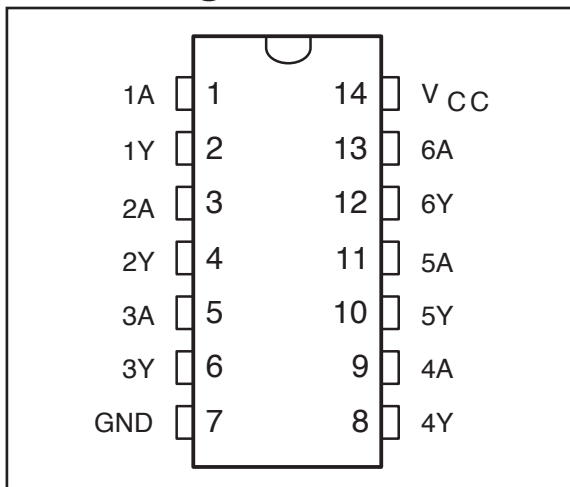

Pin Description

INPUT A	OUTPUT Y
H	L
L	H

Logic Block Diagram

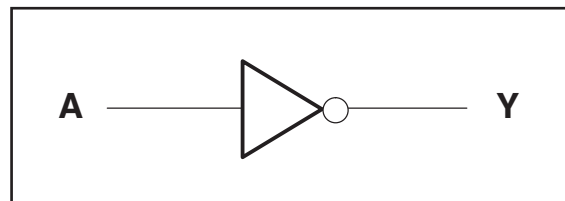

54, 74 Series GHz Logic

Maximum Ratings

Description	Max	Unit
Storage Temperature	-65 to 150	°C
Operation Temperature	-55 to 125	°C
Operation Voltage	-0.5 to +4.6	V
Input Voltage	-0.5 to +5.5	V
Output Voltage	-0.5 to V _{cc} +0.5	V

Note:

stresses greater than listed under Maximum Ratings may cause permanent damage to the device. This is a stress rating only and functional operation of the device at these or any other conditions above those indicated in the operational sections of this specification is not implied. Exposure to absolute maximum rating conditions for extended periods may affect reliability specification is not implied.

DC Electrical Characteristics

Symbol	Description	Test Conditions	Min	Typ	Max	Unit
V_{OH}	Output High voltage	V _{cc} =3V Vin=V _{IH} or V _{IL} , I _{OH} = -12mA	2.4	3	-	V
V_{OL}	Output Low voltage	V _{cc} =3V Vin=V _{IH} or V _{IL} , I _{OH} =12mA	-	0.3	0.5	V
V_{IH}	Input High voltage	Guaranteed Logic HIGH Level (Input Pin)	2	-	5.5	V
V_{IL}	Input Low voltage	Guaranteed Logic LOW Level (Input Pin)	-0.5	-	0.8	V
I_{IH}	Input High current	V _{cc} = 3.6V and Vin = 5.5V	-	-	5	uA
I_{IL}	Input Low current	V _{cc} = 3.6V and Vin = 0V	-	-	-5	uA
V_{IK}	Clamp diode voltage	V _{cc} = Min. And I _{IN} = -18mA	-	-0.7	-1.2	V

Notes:

1. For conditions shown as Max. or Min., use appropriate value specified under Electrical Characteristics for the applicable device type.
2. Typical values are at V_{cc} = 3.3V, 25 °C ambient.
3. This parameter is guaranteed but not tested.
4. Not more than one output should be shorted at one time. Duration of the test should not exceed one second.
5. V_{OH} = V_{cc} - 0.6V at rated current

54, 74 Series GHz Logic

Power Supply Characteristics

Symbol	Description	Test Conditions (1)	Min	Typ	Max	Unit
IccQ	Quiescent Power Supply Current	Vcc=Max, Vin=Vcc or GND	-	0.1	40	uA

Notes:

1. For conditions shown as Max. or Min., use appropriate value specified under Electrical Characteristics for the applicable device type.
2. Typical values are at Vcc = 3.3V, 25°C ambient.
3. This parameter is guaranteed but not tested.
4. Not more than one output should be shorted at one time. Duration of the test should not exceed one second.

Capacitance

Parameters (1)	Description	Test Conditions	Typ	Unit
Cin	Input Capacitance	Vin = 0V	4	pF
Cout	Output Capacitance	Vout = 0V	6	pF

Notes:

- 1 This parameter is determined by device characterization but not production tested.

Switching Characteristics

Symbol	Description	Test Conditions (1)	Max	Unit
tPLH	Propagation Delay A, B to Y	CL = 15pF	1.4	ns
tPHL	Propagation Delay A, B to Y	CL = 15pF	1.4	ns
tr/tf	Rise/Fall Time	0.8V – 2.0V	0.8	ns
fmax	Input Frequency	CL = 15pF	270	MHz
fmax	Input Frequency	CL = 5pF	700	MHz
fmax	Input Frequency	CL = 2pF	1125	MHz

Notes:

1. See test circuits and waveforms.
2. tPLH, tPHL, tsk(p), and tsk(o) are production tested. All other parameters guaranteed but not production tested.
3. Airflow of 1m/s is recommended for frequencies above 133MHz

54, 74 Series GHz Logic

Test Waveforms

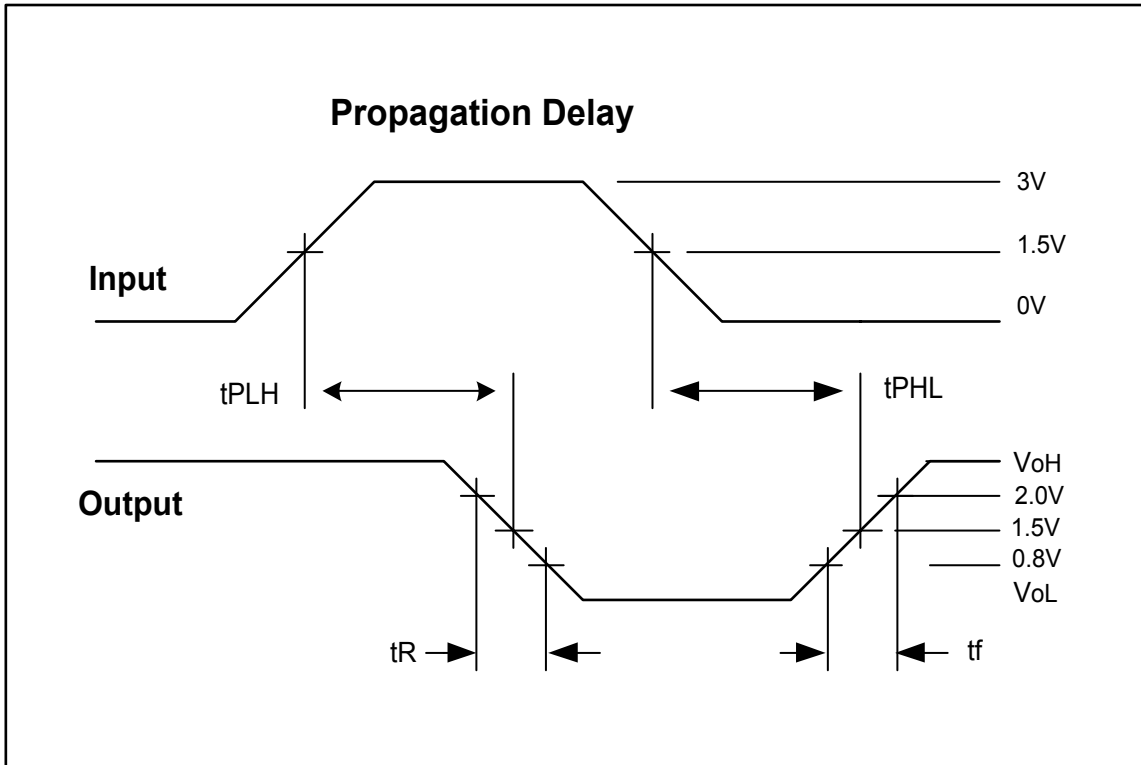

Test Circuit

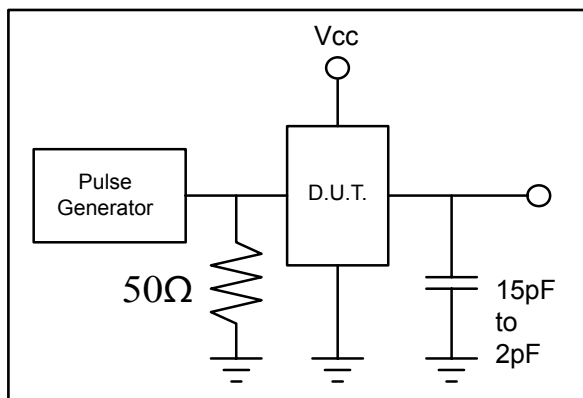

54, 74 Series GHz Logic

Packaging Mechanical Drawing: 14 pin 150mil SOIC

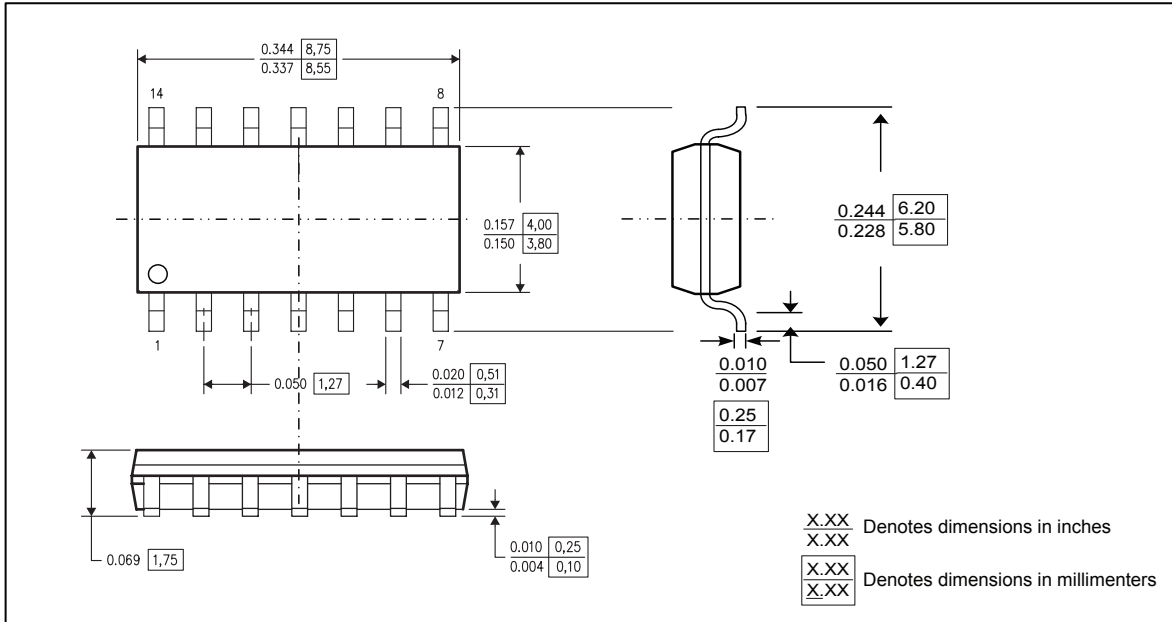

Packaging Mechanical Drawing: 14pin Leadless Ceramic Chip Carrier

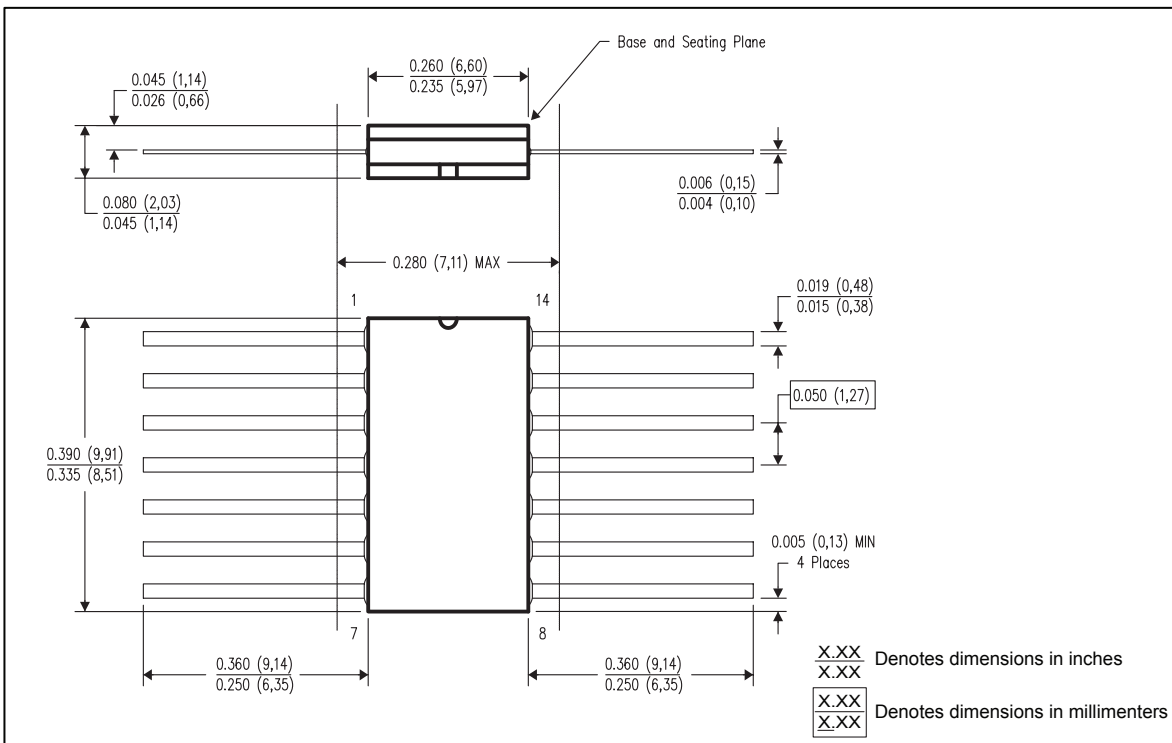

54, 74 Series GHz Logic

Packaging Mechanical Drawing: 20pin Ceramic Dual Flatpack

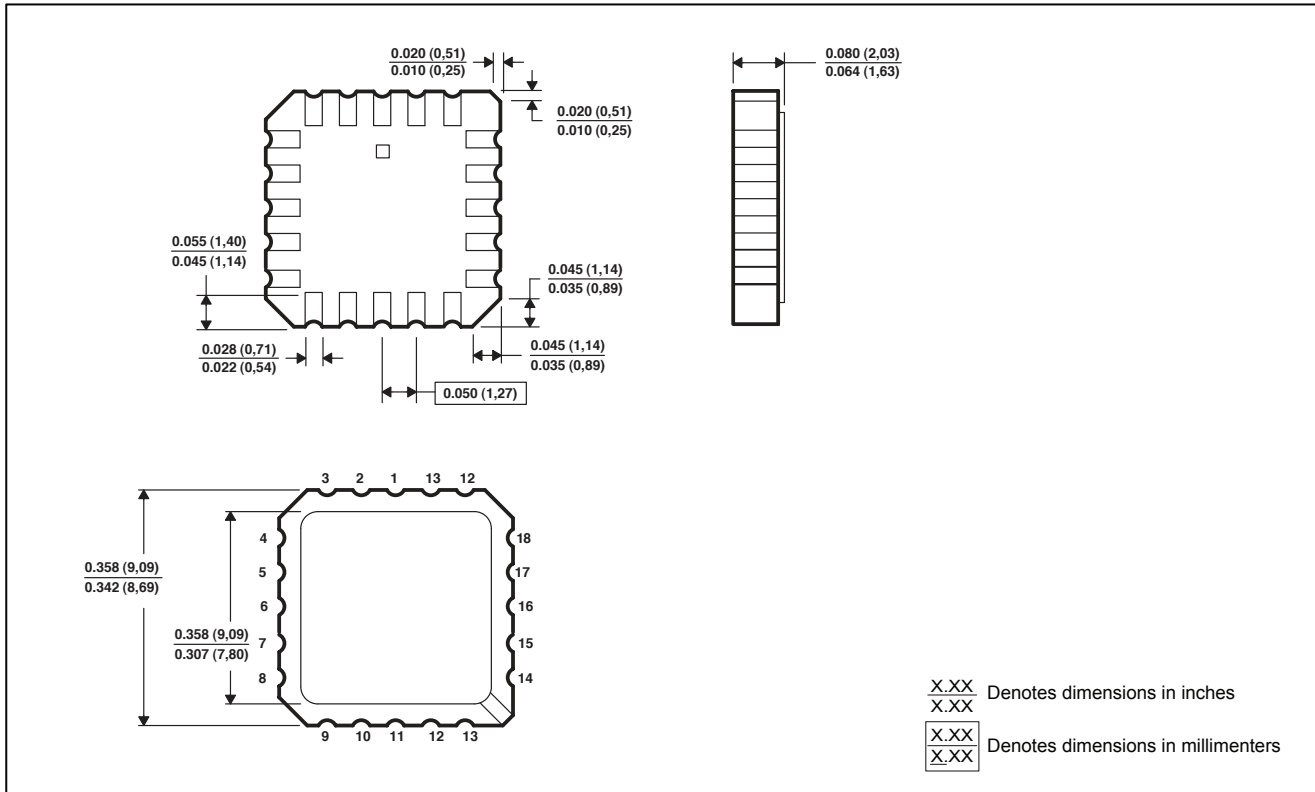

Ordering Information

Ordering Code	Package			Top-Marking	T _A
PO74G04ASU	14pin SOIC	Tube	Pb-free & Green	PO74G04AS	-40°C to 85°C
PO74G04ASR	14pin SOIC	Tape and reel	Pb-free & Green	PO74G04AS	-40°C to 85°C
PO74G04ASiU	14pin SOIC	Tube	Pb-free & Green	PO74G04ASi	-40°C to 125°C
PO74G04ASiR	14pin SOIC	Tape and reel	Pb-free & Green	PO74G04ASi	-40°C to 125°C
PO54G04ALU	14pin Leadless Ceramic Chip Carrier	Tube	Pb-free & Green	PO54G04AL	-55°C to 125°C
PO54G04AFU	20pin Ceramic Dual Flatpack	Tube	Pb-free & Green	PO54G04AF	-55°C to 125°C