

Sensorless Motor Drive Platform with Integrated PFC for Appliance Based on iMOTION™ Chipset

Features

- IRMCF343 - iMOTION™ digital control IC-based system
- MCE™ (Motion Control Engine) - Hardware based computation engine for high efficiency sinusoidal sensorless control of Permanent Magnet motors
- Integrated digital power factor correction (PFC)
- Supports both interior and surface permanent magnet motor sensorless control
- Single shunt current feedback reconstruction
- No external current or voltage sensing OP amp circuit required
- 230V/1700W continuous power with Trench IGBT for PFC and Integrated Power Module for inverter
- Harmonics complying with EN61000-3-2 Class-A
- Loss minimization Space Vector PWM
- Two-channel analog output (PWM)
- Embedded 8-bit high speed microcontroller (8051) for flexible I/O and man-machine control
- JTAG programming port for emulation/debugger
- I²C serial interface to EEPROM
- MCEDesigner™ tool for easy operation
- Flexible drive configuration
- RS232C interface
- Over-current and over-voltage/under-voltage protection
- EMI filter and switch-mode power supply included

Product Summary

Continuous input power	1700W*
Continuous output current	6.0 Arms*
Maximum overload output current	20 Apeak**
Maximum Internal clock (SYSCLK)	128 MHz
Sensorless control computation time	11 µsec typ.
RAM loaded from external EEPROM	48 Kbytes
Data RAM	8 Kbytes
A/D input channels	5
A/D converter resolution	12 bits
A/D converter conversion speed	2 µsec
8051 instruction execution speed	2 SYSCLK
Analog output (PWM) resolution	8 bits
RS232C baud rate (typ.)	57.6 Kbps

* Upgradeable to higher current with larger heat sink

** Changeable by modifying the hardware.

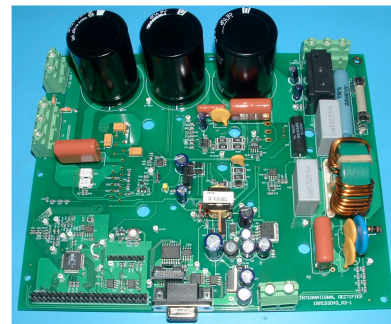

Description

IRMCS3043 is a reference design platform for IRMCF343, a high performance RAM-based motion control IC designed primarily for appliance applications, up to 1.7kW continuous input power. It's mainly aimed to achieve simple, low cost and high performance solutions for advanced appliance motor control. It consists of an active PFC frond-end and an inverter stage, both of which are controlled by the IRMCF343 digital IC simultaneously. The power stage contains a Trench IGBT (IRGP4063DPbF) for the PFC and an integrated power module (IRAMX16UP60A-2) for the inverter, which are part of iMOTION™ chipset. Users can readily evaluate high performance sensorless control with MCEDesigner™ software without spending development effort usually required in the traditional DSP or microcontroller based system. The complete B/Ms, schematics and layout are provided so that the user can adapt and tailor the design per application needs.



Table of Contents

- 1 Introduction 3
 - 1.1 Overview 3
 - 1.2 Safety Precautions 4
 - 1.3 Debris When Unpacking 6
- 2 Hardware Description 7
 - 2.1 PCB 7
 - 2.2 Isolation Boundary 7
 - 2.3 IRMCF343 8
 - 2.3.1 Power 8
 - 2.3.2 Crystal 8
 - 2.3.3 Reset Circuit 8
 - 2.3.4 EEPROM 8
 - 2.3.5 Digital I/O 8
 - 2.3.6 Analog Output 8
 - 2.3.7 Motor Single-Shunt Current Feedback 8
 - 2.3.8 PFC Current Feedback 8
 - 2.3.9 AC Input Voltage Feedback 8
 - 2.3.10 DC Bus Voltage Feedback 8
 - 2.4 Input Diode Bridge Rectifier 8
 - 2.5 PFC IGBT and Diode 9
 - 2.6 PFC Inductor 9
 - 2.7 IRAM 9
 - 2.8 Power Supply 9
 - 2.9 EMI Filter 9
 - 2.10 DC Bus Capacitors 9
- 3 Specifications 10

List of Figures

- Figure 1. IRMCS3043 System Block Diagram 3
- Figure 2. Top View of IRMCS3043 7

List of Tables

- Table 1. IRMCS3043 Electrical Specification 10

1 Introduction

1.1 Overview

IRMCS3043 is a reference design platform for complete inverter-controlled appliance motor drive applications based on iMOTION™ chipset, up to 1.7kW continuous input power. By using the IRMCF343 digital control IC, it provides a one-chip solution that simultaneously controls PFC frond-end circuit and one permanent magnetic (PM) AC motor (sinusoidal back EMF) without requiring motor position sensors.

IRMCF343 is International Rectifier’s new integrated circuit device primarily designed as a one-chip solution for sensorless permanent magnet motor control with integrated PFC in appliance applications. Unlike a traditional microcontroller or DSP, IRMCF343 provides a built-in closed-loop sensorless control algorithm using a unique Motion Control Engine (MCE™) for surface/interior permanent magnet motors with sinusoidal back EMF. IRMCF343 also employs a unique single shunt current reconstruction circuit to eliminate additional analog/digital circuitry and enables a direct shunt resistor interface to the IC. The MCE™ consists of a collection of control elements, motion peripherals, a dedicated motion control sequencer and dual port RAM to map internal signal nodes. Motion control programming is achieved by using a dedicated graphical compiler integrated into the MATLAB/Simulink™ development environment. Sequencing, user interface, host communication, and upper layer control tasks can be implemented in the 8051 high-speed 8-bit microcontroller. The 8051 microcontroller is equipped with a JTAG port to facilitate emulation and debugging tools. Using the MCE™, IRMCF343 also achieves simultaneous digital PFC control of the frond-end circuit that provides a regulated DC bus voltage to the inverter.

Figure 1 shows the IRMCS3043 system block diagram. In this platform, the PFC topology is implemented as the conventional boost PFC; however, the IRMCF343 IC can also control the bridgeless PFC topology. Please contact the iMOTION™ team for support if you need to control the bridgeless PFC using IRMCF343.

The IRMCS3043 power stage contains a Trench IGBT (IRGP4063DPbF) for the PFC and an integrated power module (IRAMX16UP60A-2) for the inverter. The Trench IGBTs, part of IR’s iMOTION™ integrated design platform, have lower collector-to-emitter saturation voltage (VCE(ON)) and total switching energy (ETS) than punch-through (PT) and non-punch-through (NPT) type IGBTs. The combination of low VCE(ON) and ETS result in reduced power dissipation and higher power density. IRAMX16UP60A-2 is an integrated power module developed and optimized for appliance motor control.

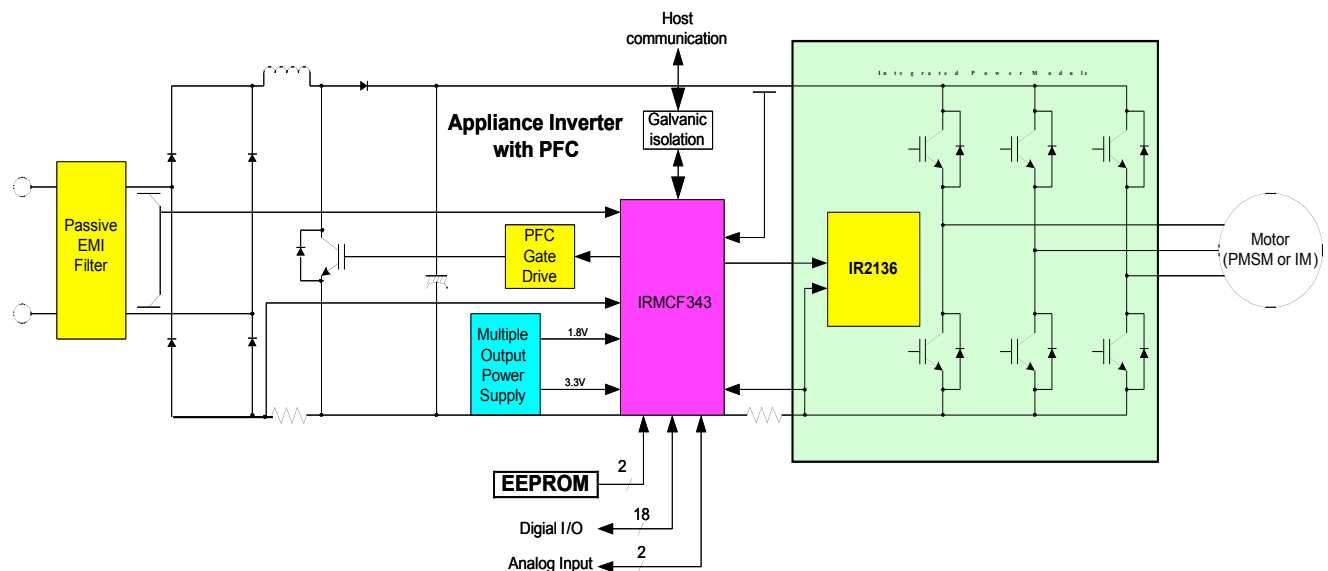

Figure 1. IRMCS3043 System Block Diagram

1.2 Safety Precautions

In addition to the precautions listed throughout this manual, please read and understand the following statements regarding hazards associated with development system.



ATTENTION: The ground potential of the IRMCS3043 system is biased to a negative DC bus voltage potential. When measuring voltage waveform by oscilloscope, the scope ground needs to be isolated. Failure to do so may result in personal injury or death.
Darkened display LEDs is not an indication that capacitors have discharged to safe voltage levels.

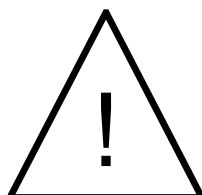

ATTENTION: IRMCS3043 system contains dc bus capacitors which take time to discharge after removal of main supply. Before working on drive system, wait three minutes for capacitors to discharge to safe voltage levels. Failure to do so may result in personal injury or death.
Darkened display LED is not an indication that capacitors have discharged to safe voltage levels.



ATTENTION: Only personnel familiar with the drive and associated machinery should plan or implement the installation, start-up, and subsequent maintenance of the system. Failure to comply may result in personal injury and/or equipment damage.



ATTENTION: The surface temperatures of the drive may become hot, which may cause injury.



ATTENTION: IRMCS3043 system contains ESD (Electrostatic Discharge) sensitive parts and assemblies. Static control precautions are required when installing, testing, servicing or repairing this assembly. Component damage may result if ESD control procedures are not followed. If you are not familiar with static control procedures, reference applicable ESD protection handbook and guideline.



ATTENTION: An incorrectly applied or installed drive can result in component damage or reduction in product life. Wiring or application errors such as undersizing the motor, supplying an incorrect or inadequate AC supply, or excessive ambient temperatures may result in system malfunction.



ATTENTION: Remove and lock out power from the drive before you disconnect or reconnect wires or perform service. Wait three minutes after removing power to discharge the bus voltage. Do not attempt to service the drive until bus voltage has discharged to zero. Failure to do so may result in bodily injury or death.



ATTENTION: Do not connect power factor correction inductors to drive output terminals U, V, and W. Failure to do so may result in equipment damage or bodily injury.

1.3 Debris When Unpacking

IRMCS3043 system is shipped with packing materials that need to be removed prior to installation.



ATTENTION: Failure to remove all debris and packing materials which are unnecessary for system installation may result in overheating or abnormal operating condition.

2 Hardware Description

A top view of IRMCS3043 is shown in Figure 2.

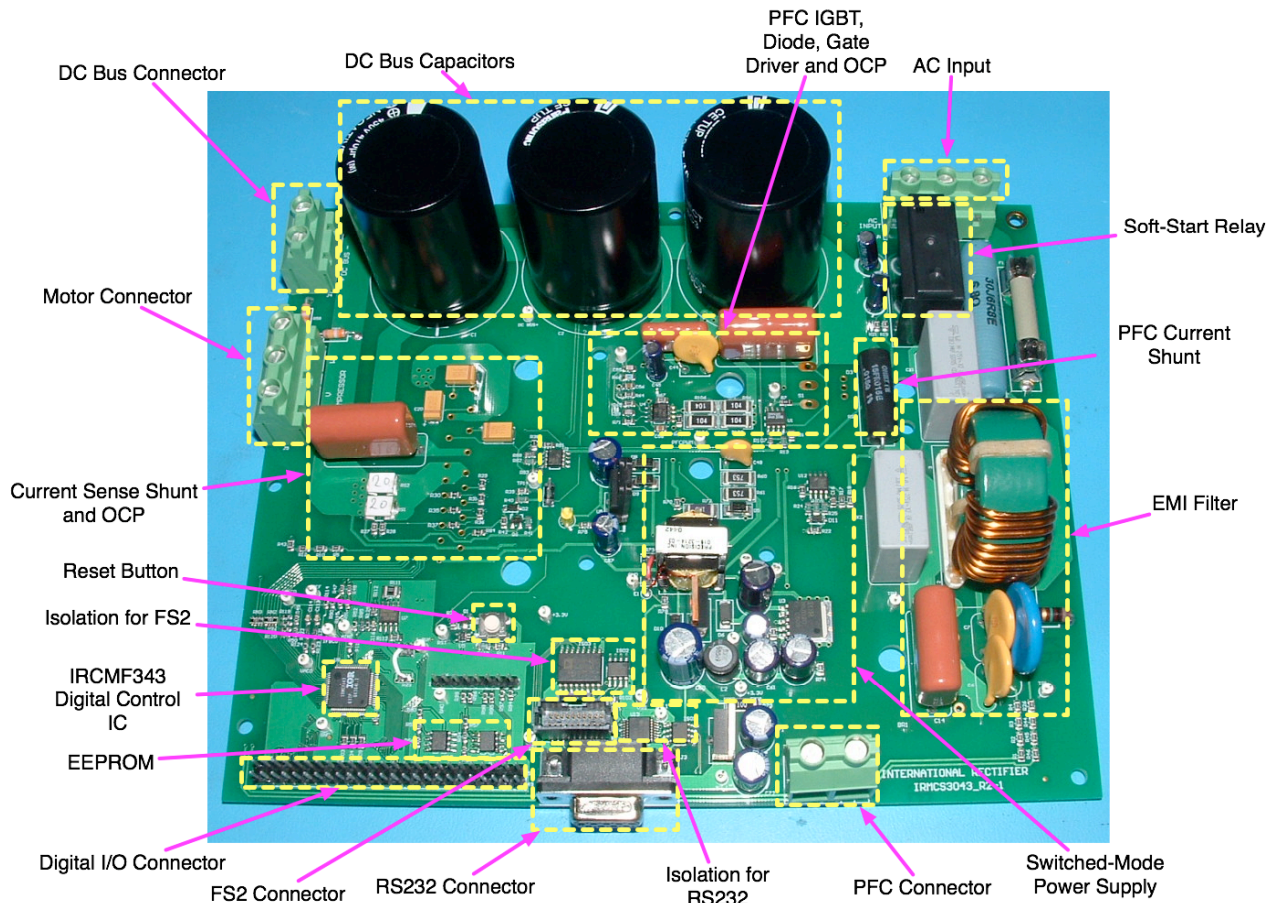

Figure 2. Top View of IRMCS3043



WARNING: Except the RS232 connector, all the circuits are directly biased to the negative DC bus of the power stage, and J7 JTAG, J6 D/A output and J8 digital I/O connectors are not isolated from the power ground. If an FS2 debugger or oscilloscope is needed for debugging or measurement, ensure it is isolated from the power ground. Otherwise, severe damage will occur to the PCB and /or the equipment.

2.1 PCB

The PCB has two electrical layers and its size is 6.5 x 8.0 inches.

2.2 Isolation Boundary

Note that there are two different grounds on this system. The RS232 connector is isolated by opto couplers so that users can connect a computer without isolating it. However, users should keep in mind that most parts of the hardware



have negative DC bus ground and it is necessary to isolate the scope when waveforms are measured and/or to isolate the FS2 debugger when debugging is conducted.

2.3 IRMCF343

2.3.1 Power

IRMCF343 requires 3.3V and 1.8V. VDD1 is 3.3V used for I/O and VDD2 is 1.8V for digital logic. AVDD is 1.8V for analog and PLLVDD is for PLL. Only one source of 1.8V is shared in IRMCS3043 system. Typical current value for 1.8V is less than 100 mA.

2.3.2 Crystal

A 4 MHz crystal is used to generate the system clock. The actual system frequency is adjustable by changing the Phase Locked Loop configuration through Special Function Registers. For more information regarding clock, please refer to the IRMCF34x and IRMCF37x User's Guide.

2.3.3 Reset Circuit

IRMCF343 doesn't require external RC circuit for reset. The reset switch is used when the JTAG debugger is started. For more information regarding reset, please refer to the IRMCF34x and IRMCF37x User's Guide.

2.3.4 EEPROM

Boot load takes place at power-up to load 8051 code and MCE code from an external EEPROM to internal RAM of IRMCF343. EEPROM can be written using the MCEDesigner tool.

2.3.5 Digital I/O

Most of the digital I/O's are connected to header J8 for the user's convenience.

2.3.6 Analog Output

Analog D/A output channels are connected to header J6 for ease of use.

2.3.7 Motor Single-Shunt Current Feedback

IRMCF343 contains an Operational Amplifier for the single shunt motor current reconstruction circuit. Resistors and capacitors for the amplifier circuit are placed very close to the pins. Note that, to provide better current feedback, there is a separate trace from the shunt resistor instead of sharing a plane with negative DC bus ground.

2.3.8 PFC Current Feedback

IRMCF343 contains an Operational Amplifier for PFC current feedback. The PFC current feedback signal is obtained through a shunt resistor that is in series with the PFC inductor and located at the negative DC bus side. Resistors and capacitors for the amplifier circuit are placed very close to the pins. Note that, to provide better current feedback, there is a separate trace from the shunt resistor instead of sharing a plain with negative DC bus ground.

2.3.9 AC Input Voltage Feedback

IRMCF343 contains an Operational Amplifier for AC input voltage feedback which is mainly used for PFC control. The AC input voltage signal is obtained through a proprietary differential amplifier circuit and control logic that is embedded inside of the IRMCF343 IC, together with a few external resistors and capacitors.

2.3.10 DC Bus Voltage Feedback

The DC bus voltage feedback is used in both motor control and PFC control. This is implemented through a voltage divider circuit, and the scaled-down analog signal is fed into an ADC input pin (AIN0) of IRMCF343.

2.4 Input Diode Bridge Rectifier

One piece of IR25XB08H diode bridge rectifier is mounted on a heat sink under the board.



2.5 PFC IGBT and Diode

At the PFC frond-end, one piece of IRGP4063DPbF trench IGBT and one piece of 30ETH06 hyperfast diode are mounted on the same heat sink under the board. A 15-m Ω shunt resistor is in series with the inductor current flowing path at the negative DC bus side. The shunt provides PFC current feedback as well as over-current protection (OCP). The voltage across the shunts is fed to a comparator circuit. The comparator initiates the over-current shutdown (PGatekill), and the PGatekill signal is fed to IRMCF343 IC. The OCP is about 20A peak. For more information regarding trench IGBTs and hyperfast diode, please refer to their datasheets.

2.6 PFC Inductor

One piece of PFC inductor is provided separately from the PCB, and should be connected to the J2 connector. The inductor shown in Figure 2 is 1.5mH at 15A Idc, with 10Arms current rating. You can use your own inductor for the evaluation and test. The choice of inductor involves trade-offs in PFC control performance (current ripple, harmonics and power factor), switching frequency, cost, space, power loss and EMI noise. The PFC switching frequency for the IRMCS3043 is 30kHz, and the typical recommended reasonable inductance range is about 1mH to 1.5mH.

2.7 IRAM

At the inverter side, one piece of IRAMX16UP60A-2 is mounted on the same heat sink under the board. There are two 20-m Ω shunt resistors (in parallel) that are inserted into the negative DC bus and external to the IRAM. These shunts provide motor current feedback as well as over-current protection. The voltage across the shunts is fed to a comparator circuit. The comparator initiates the over-current shutdown (CGatekill), and the CGatekill signal is fed to both the IRAM and IRMCF343 IC. With the 10-m Ω shunt resistance and threshold set up of the comparator, the OCP current is about 20A peak. For more information regarding IRAM, please refer to IRAM datasheet.

2.8 Power Supply

The switched-mode power supply (SMPS) operates at about 80 KHz and generates 15V(VCC), 5V and 3.3V. A 1.8V DC voltage is generated from 3.3V by a linear regulator IRU1208. All these voltages are biased to the negative DC bus. In addition, this SMPS also generates an isolated 12V which is used for the RS232 communication.

2.9 EMI Filter

The passive EMI filter on the board consists of two 1- μ F X-caps, two 4.7-nF Y-caps and a 4-mH common-mode inductor.

2.10 DC Bus Capacitors

Three pieces of 470- μ F, 450 V, 85 $^{\circ}$ C electrolytic capacitors are used as the DC bus capacitors.



3 Specifications

Tc = 25°C unless specified

Parameters	Values	Conditions
Input		
Voltage	220V-230Vrms, -20%, +10%	TA=40°C, RthSA=0.36 °C/W Vin=230V AC, fPWM_PFC =30kHz, fPWM_inverter =6kHz, fO=60Hz, TA=40°C, RthSA=0.36 °C/W
Frequency	50/60 Hz	
Input current	8A rms @nominal output	
Watts	1700W continuous power	
Input line impedance	4%~8% recommended	Input power > 1500W
Input power factor	>99%	
Harmonic current	Comply with EN61000-3-2 Class-A	
Output		
Current	6 Arms nominal, 10 Arms Overload	RthSA limits ΔTC to 10°C during overload
Host Interface (RS232C)		
TXD, RXD	10V	Typical 57.6 Kbps, single ended
JTAG interface		
TMS, TDI, TCK, TDO	3.3V	Interface with FS2 debugger (NOT isolated from the negative DC bus)
D/A		
8- bit 2 Channel	0-3.3V output	8051 software needs modification to use it.
A/D		
12-bit	0-1.2V	DC bus voltage, single-shunt motor current, AC input voltage, AC input current, AIN1
DC bus voltage		
Maximum DC bus voltage	400V	Should not exceed 400V for > 30 sec Configurable by PFC
Nominal DC bus voltage	370V	
PFC Current Feedback		
Current sensing device	Shunt resistor	
Resolution	12-bit	
Latency	1 PWM cycle	
Motor Current Feedback		
Current sensing device	Single shunt reconstruction	
Resolution	12-bit	
Latency	1 PWM cycle	
Protection		
PFC current trip level	20A peak, ±10%	Detection from shunt on inductor current return path
Motor current trip level	20A peak, ±10%	Detection from shunt on negative DC bus
Critical over voltage trip	430V	Re-scalable
Over voltage trip	410V	Re-scalable
Under voltage trip	120V	Re-scalable
Power Devices		
Trench IGBT for PFC	IRGP4063DPbF	
IPM for inverter	IRAMX16UP60A-2	
System Environment		
Ambient temperature	0 to 40°C	95% RH max. (Non-condensing)

Table 1. IRMCS3043 Electrical Specification



International
IOR Rectifier

IR WORLD HEADQUARTERS: 233 Kansas St., El Segundo, California 90245, Tel: (310) 252-7105
<http://www.irf.com> *Data and specifications subject to change without notice.*

Sales Offices, Agents and Distributors in Major Cities Throughout the World.