

MHF+ Single, Dual and Triple DC/DC Converters

28 VOLT INPUT – 15 WATT

FEATURES

Only 0.33 inches (8.38 mm) high in a hermetically sealed case

- Operating temperature -55° to $+125^{\circ}\text{C}$
- Input voltage 16 to 40 VDC
 - MHF+281R9S 20 to 32 VDC
 - Triple output models 16 to 48 VDC
- Transient protection
 - Single and dual: 50 V for 50 ms
 - Triple: 80 V for 120 ms
- Fully isolated
- Fixed high frequency switching
- Inhibit and synchronization functions
- Indefinite short circuit protection
- Up to 84% efficiency



MODELS VDC OUTPUT		
SINGLE	DUAL	TRIPLE
1.9	± 5	$+5$ & ± 12
3.3	± 12	$+5$ & ± 15
5	± 15	
5.2		
5.3		
12		
15		
28		

DESCRIPTION

MHF+ SINGLE AND DUAL DC/DC CONVERTERS

The MHF+ Single and Dual Series™ of high frequency DC/DC converters offers a wide input voltage range of 16 to 40 volts (MHF+281R9S, 20 to 32 volts) and up to 15 watts of output power. The units are capable of withstanding short term transients up to 50 volts. The converters are offered with standard screening, “ES” screening, or fully compliant to “883” MIL-PRF-38534 Class H screening. Standard microcircuit drawings (SMD) are available.

CONVERTER DESIGN

The MHF+ converters are switching regulators that use a quasi-square wave, single-ended forward converter design with a constant switching frequency of 550 kHz typical. Isolation between input and output circuits is provided with a transformer in the forward path and a temperature compensated optical link in the feedback control loop. See Figure 1.

For the MHF+ dual output models, good cross regulation is maintained by tightly coupled output magnetics. Up to 90% of the total output power (80% on 2805D) is available from either output, providing the opposite output is simultaneously carrying 10% of the total output power (20% on 2805D models). Predictable current limit is accomplished by directly monitoring the output load current and providing a constant current output above the overload point.

INHIBIT FUNCTION

MHF+ converters provide an inhibit terminal that can be used to disable internal switching, resulting in no output current and very low quiescent input current. The converter is inhibited when an active low of ≤ 0.8 V is applied to the inhibit pin. The unit is

enabled when the pin, which is internally connected to a pull-up resistor, is left unconnected or is connected to an open-collector gate. The open circuit output voltage associated with the inhibit pin is 8.5 to 12 V. In the inhibit mode, a maximum of 4 mA must be sunk from the inhibit pin. See Figure 3.

SYNCHRONIZATION

An external synchronization feature is included that allows the user to adjust the nominally 550 kHz operating frequency to any frequency within the range of 500 kHz to 600 kHz. This is initiated by applying a signal input of the desired frequency to pin 5. The capacitively coupled sync input will synchronize on a differential signal of as low as 4 volts to as high as 5 V. For single and dual output models, if the sync function is not used, connect the terminal to input common.

SHORT CIRCUIT PROTECTION

MHF+ Series single and dual output converters provide short circuit protection by restricting the output current to approximately 115% of the full load output current. The output current is sensed in the secondary stage to provide highly predictable and accurate current limiting, and to eliminate foldback characteristics.

UNDERVOLTAGE LOCKOUT

Undervoltage lockout prevents the single and dual output converters from operating below approximately 14 VDC input voltage to keep system current levels smooth, especially during initialization or re-start operations.

MHF+ Single, Dual and Triple DC/DC Converters

28 VOLT INPUT – 15 WATT

MHF+ SERIES™ TRIPLE DC/DC CONVERTERS

MHF+ Series™ Triple DC/DC converters provide a wide input voltage range of 16 to 48 VDC delivering 15 watts of total output power with output voltages of +5 and ± 12 or +5 and ± 15 VDC. The main output, +5 VDC, will supply up to 7.5 watts and the auxiliaries will supply up to 7.5 watts of combined power. Full power operation at -55° C to +125° C plus the ability to withstand transients of up to 80 V for up to 120 milliseconds make these converters an ideal choice for your high reliability systems.

CONVERTER DESIGN

MHF+ Triple Series of DC/DC converters incorporate dual-phase, phase-shifted technology with a continuous flyback topology. This design eliminates a minimum load requirement on the main output and eliminates cross regulation effects between the main output voltage and auxiliary output voltages. See Figure 2. The phase-shifted design offers reduced input and output ripple. To meet MIL-STD-461 requirements use an EMI filter, see Figure 5. FMH-461 is the recommended filter.

INHIBIT FUNCTION

An open collector inhibit terminal (pin 1) provides shut-down and start-up control. Applying an active low of ≤ 0.8 V, referenced to input common, will disable the output of the converter. When inhibited, input current is reduced to 5 mA or less and there is no generation of switching noise. The inhibit terminal typically sinks 3 mA when the converter is inhibited.

Leaving the terminal open or pulling it high will enable the converter. Use an open collector interface for active high voltages of up to 11 volts. (Refer to Figure 2 for a connection diagram.) An open collector interface is not required if the active high is in excess of the open circuit voltage of the inhibit terminal (11 volts) but less than 40 volts. See Figure 2.

MHF+ SERIES™ ALL MODELS

PACKAGING

MHF+ Series of converters are packaged in hermetically sealed metal cases and can be purchased in a flanged or non-flanged case. The flanged option provides increased heat dissipation and also provides greater stability when mechanically secured.

SOFT START FEATURE

The soft-start feature provides a controlled 25 milliseconds maximum turn-on to minimize inrush current and reduce overshoot at initial start-up or when inhibit is released.

SYNCHRONIZATION

To synchronize the converter's switching frequency to a system clock apply the clock signal to the sync terminal (pin 7). When multiple converters are powered from a single power source, asynchronous (free run) operation will result in lower peak noise for common spectral peaks, but synchronous operation will eliminate any possibility of interference frequencies in the low audio band. Source impedance of the signal should be less than 100 ohms and the transition time should be less than 100 nanoseconds. The capacitively coupled sync input will synchronize on a differential signal of as low as 4 volts to as high as 5 V. For triple output models, if the sync function is not used, the terminal should be left open. See Figure 4.

SHORT CIRCUIT PROTECTION

On the triple output models, internal current limiting circuitry protects on all three outputs against short circuits. When output power exceeds approximately 130% of maximum output power, the output currents are limited. In addition, separate current limiting circuitry protects each output individually resulting in normal operation of either the main or the auxiliaries, whichever is not in a shorted condition.

UNDERVOLTAGE LOCKOUT

Undervoltage lockout prevents the triple output models units from operating below approximately 8.5 VDC input voltage to keep system current levels smooth, especially during initialization or re-start operations.

OUTPUT VOLTAGE OPTIONS

The MHF+ Series converters are capable of providing other output voltage options in addition to those characterized on this datasheet. Contact your sales representative to discuss other output voltage options.

US PATENTS

Interpoint converters may use one or more of the following US patents 5,521,807, 5,694,303 and 5,631,822.

MHF+ Single, Dual and Triple DC/DC Converters

28 VOLT INPUT – 15 WATT

OPERATING CONDITIONS AND CHARACTERISTICS

Input Voltage Range

- Single and dual models:
 - 16 to 40 VDC continuous
 - MHF+281R9S 20 to 32 DC continuous
 - 50 V for up to 50 ms transient
 - MHF+281R9S 35 V for up to 50 ms transient
- Triple models:
 - 16 to 48 VDC continuous
 - 80 V for up to 120 ms transient

Output Power

- 6.65 to 15 watts depending on model

Power Dissipation (Pd)

- Single and dual models: 6 watts
- 1.9 and 3.3V single: 8 watts
- Triple models: 12 watts triple

Lead Soldering Temperature (10 sec per pin)

- 300°C

Storage Temperature Range (Case)

- -65°C to +150°C

Case Operating Temperature (T_C)

- -55°C to +125°C full power
- -55°C to +135°C absolute

Derating Output Power/Current

- Linearly from 100% at 125°C to 0% at 135°C

Output Voltage Temperature Coefficient

- 100 ppm/°C typical
- 150 ppm/°C maximum

Input to Output Capacitance

- 60 pF typical

Current Limit

- Single and dual models: 115% of full load typical
- Triple models: 130% of full load typical triple

Isolation

- 100 megohm minimum at 500 V

Audio Rejection

- 50 dB typical

Conversion Frequency (-55°C to +125°C T_C)

- Free run
 - Single and dual models: 480 kHz min, 550 kHz typ, 620 kHz max
 - Triple models: 375 kHz min, 500 kHz max

Undervoltage Lockout

- Single and dual models: 14 V input typical
- Triple models: 8.5 V input typical

SYNC AND INHIBIT

Sync In

- Input frequency
 - Single and dual models: 500 to 600 kHz
 - Triple models: 400 to 600 kHz
 - Duty cycle 40% to 60%
- Active low 0.8 V max
- Active high 4 V min, 5 V max
- Triple models: source impedance should be <100 ohms and the transition time should be <100 nanoseconds
- If sync is not used
 - Single and dual models: connect to input common
 - Triple models: leave unconnected
- Referenced to input common

Inhibit:

- Active low (output disabled)
 - Active low voltage ≤0.8 V max
 - Inhibit pin current
 - Single and dual models: 4.0 mA max, 3.0 mA typ
 - Triple models: 5.0 mA max, 3.0 mA typ
 - Referenced to input common
 - Active high (output enabled)
 - Single and dual models
 - Open collector or unconnected
 - Open pin 8.5 to 12 V, 10 V typical
 - Triple models
 - Open collector or unconnected
 - Open collector interface not required if active high is greater than 11 V and less than 40V
 - Open pin voltage, 11 V typical

MECHANICAL AND ENVIRONMENTAL

Size (maximum)

- Non flanged 1.460 x 1.130 x 0.330 (37.08 x 28.70 x 8.38 mm)
- Flanged 2.005 x 1.130 x 0.330 (50.93 x 28.70 x 8.38 mm)
- See cases E1, E2, G1 and G2 for dimensions.

Weight, flanged or unflanged (maximum)

- Single and dual models: 30 grams
- Triple models: 35 grams

Screening:

Standard, ES or 883 (Class H). See Screening Tables 1 and 2 for more information.

MHF+ Single, Dual and Triple DC/DC Converters

28 VOLT INPUT – 15 WATT

SIMPLIFIED SCHEMATIC DIAGRAMS

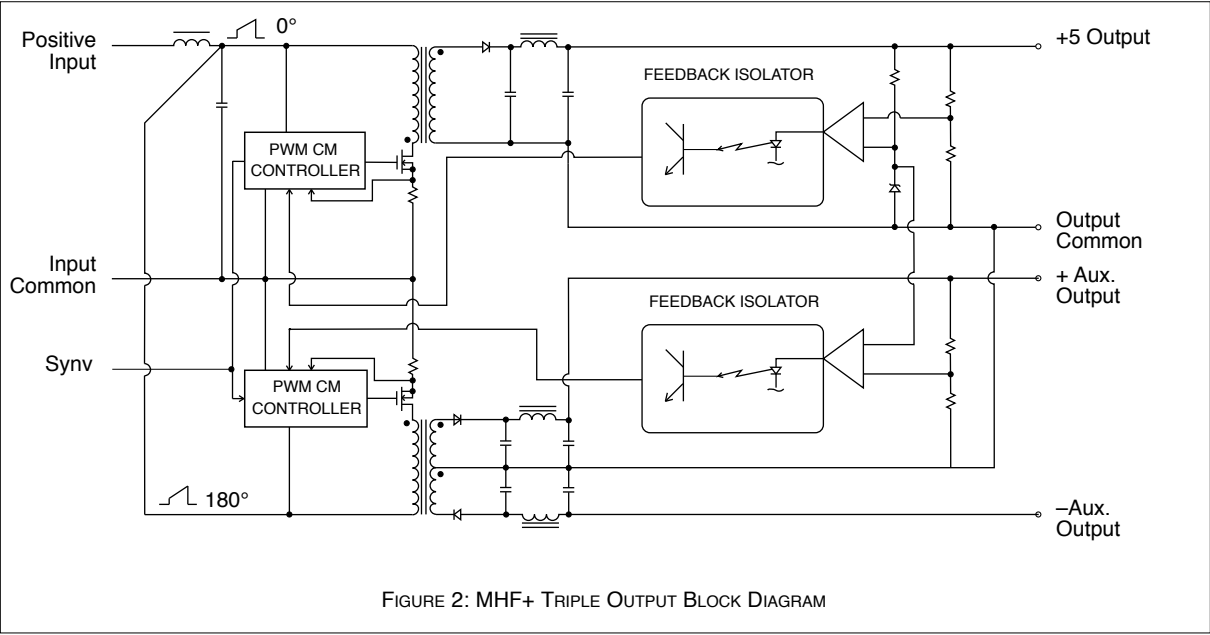
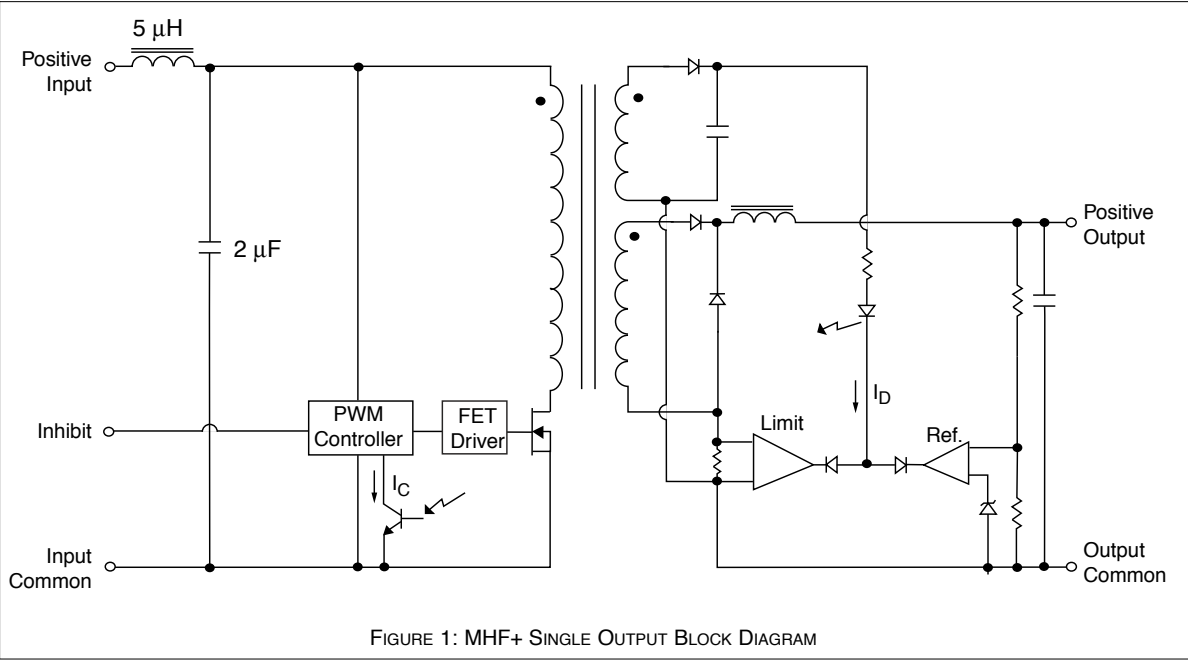

MHF+ Single, Dual and Triple DC/DC Converters

28 VOLT INPUT – 15 WATT

CONNECTION DIAGRAMS

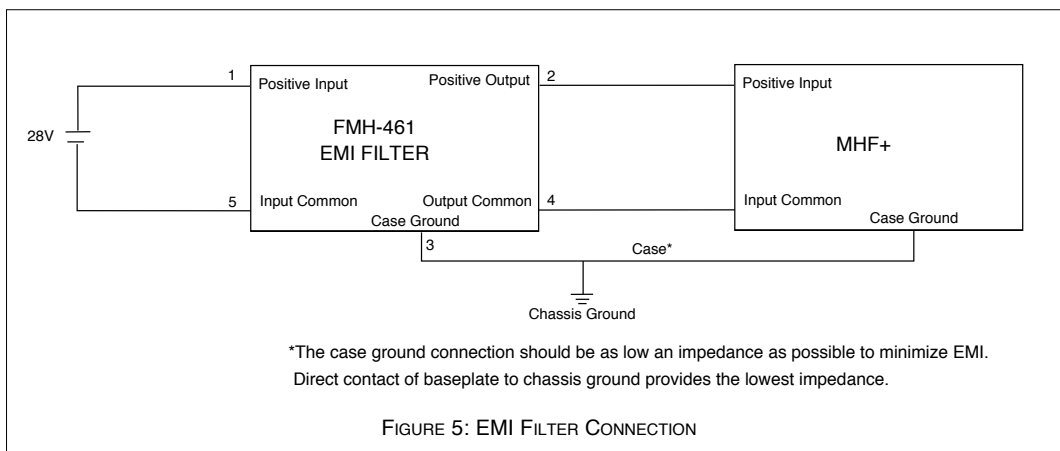
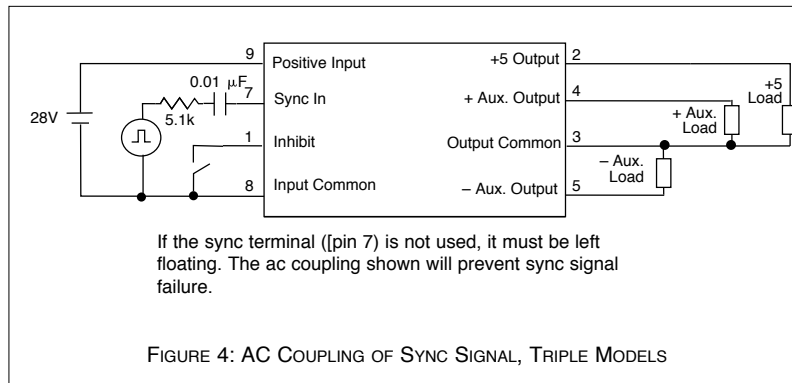
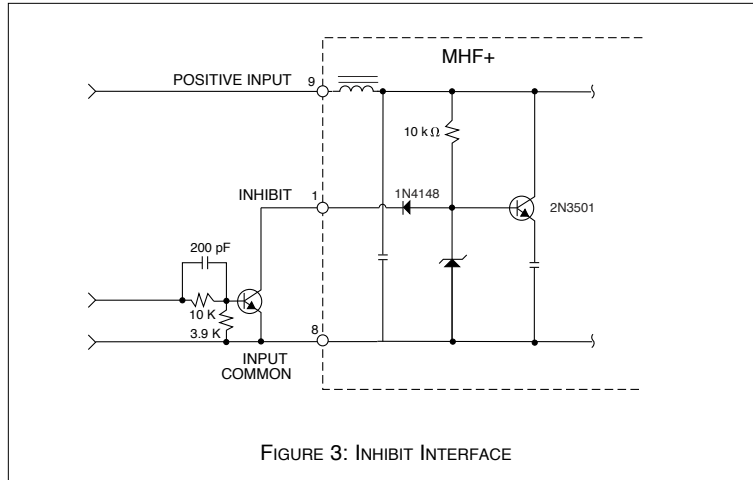

MHF+ Single, Dual and Triple DC/DC Converters

28 VOLT INPUT – 15 WATT

PIN OUT				
Pin	Single Output	MHF+2828S	Dual Output	Triple Output
1	Inhibit	Inhibit	Inhibit	Inhibit
2	No Connection	Positive Output	Positive Output	Main (+5) Output
3	Output Common	(See note 1)	Output Common	Output Common
4	Positive Output	Output Common	Negative Output	Pos. Aux. Output
5	Sync In	Sync In	Sync In	Neg. Aux. Output
6	Case Ground	Case Ground	Case Ground	Case Ground
7	Input Common	Input Common	Input Common	Sync
8	Positive Input	Positive Input	Positive Input	Input Common
9	—	—	—	Positive Input

1. Pin 3 of MHF+2828S will provide 14 Vout referenced to output common (pin 4).

PINS NOT IN USE	
Inhibit: single, dual and triple, pin 1	Leave unconnected
MHF+2828S, pin 3	Leave unconnected
Sync: single and dual, pin 5	Connect to input common
Sync: triple, pin 7	Leave unconnected

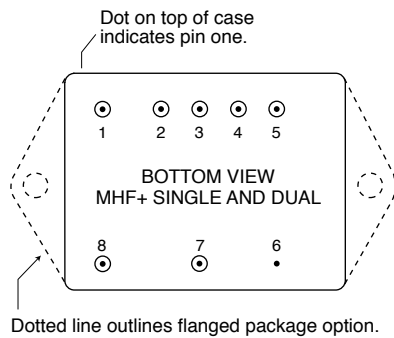

See cases E1 and G1 for dimensions.

FIGURE 6: MHF+ SINGLE AND DUAL PIN OUT

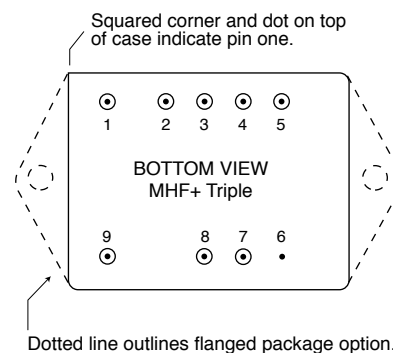

See cases E2 and G2 for dimensions.

FIGURE 7: MHF+ TRIPLE PIN OUT

MHF+ Single, Dual and Triple DC/DC Converters

28 VOLT INPUT – 15 WATT

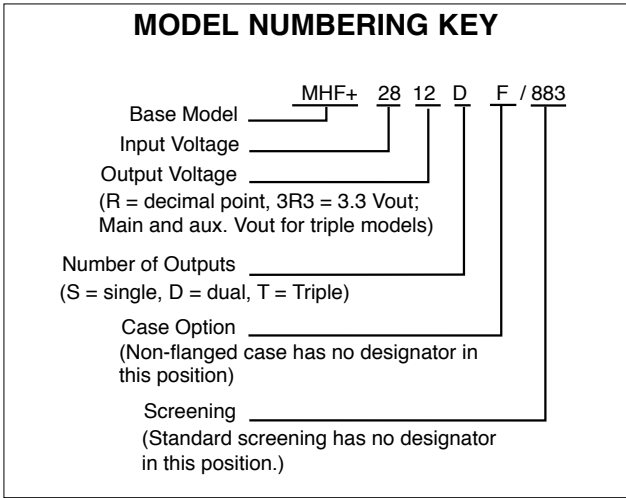

SMD NUMBERS	
STANDARD MICROCIRCUIT DRAWING (SMD)	MHF+ SIMILAR PART
5962-0251001HXC	MHF+283R3S/883
5962-9213901HXC	MHF+2805S/883
5962-0325301HXC	MHF+285R2S/883
5962-9166401HXC	MHF+2812S/883
5962-9160101HXC	MHF+2815S/883
5962-9689801HXC	MHF+2828S/883
5962-9555901HXC	MHF+2805D/883
5962-9214401HXC	MHF+2812D/883
5962-9161401HXC	MHF+2815D/883
5962-9560101HXC	MHF+28512T/883
5962-9560201HXC	MHF+28515T/883

Flanged SMDs have the suffix HZC instead of HXC.

For exact specifications for an SMD product, refer to the SMD drawing. SMDs can be downloaded from <http://www.dscc.dla.mil/programs/smcr>

MODEL SELECTION					
ON THE LINES BELOW, ENTER ONE SELECTION FROM EACH CATEGORY TO DETERMINE THE MODEL NUMBER.					
CATEGORY	MHF+28 Base Model and Input Voltage	_____ Output Voltage ¹	_____ Number of Outputs ²	_____ Case/Lead Options ³	/ _____ Screening ⁴
SELECTION	MHF+28 is the only available option	1R9, 3R3, 05, 5R2, 5R3, 12, 15, 28	S	(NON-FLANGED leave blank)	(STANDARD leave blank)
		05, 12, 15	D	F (FLANGED)	ES
		512, 515	T		883

Notes:

- Output Voltage: An R indicates a decimal point. 1R9 is 1.9 volts out. The values of 1R9, 3R3, 5R2 and 5R3 are only available in single output models. The 512 and 515 triple output converters are +5 volt main and ±12 or ±15 volt auxiliaries.
- Number of Outputs: S is a single output, D is a dual output, and T is a triple output
- Case Options: For the standard case (non-flanged) leave the case option blank. For the flanged case, use an F in the case option.
- Screening: For standard screening leave the screening option blank. For other screening options, insert the desired screening level. For more information see Screening Tables 1 and 2.

MHF+ Single, Dual and Triple DC/DC Converters

28 VOLT INPUT – 15 WATT

Electrical Characteristics: -55° TO +125°C T_C, 28 VDC Vin, 100% load, free run, unless otherwise specified.

SINGLE OUTPUT MODELS		MHF+281R9S			MHF+283R3S			MHF+2805S			UNITS
PARAMETER	CONDITIONS	MIN	TYP	MAX	MIN	TYP	MAX	MIN	TYP	MAX	
OUTPUT VOLTAGE		1.84	1.90	1.96	3.20	3.30	3.40	4.85	5.00	5.15	VDC
OUTPUT CURRENT	V _{IN} = 16 TO 40 VDC	0	–	3.5	0	–	2.4	0	–	2.4	A
OUTPUT POWER	V _{IN} = 16 TO 40 VDC	0	–	6.65	0	–	8	0	–	12	W
OUTPUT RIPPLE	T _C = 25°C	–	7	30	–	30	80	–	30	80	mV p-p
10 kHz - 2 MHz		–	12	40	–	50	240	–	60	100	
LINE REGULATION	V _{IN} = 16 TO 40 VDC	–	1	40	–	5	100	–	5	50	mV
LOAD REGULATION	NO LOAD TO FULL ²	–	35	55	–	20	50	–	20	50	mV
INPUT VOLTAGE	CONTINUOUS	20	28	32	16	28	40	16	28	40	VDC
NO LOAD TO FULL	TRANSIENT 50 ms ¹	–	–	35	–	–	50	–	–	50	V
INPUT CURRENT	NO LOAD	–	16	35	–	25	40	–	25	40	mA
	INHIBITED	–	2	7	–	5	12	–	5	12	
INPUT RIPPLE CURRENT	T _C = 25°C	–	30	60	–	45	80	–	35	80	mA p-p
10 kHz - 10 MHz		–	–	70	–	–	120	–	–	100	
EFFICIENCY		56	62	–	67	75	–	72	77	–	%
LOAD FAULT ^{3, 4}	POWER DISSIPATION SHORT CIRCUIT	–	4	8	–	5	8	–	3.5	6	W
	RECOVERY ¹	–	5	30	–	7.5	30	–	7.5	30	ms
STEP LOAD RESPONSE ^{4, 5}	50% - 100% - 50% TRANSIENT	–	±75	±500	–	±150	±400	–	±150	±400	mV pk
	RECOVERY	–	500	2000	–	150	300	–	150	300	μs
STEP LINE RESPONSE ^{1, 4, 5}	16 - 40 - 16 VDC ⁶ TRANSIENT	–	±300	±600	–	±550	±800	–	±550	±800	mV pk
	RECOVERY	–	0.5	1.2	–	0.8	1.2	–	0.8	1.2	ms
START-UP ⁵	DELAY	–	12	35	–	10	25	–	10	25	ms
	OVERSHOOT ¹	–	500	850	–	200	300	–	100	600	mV pk
CAPACITIVE LOAD ¹		–	–	100	–	–	300	–	–	300	μF

Notes

1. Guaranteed by design, not tested.

2. For MHF+281R9, load regulation is tested from a 10 mA load to full load.

3. Indefinite short circuit protection not guaranteed above 125°C (case).

4. Recovery time is measured from application of the transient to the point at which V_{OUT} is within regulation.

5. Step transition time >10 μs.

6. Step line is 20 - 32 - 20 VDC for MHF+281R39S.

MHF+ Single, Dual and Triple DC/DC Converters

28 VOLT INPUT – 15 WATT

Electrical Characteristics: -55° TO +125°C T_C, 28 VDC Vin, 100% load, free run, unless otherwise specified.

SINGLE OUTPUT MODELS		MHF+285R2S			MHF+285R3S			MHF+2812S			UNITS
PARAMETER	CONDITIONS	MIN	TYP	MAX	MIN	TYP	MAX	MIN	TYP	MAX	
OUTPUT VOLTAGE		5.04	5.20	5.36	5.19	5.35	5.51	11.76	12.00	12.24	VDC
OUTPUT CURRENT	V _{IN} = 16 TO 40 VDC	0	—	2.4	0	—	2.83	0	—	1.25	A
OUTPUT POWER	V _{IN} = 16 TO 40 VDC	0	—	12.48	0	—	15	0	—	15	W
OUTPUT RIPPLE 10 kHz - 2 MHz	T _C = 25°C	—	30	50	—	30	50	—	30	80	mV p-p
		—	60	100	—	60	100	—	50	120	
LINE REGULATION	V _{IN} = 16 TO 40 VDC	—	5	50	—	5	50	—	5	50	mV
LOAD REGULATION	NO LOAD TO FULL	—	20	50	—	20	50	—	20	50	mV
INPUT VOLTAGE NO LOAD TO FULL	CONTINUOUS	16	28	40	16	28	40	16	28	40	VDC
	TRANSIENT 50 ms ¹	—	—	50	—	—	50	—	—	50	V
INPUT CURRENT	NO LOAD	—	25	43	—	24	43	—	25	50	mA
	INHIBITED	—	5	12	—	5	12	—	5	12	
INPUT RIPPLE CURRENT 10 kHz - 10 MHz	T _C = 25°C	—	35	80	—	35	80	—	35	80	mA p-p
		—	—	120	—	—	120	—	—	120	
EFFICIENCY		72	77	—	72	77	—	74	79	—	%
LOAD FAULT ^{2,3}	POWER DISSIPATION SHORT CIRCUIT	—	3.5	6	—	3.5	6	—	3.5	6	W
	RECOVERY ¹	—	7.5	30	—	7.5	30	—	7.5	30	ms
STEP LOAD RESPONSE ^{4,3}	50% - 100% - 50% TRANSIENT	—	±150	±400	—	±150	±400	—	±150	±500	mV pk
	RECOVERY	—	150	300	—	150	300	—	150	300	μs
STEP LINE RESPONSE ^{1,3,4}	16 - 40 - 16 VDC TRANSIENT	—	±550	±800	—	±550	±800	—	±550	±800	mV pk
	RECOVERY	—	0.8	1.2	—	0.8	1.2	—	0.8	1.2	ms
START-UP ⁴	DELAY	—	10	25	—	10	25	—	10	25	ms
	OVERSHOOT ¹	—	100	600	—	100	600	—	200	1200	mV pk
CAPACITIVE LOAD ¹		—	—	300	—	—	300	—	—	100	μF

Notes

1. Guaranteed by design, not tested.

2. Indefinite short circuit protection not guaranteed above 125°C (case).

3. Recovery time is measured from application of the transient.

to the point at which V_{OUT} is within regulation.

4. Step transition time >10 μs.

MHF+ Single, Dual and Triple DC/DC Converters

28 VOLT INPUT – 15 WATT

Electrical Characteristics: -55° TO +125°C T_C, 28 VDC V_{IN}, 100% load, free run, unless otherwise specified.

SINGLE OUTPUT MODELS		MHF+2815S			MHF+2828S			UNITS
PARAMETER	CONDITIONS	MIN	TYP	MAX	MIN	TYP	MAX	
OUTPUT VOLTAGE		14.70	15.00	15.30	27.44	28.00	28.56	VDC
OUTPUT CURRENT	V _{IN} = 16 TO 40 VDC	0	—	1.00	0	—	0.536	A
OUTPUT POWER	V _{IN} = 16 TO 40 VDC	0	—	15	0	—	15	W
OUTPUT RIPPLE	T _C = 25°C	—	30	80	—	60	120	mV p-p
10 kHz - 2 MHz		—	50	120	—	100	180	
LINE REGULATION	V _{IN} = 16 TO 40 VDC	—	5	50	—	50	150	mV
LOAD REGULATION	NO LOAD TO FULL	—	20	50	—	50	150	mV
INPUT VOLTAGE	CONTINUOUS	16	28	40	16	28	40	VDC
NO LOAD TO FULL	TRANSIENT 50 ms ¹	—	—	50	—	—	50	V
INPUT CURRENT	NO LOAD	—	25	62	—	25	60	mA
	INHIBITED	—	5	12	—	5	12	
INPUT RIPPLE CURRENT	T _C = 25°C	—	35	80	—	35	80	mA p-p
10 kHz - 10 MHz		—	—	120	—	—	120	
EFFICIENCY		74	80	—	78	84	—	%
LOAD FAULT ^{2, 3}	POWER DISSIPATION	—	3.5	6	—	3.5	6	W
	SHORT CIRCUIT	—	3.5	6	—	3.5	6	W
	RECOVERY ¹	—	7.5	30	—	7.5	30	ms
STEP LOAD RESPONSE ^{3, 4}	50% - 100% - 50% TRANSIENT	—	±200	±600	—	±600	±800	mV pk
	RECOVERY	—	150	300	—	200	400	μs
STEP LINE RESPONSE ^{1, 3, 4}	16 - 40 - 16 VDC TRANSIENT	—	±550	±800	—	±1100	±1200	mV pk
	RECOVERY	—	0.8	1.2	—	0.8	1.2	ms
START-UP ⁴	DELAY	—	10	25	—	10	25	ms
	OVERSHOOT ¹	—	200	1500	—	200	280	mV pk
CAPACITIVE LOAD ¹		—	—	100	—	—	100	μF

Notes

1. Guaranteed by design, not tested.

2. Indefinite short circuit protection not guaranteed above 125°C (case).

3. Recovery time is measured from application of the transient .
to the point at which V_{OUT} is within regulation.

4. Step transition time >10 μs.

MHF+ Single, Dual and Triple DC/DC Converters

28 VOLT INPUT – 15 WATT

Electrical Characteristics: -55° TO +125°C T_C, 28 VDC V_{IN}, 100% load, free run, unless otherwise specified.

DUAL OUTPUT MODELS		MHF+2805D			MHF+2812D			MHF+2815D			UNITS
PARAMETER	CONDITIONS	MIN	TYP	MAX	MIN	TYP	MAX	MIN	TYP	MAX	
OUTPUT VOLTAGE	+V _{OUT}	4.85	5.00	5.15	11.76	12.00	12.24	14.70	15.00	15.30	VDC
	-V _{OUT}	4.82	5.00	5.18	11.70	12.00	12.30	14.63	15.00	15.38	
OUTPUT CURRENT ^{2, 3} V _{IN} = 16 TO 40 VDC	EACH OUTPUT	0	±1.2	1.92 ¹	0	±0.625	1.125 ¹	0	±0.50	0.90 ¹	A
	TOTAL	—	—	2.4	—	—	1.25	—	—	1.0	
OUTPUT POWER ^{2, 3} V _{IN} = 16 TO 40 VDC	EACH OUTPUT	0	±6	9.6 ¹	0	±7.5	13.5 ¹	0	±7.5	13.5 ¹	W
	TOTAL	—	—	12	—	—	15	—	—	15	
OUTPUT RIPPLE ±V _{OUT} , 10kHz - 2 MHz	T _C = 25°C	—	30	80	—	30	80	—	30	60	mV p-p
		—	60	80	—	60	120	—	50	120	
LINE REGULATION V _{IN} = 16 TO 40 VDC	+V _{OUT}	—	5	50	—	5	50	—	5	50	mV
	-V _{OUT}	—	—	80	—	—	100	—	—	100	
LOAD REGULATION BALANCED LOADS NO LOAD TO FULL	+V _{OUT}	—	20	50	—	20	50	—	20	50	mV
	-V _{OUT}	—	—	100	—	—	100	—	—	100	
CROSS REGULATION ⁴	25°C EFFECT ON -V _{OUT}	—	6	7.5	—	3	6	—	3	5	%
INPUT VOLTAGE	CONTINUOUS	16	28	40	16	28	40	16	28	40	VDC
	TRANSIENT 50 ms ¹	—	—	50	—	—	50	—	—	50	V
INPUT CURRENT	NO LOAD	—	20	40	—	25	50	—	25	50	mA
	INHIBITED	—	6	12	—	5	12	—	5	12	
INPUT RIPPLE CURRENT 10 kHz - 10 MHz	T _C = 25°C	—	20	50	—	35	60	—	35	60	mA p-p
		—	40	80	—	50	100	—	50	100	
EFFICIENCY		75	79	—	74	83	—	75	84	—	%
LOAD FAULT ^{5, 6}	POWER DISSIPATION SHORT CIRCUIT	—	3	6	—	3	6	—	3	6	W
	RECOVERY ¹	—	7.5	30	—	7.5	30	—	7.5	30	ms
STEP LOAD RESPONSE ^{7, 8} 50% - 100% - 50% BALANCED LOADS	TRANSIENT +V _{OUT}	—	±200	±600	—	±300	±700	—	±300	±700	mV pk
	TRANSIENT -V _{OUT}	—	±150	±600	—	±100	±700	—	±100	±700	
	RECOVERY	—	150	500	—	200	500	—	200	500	μs
STEP LINE RESPONSE ^{1, 8} ±V _{OUT}	16 - 40 - 16 V _{IN} TRANSIENT	—	±600	±800	—	±550	±750	—	±550	±750	mV pk
	RECOVERY	—	0.8	1.2	—	0.8	1.2	—	0.8	1.2	ms
START-UP ⁸ V _{IN} = 40 V	DELAY	—	12	20	—	12	25	—	12	25	ms
	OVERSHOOT ¹	—	80	250	—	200	750	—	200	750	mV pk
CAPACITIVE LOAD ¹		—	—	47	—	—	10	—	—	10	μF

Notes (see following page)

MHF+ Single, Dual and Triple DC/DC Converters

28 VOLT INPUT – 15 WATT

Electrical Characteristics: -55° TO +125°C TC, 28 VDC Vin, 100% load, free run, unless otherwise specified.

Notes for Dual Output Models

1. Guaranteed by design, not tested.

2. Up to 13.5 watts, 90% (9.6 watts, 80% for 2805D) of the total output power is available from either output provided that the opposite output is simultaneously carrying 10% (20% for 2805D) of the total output power. One of the outputs must always provide a minimum of 10% (20% for 2805D) of the total output power used to meet cross regulation. Negative Vout cross regulation is referenced to 50%/50% balanced loads (at 100% of total rated output power - full load).

3. The "Total" specification is the maximum combined current/power of both outputs.

4. Effect on $-V_{OUT}$ for the following conditions, A and B:

Condition A:

+P_o = 50% to 10% and -P_o = 50%

+P_o = 50% and -P_o = 50% to 10%

Condition B, outputs are switched simultaneously between the "From" and "To" conditions:

From +P_o = 70%, -P_o = 30%

To +P_o = 30%, -P_o = 70%

Both conditions are referenced to the balanced loads

condition: 50%/50%

5. Indefinite short circuit protection not guaranteed above 125°C (case)

6. Recovery time is measured from application of the transient to point at which V_{OUT} is within regulation.

7. Response of either output with the opposite output held at half of the total output power.

8. Step transition time >10 μs.

MHF+ Single, Dual and Triple DC/DC Converters

28 VOLT INPUT – 15 WATT

Electrical Characteristics: -55° TO +125°C T_C, 28 VDC Vin, 100% load, free run, unless otherwise specified.

TRIPLE OUTPUT MODEL – MHF+28512T		5 ² (MAIN)			±12 (AUXILIARIES)			UNITS
PARAMETER	CONDITIONS	MIN	TYP	MAX	MIN	TYP	MAX	
OUTPUT VOLTAGE	V _{OUT}	4.85 ²	5.00	5.15	±11.52	±12.00	±12.48	VDC
OUTPUT CURRENT ³		—	—	1.5	0	±0.313	0.416 ¹	A
	TOTAL	—	—	1.5	—	—	0.625	
OUTPUT POWER ⁴ V _{IN} = 16 - 48 VDC		—	—	7.5	—	±3.75	5 ¹	W
	TOTAL	—	—	7.5	—	—	7.5	
OUTPUT RIPPLE	10 kHz - 2 MHz	—	20	90	—	±30	±180	mV p-p
LINE REGULATION	V _{IN} = 16 TO 48 VDC	—	25	75	—	±120	±240	mV
LOAD REGULATION ⁶	NO LOAD TO FULL	—	22	75	—	±120	±240	mV
CROSS REGULATION ⁶ T _C = 25°C	EFFECT ON NEGATIVE AUXILIARY	—	—	—	—	—	6.25	%
INPUT VOLTAGE	CONTINUOUS	16	28	48	—	—	—	VDC
	TRANSIENT ¹ 120 ms	—	—	80	—	—	—	V
INPUT CURRENT	NO LOAD	—	30	45	—	—	—	mA
	INHIBITED	—	3	5	—	—	—	
INPUT RIPPLE CURRENT	10 kHz - 20 MHz	—	20	50	—	—	—	mA p-p
EFFICIENCY		72	76	—	—	—	—	%
LOAD FAULT ^{7,9}	POWER DISSIPATION SHORT CIRCUIT	—	—	12	—	—	±12	W
	RECOVERY ¹	—	—	25	—	—	25	ms
STEP LOAD RESPONSE ^{8,9}	TRANSIENT	—	—	±850	—	—	±950	mV pk
	RECOVERY	—	5	8	—	2	3	ms
STEP LINE RESPONSE ^{1,9,10}	16 - 48 - 16 TRANSIENT	—	—	±800	—	—	±800	mV pk
	RECOVERY	—	—	5	—	—	5	ms
START-UP	DELAY NO LOAD AND FULL	—	10	25	—	10	±25	ms
	OVERSHOOT ¹	—	—	500	—	—	±500	mV pk

Notes

1. Guaranteed by design, not tested.

2. If running with external sync, at temperature extremes V_{OUT} main may be a minimum of 4.80 VDC to a maximum of 5.20 VDC.

3. The sum of the 12 volt auxiliary output currents may not exceed 625 mA.

4. The sum of the auxiliary output power may not exceed 7.5 watts. Up to 5 watts (approximately 66%) of the total auxiliary output power is available from either output providing the opposite output is simultaneously carrying 2.5 watts (approximately 33%) of the total auxiliary power.

5. Load regulation for the +5 is specified at 0.0 to 1.5 A with the auxiliaries both held at 3.75 W (313 mA). Load regulation for the auxiliaries is specified as both auxiliaries from 0.0 to 3.75 W (313 mA) at the same time with the +5 held at 1.5 A.

6. Cross regulation only occurs between the two auxiliaries and is measured on -aux. +5 is held constant at 1.0 A. Cross regulation is specified for two conditions:

Negative aux. = 3.76 W; positive aux. = 0.37 W to 3.76 W.

Negative aux. = 0.37 W to 3.76 W; positive aux. = 3.76 W.

7. Load fault = < 0.100 Ω.

8. Step transition time > 10 μs.

9. Time to settle to within 1% of V_{OUT} final value.

10. Step transition time between 2 and 10 μs.

MHF+ Single, Dual and Triple DC/DC Converters

28 VOLT INPUT – 15 WATT

Electrical Characteristics: -55° TO +125°C T_C, 28 VDC Vin, 100% load, free run, unless otherwise specified.

TRIPLE OUTPUT MODEL – MHF+28515T		5 ² (MAIN)			±15 (AUXILIARIES)			UNITS
PARAMETER	CONDITIONS	MIN	TYP	MAX	MIN	TYP	MAX	
OUTPUT VOLTAGE	V _{OUT}	4.85	5.00	5.15	14.40	15.00	15.60	VDC
OUTPUT CURRENT ³		–	–	1.5	0	±0.250	0.333 ¹	A
	TOTAL	–	–	1.5	–	–	0.500	
OUTPUT POWER ⁹ V _{IN} = 16 TO 48 VDC		–	–	7.5	–	±2.5	5 ¹	W
	TOTAL	–	–	–	–	–	7.5	
OUTPUT RIPPLE	10 kHz - 2 MHz	–	20	90	–	±30	±225	mV p-p
LINE REGULATION	V _{IN} = 16, 48 VDC	–	25	75	–	±150	±300	mV
LOAD REGULATION ⁵ NO LOAD TO FULL	V _{IN} = 28 VDC	–	25	75	–	±150	±300	mV
CROSS REGULATION ⁶ T _C = 25°C	EFFECT ON NEGATIVE AUXILIARY OUTPUT	–	–	–	–	–	5.0	%
INPUT VOLTAGE	CONTINUOUS	16	28	48	–	–	–	VDC
	TRANSIENT ¹ 120 ms	–	–	80	–	–	–	V
INPUT CURRENT	NO LOAD	–	30	45	–	–	–	mA
	INHIBITED	–	3	5	–	–	–	
INPUT RIPPLE CURRENT	10 kHz - 20 MHz	–	20	50	–	–	–	mA p-p
EFFICIENCY		72	76	–	–	–	–	%
LOAD FAULT ^{7,9}	POWER DISSIPATION SHORT CIRCUIT	–	–	12	–	–	±12	W
	RECOVERY ¹	–	–	25	–	–	25	ms
STEP LOAD RESPONSE ^{8,9}	TRANSIENT	–	–	±850	–	–	±950	mV pk
	RECOVERY	–	5	8	–	2	3	ms
STEP LINE RESPONSE ^{1,9,10}	16 - 48 - 16 V _{IN} TRANSIENT	–	–	±800	–	–	±800	mV pk
	RECOVERY	–	–	5	–	–	5	ms
START-UP	DELAY NO LOAD AND FULL	–	10	25	–	10	25	ms
	OVERSHOOT ¹	–	–	500	–	–	±500	mV pk

Notes

1. Guaranteed by design, not tested.

- If running with external sync, at temperature extremes V_{OUT} main may be a minimum of 4.80 VDC to a maximum of 5.20 VDC.
- The sum of the 15 volt auxiliary output currents may not exceed 500 mA.
- The sum of the auxiliary output power may not exceed 7.5 watts. Up to 5 watts (approximately 66%) of the total auxiliary output power is available from either output providing the opposite output is simultaneously carrying 2.5 watts (approximately 33%) of the total auxiliary power.
- Load regulation for the +5 is specified at 0.0 to 1.5 A with both auxiliaries held at 3.75 W (250 mA). Load regulation for the auxiliary. is specified as both auxiliaries from 0.0 to 3.75 W (250 mA) at the same time with the +5 held at 1.5 A.

- Cross regulation only occurs between the two auxiliaries and is measured on –aux. +5 is held constant at 1.0 A. Cross regulation is specified for two conditions:
Negative aux.= 3.76 W; positive aux.= 0.37 W to 3.76 W.
Negative aux. = 0.37 W to 3.76 W; positive aux. = 3.76 W.
- Load fault = < 0.100 Ω.
- Step transition time > 10 μs.
- Time to settle to within 1% of V_{OUT} final value.
- Step transition time between 2 and 10 μs.

MHF+ Single, Dual and Triple DC/DC Converters

28 VOLT INPUT – 15 WATT

Typical Performance Curves: 25°C Tc , 28 VDC Vin, 100% load, free run, unless otherwise specified.

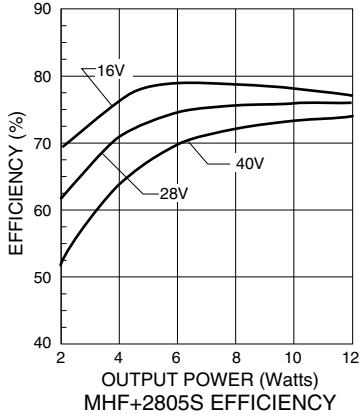

FIGURE 8

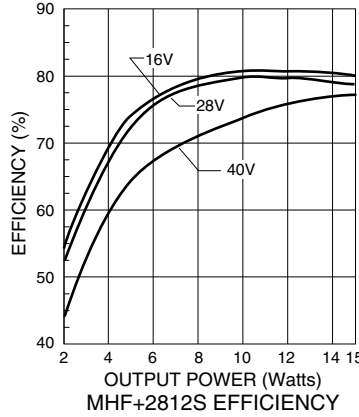

FIGURE 9

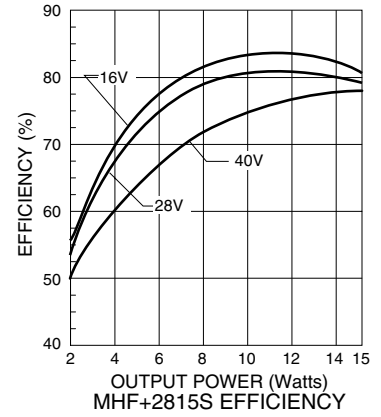

FIGURE 10

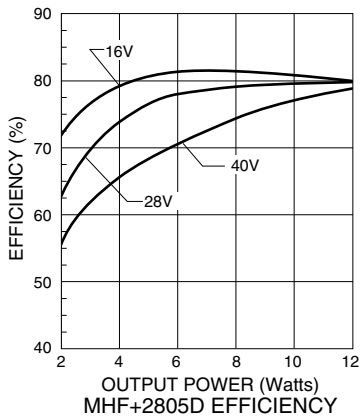

FIGURE 11

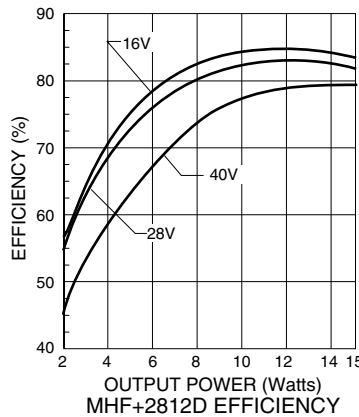

FIGURE 12

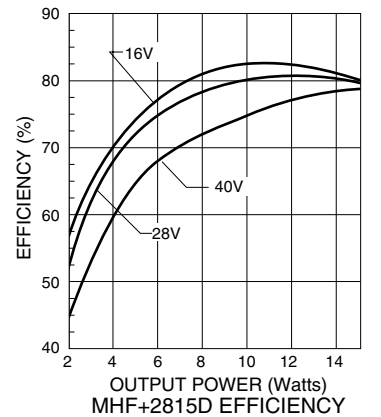

FIGURE 13

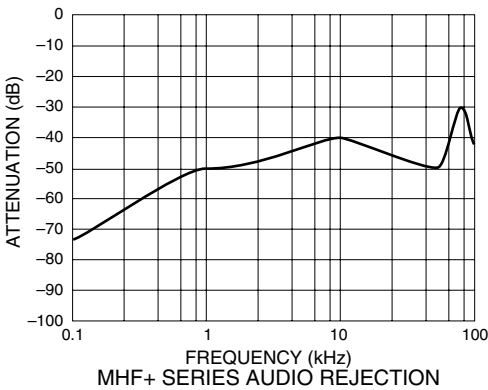

FIGURE 14

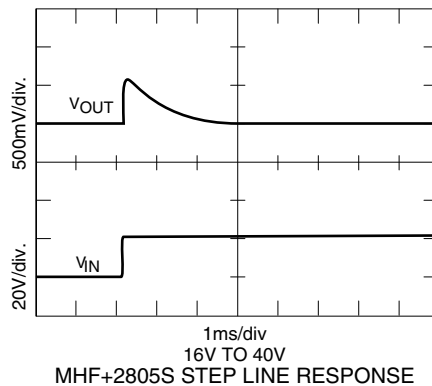

FIGURE 15

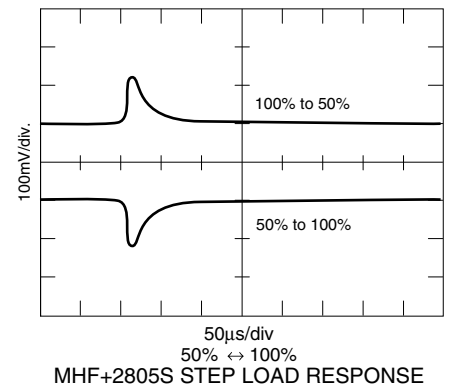

FIGURE 16

MHF+ Single, Dual and Triple DC/DC Converters

28 VOLT INPUT – 15 WATT

Typical Performance Curves: 25°C Tc , 28 VDC Vin, 100% load, free run, unless otherwise specified.

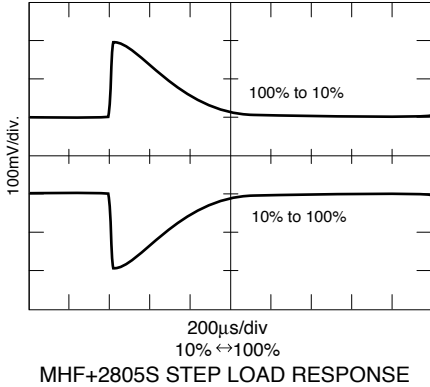

FIGURE 17

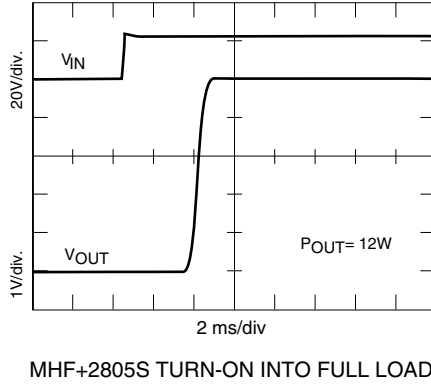

FIGURE 18

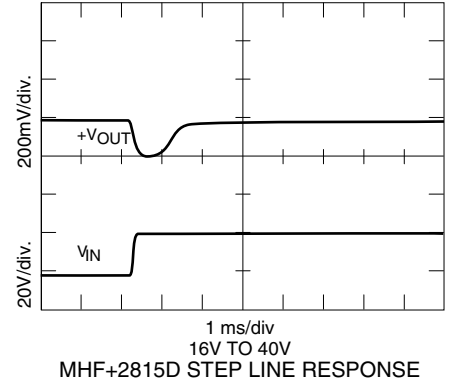

FIGURE 19

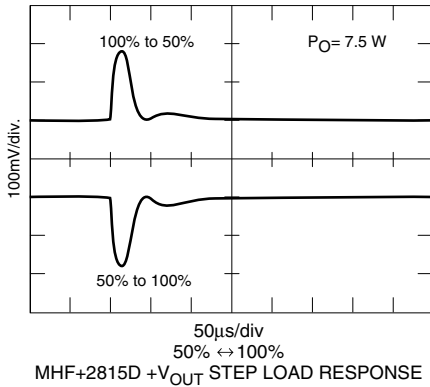

FIGURE 20

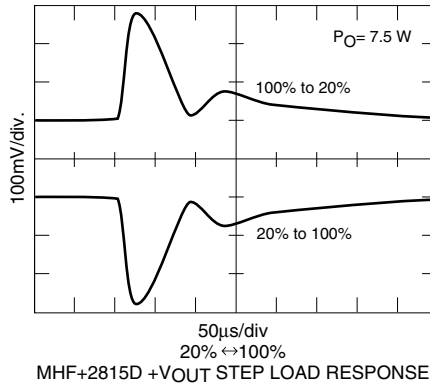

FIGURE 21

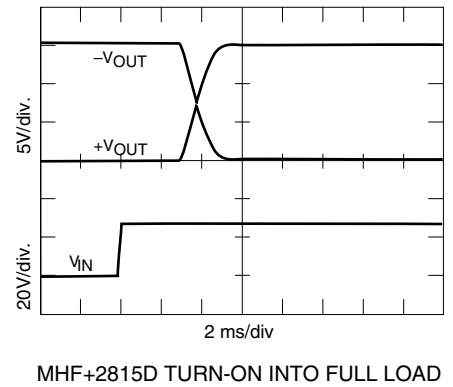

FIGURE 22

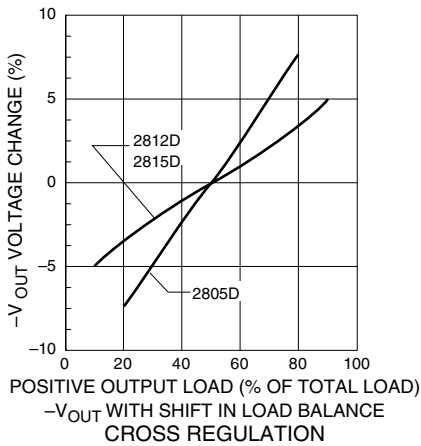

FIGURE 23

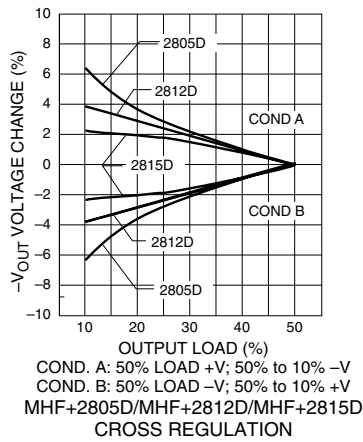

FIGURE 24

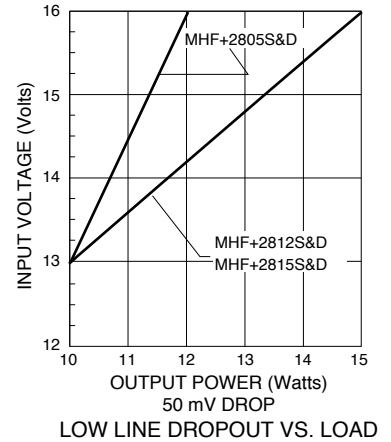

FIGURE 25

MHF+ Single, Dual and Triple DC/DC Converters

28 VOLT INPUT – 15 WATT

Typical Performance Curves: 25°C Tc , 28 VDC Vin, 100% load, free run, unless otherwise specified.

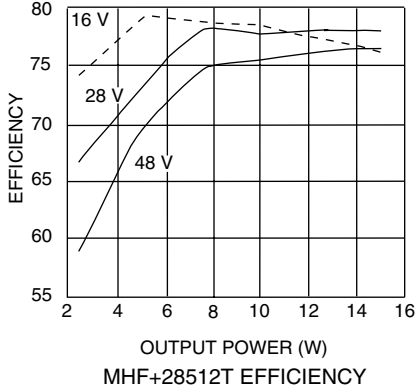

FIGURE 26

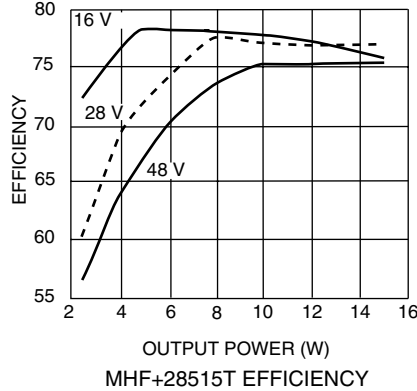
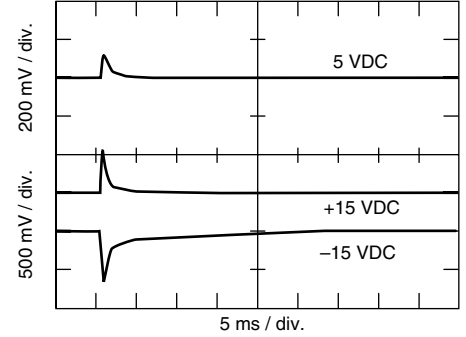

FIGURE 27



INPUT V: 16 TO 40 VDC, ±15 = 250 mA EACH, +5 = 1.5 A

MHF+ 28515T STEP LINE RESPONSE

MHF+28512T has a similar response
FIGURE 28

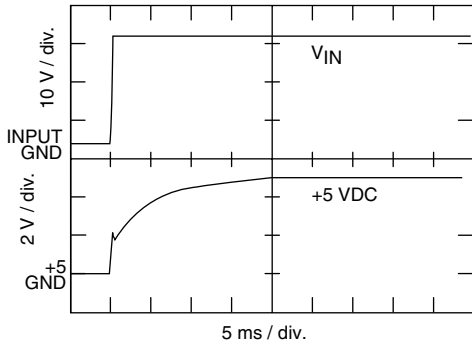

MHF+28512T TURN ON INTO FULL LOAD MAIN

MHF+28515T has a similar response
FIGURE 29

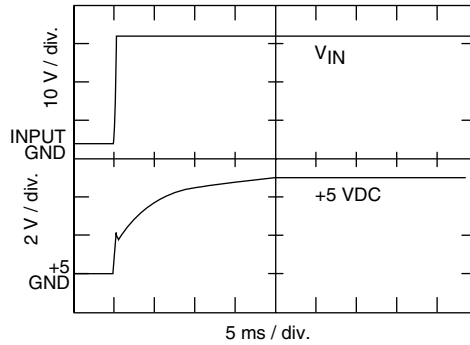

MHF+28515T TURN ON INTO FULL LOAD MAIN

MHF+28515T has a similar response
FIGURE 30

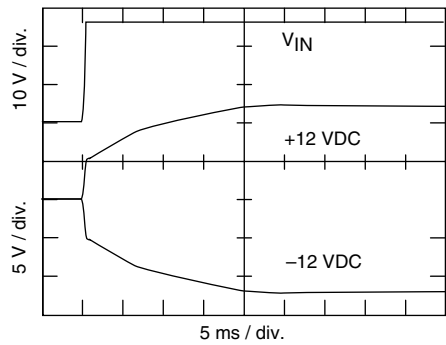

MHF+28512T TURN ON INTO FULL LOAD AUXILIARIES

MHF+28515T has a similar response

FIGURE 31

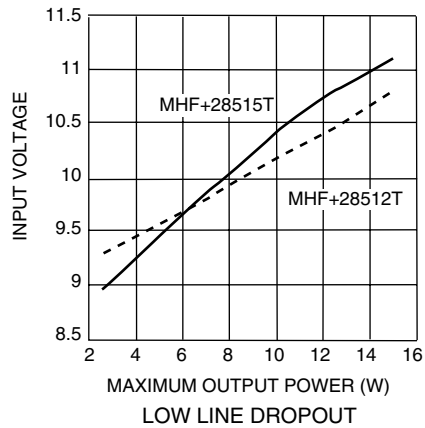
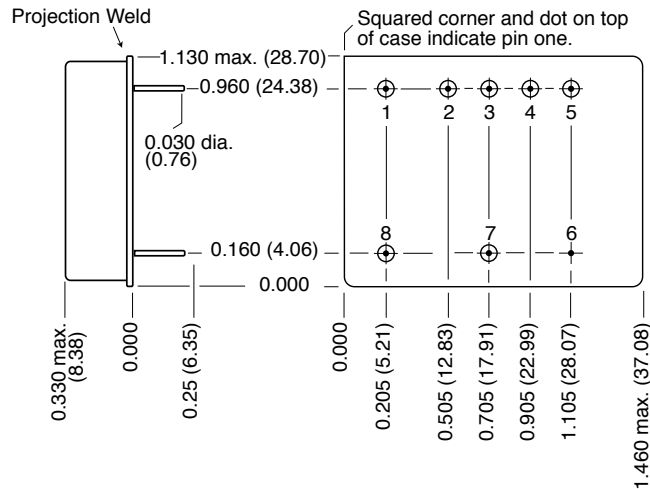

FIGURE 32

MHF+ Single, Dual and Triple DC/DC Converter Cases

28 VOLT INPUT – 15 WATT

BOTTOM VIEW CASE E1



Case dimensions in inches (mm)

Tolerance ± 0.005 (0.13) for three decimal places
 ± 0.01 (0.3) for two decimal places
 unless otherwise specified

CAUTION

Heat from reflow or wave soldering may damage the device. Solder pins individually with heat application not exceeding 300°C for 10 seconds per pin.

Materials

Header Cold Rolled Steel/Nickel/Gold
 Cover Kovar/Nickel
 Pins #52 alloy/Gold compression glass seal.
 Seal Hole: 0.080 ± 0.002 (2.03 ± 0.05)

Case E1, Rev D, 20091105

Please refer to the numerical dimensions for accuracy. All information is believed to be accurate, but no responsibility is assumed for errors or omissions. Interpoint reserves the right to make changes in products or specifications without notice.
 Copyright © 1999-2009 Interpoint Corp. All rights reserved.

FIGURE 33: CASE E1— SINGLE AND DUAL MODELS

MHF+ Single, Dual and Triple DC/DC Converter Cases

28 VOLT INPUT – 15 WATT

BOTTOM VIEW CASE E2

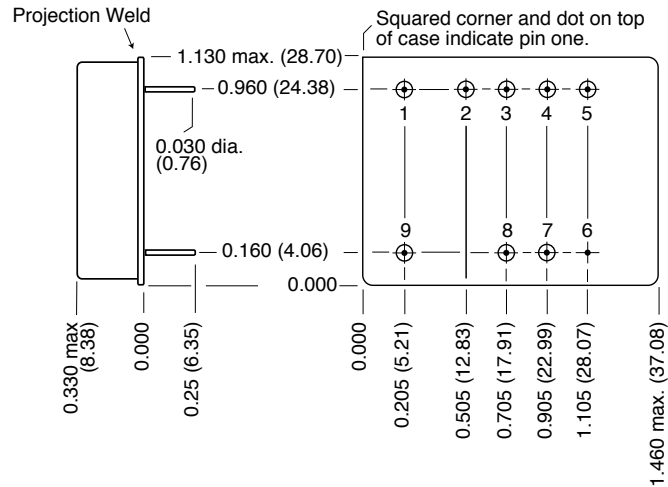

Case dimensions in inches (mm)

Tolerance ± 0.005 (0.13) for three decimal places
 ± 0.01 (0.3) for two decimal places
 unless otherwise specified

CAUTION

Heat from reflow or wave soldering may damage the device. Solder pins individually with heat application not exceeding 300°C for 10 seconds per pin.

Materials

Header Cold Rolled Steel/Nickel/Gold
 Cover Kovar/Nickel
 Pins #52 alloy/Gold compression glass seal.
 Seal Hole: 0.080 ± 0.002 (2.03 ± 0.05)

Case E2, Rev D, 20091105

Please refer to the numerical dimensions for accuracy. All information is believed to be accurate, but no responsibility is assumed for errors or omissions. Interpoint reserves the right to make changes in products or specifications without notice.
 Copyright © 1999-2009 Interpoint Corp. All rights reserved.

FIGURE 34: CASE E2 — TRIPLE MODELS

MHF+ Single, Dual and Triple DC/DC Converter Cases

28 VOLT INPUT – 15 WATT

BOTTOM VIEW CASE G1

Flanged cases: Designator "F" required in Case Option position of model number

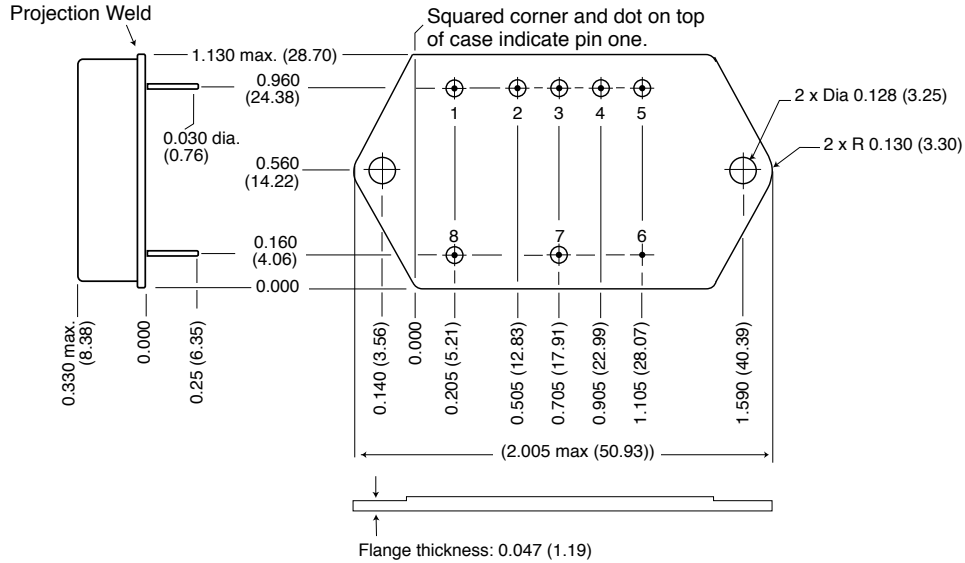

Case dimensions in inches (mm)

Tolerance ± 0.005 (0.13) for three decimal places
 ± 0.01 (0.3) for two decimal places
 unless otherwise specified

CAUTION

Heat from reflow or wave soldering may damage the device. Solder pins individually with heat application not exceeding 300°C for 10 seconds per pin.

Materials

Header Cold Rolled Steel/Nickel/Gold
 Cover Kovar/Nickel
 Pins #52 alloy/Gold compression glass seal.
 Seal Hole: 0.080 \pm 0.002 (2.03 \pm 0.05)

Case G1, Rev C, 20091105

Please refer to the numerical dimensions for accuracy. All information is believed to be accurate, but no responsibility is assumed for errors or omissions. Interpoint reserves the right to make changes in products or specifications without notice. Copyright © 1999-2009 Interpoint Corp. All rights reserved.

FIGURE 35: CASE G1 — SINGLE AND DUAL MODELS

MHF+ Single, Dual and Triple DC/DC Converter Cases

28 VOLT INPUT – 15 WATT

BOTTOM VIEW CASE G2

Flanged cases: Designator "F" required in Case Option position of model number

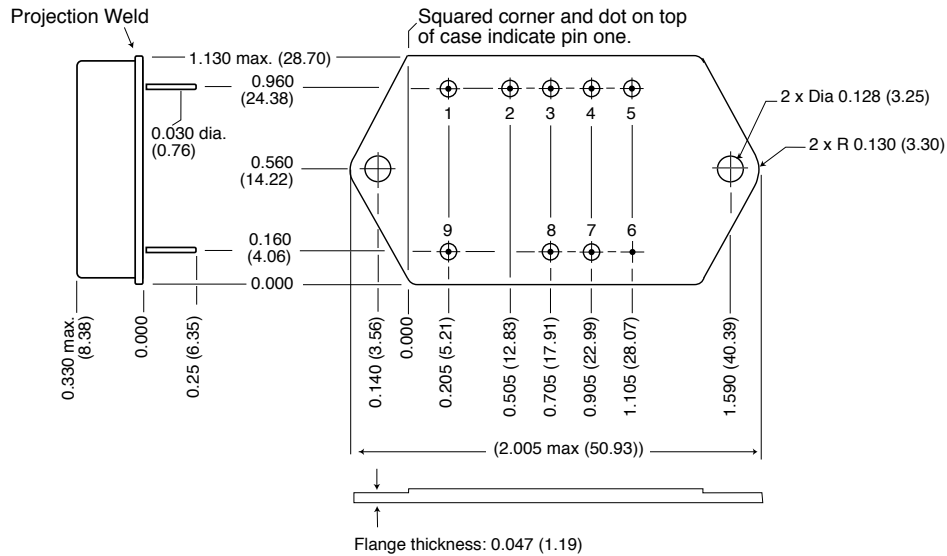

Case dimensions in inches (mm)

Tolerance ± 0.005 (0.13) for three decimal places
 ± 0.01 (0.3) for two decimal places
 unless otherwise specified

CAUTION

Heat from reflow or wave soldering may damage the device. Solder pins individually with heat application not exceeding 300°C for 10 seconds per pin.

Materials

Header Cold Rolled Steel/Nickel/Gold
 Cover Kovar/Nickel
 Pins #52 alloy/Gold compression glass seal.
 Seal Hole: 0.080 ± 0.002 (2.03 ± 0.05)

Case G2, Rev D, 20091105

Please refer to the numerical dimensions for accuracy. All information is believed to be accurate, but no responsibility is assumed for errors or omissions. Interpoint reserves the right to make changes in products or specifications without notice. Copyright © 1999-2009 Interpoint Corp. All rights reserved.

FIGURE 36: CASE G2 — TRIPLE MODELS

MHF+ Single, Dual and Triple DC/DC Converters

28 VOLT INPUT – 15 WATT

STANDARD AND /ES (NON-QML) AND /883 (CLASS H, QML) PRODUCT ELEMENT EVALUATION

COMPONENT-LEVEL TEST PERFORMED	STANDARD AND /ES NON-QML ¹		/883 CLASS H QML	
	M/S ²	P ³	M/S ²	P ³
Element Electrical (probe)	yes	no	yes	yes
Element Visual	no	no	yes	yes
Internal Visual	no	N/A	yes	N/A
Final Electrical	no	no	yes	yes
Wire Bond Evaluation ⁴	no	no	yes	yes
SLAM™/C-SAM: Input capacitors only (Add'l test, not req. by H)	no	no	no	yes

Notes:

1. Standard and /ES, non-QML products, do not meet all of the requirements of MIL-PRF-38534.
2. M/S = Active components (Microcircuit and Semiconductor Die)
3. P = Passive components
4. Not applicable to EMI filters that have no wire bonds.

Definitions:

Element Evaluation: Component testing/screening per MIL-STD-883 as determined by MIL-PRF-38534
 SLAM™: Scanning Laser Acoustic Microscopy
 C-SAM: C - Mode Scanning Acoustic Microscopy

SCREENING TABLE 1: ELEMENT EVALUATION

MHF+ Single, Dual and Triple DC/DC Converters

28 VOLT INPUT – 15 WATT

STANDARD AND /ES (NON-QML) AND /883 (CLASS H, QML) PRODUCT ENVIRONMENTAL SCREENING

TEST PERFORMED	125°C STANDARD NON-QML ¹	125°C /ES NON-QML ¹	/883 CLASS H QML
Pre-cap Inspection Method 2017, 2032	yes	yes	yes
Temperature Cycle (10 times) Method 1010, Cond. C, -65°C to 150°C, ambient Method 1010, Cond. B, -55°C to 125°C, ambient	no no	no yes	yes no
Constant Acceleration Method 2001, 3000 g Method 2001, 500 g	no no	no yes	yes no
Burn-in ² Method 1015, 125°C case, typical 96 hours 160 hours	no no	yes no	no yes
Final Electrical Test MIL-PRF-38534, Group A Subgroups 1 through 6: -55°C, +25°C, +125°C case Subgroups 1 and 4: +25°C case	no yes	no yes	yes no
Hermeticity Test Fine Leak, Method 1014, Cond. A Gross Leak, Method 1014, Cond. C Gross Leak, Dip (1 x 10 ⁻³)	no no yes	yes yes no	yes yes no
Final visual inspection Method 2009	yes	yes	yes

Test methods are referenced to MIL-STD-883 as determined by MIL-PRF-38534.

Notes:

- Standard and /ES, non-QML products, do not meet all of the requirements of MIL-PRF-38534.
- Burn-in temperature designed to bring the case temperature to +125°C

SCREENING TABLE 2: ENVIRONMENTAL SCREENING