

1.6A, 500KHz Synchronous Step-up Converter

DESCRIPTION

The EUP2410 is a highly efficient, synchronous, fixed frequency, current-mode step-up converter with output to input disconnect. When EUP2410 is disabled, the internal conduction path from SW to OUT is fully blocked and the OUT pin is isolated from the battery. This output disconnect feature reduces the shutdown current to typically only 50nA.

The 500KHz switching frequency allows for smaller external components producing a compact solution for a wide range of load currents. Highly integration and internal compensation network minimizes as 5 external components, N-Channel switch and P-Channel Synchronous switch integration will greatly improve converter efficiency. Internal soft-start function also reduce inrush current. The EUP2410 regulates the output voltage up to 6V from either a 2-cell NiMH/NiCd or a single-cell Li-Ion battery.

The EUP2410 is offered in a thin SOT23-5 package.

FEATURES

- Over 90% Efficiency
- 1.6A Typical Switch Current Limit
- 500KHz Fixed Switching Frequency
- Output to Input Disconnect at Shutdown Mode
- Internal Synchronous Rectifier
- Internal Soft-Start
- Internal Compensation
- 50nA Shutdown Current
- Thermal Shutdown
- 5-Pin TSOT-23 Package
- RoHS compliant and 100% lead(Pb)-free

APPLICATIONS

- GPS PND
- Handheld Digital Audio
- Digital Still and Video Cameras
- White LED Flash

Typical Application Circuit

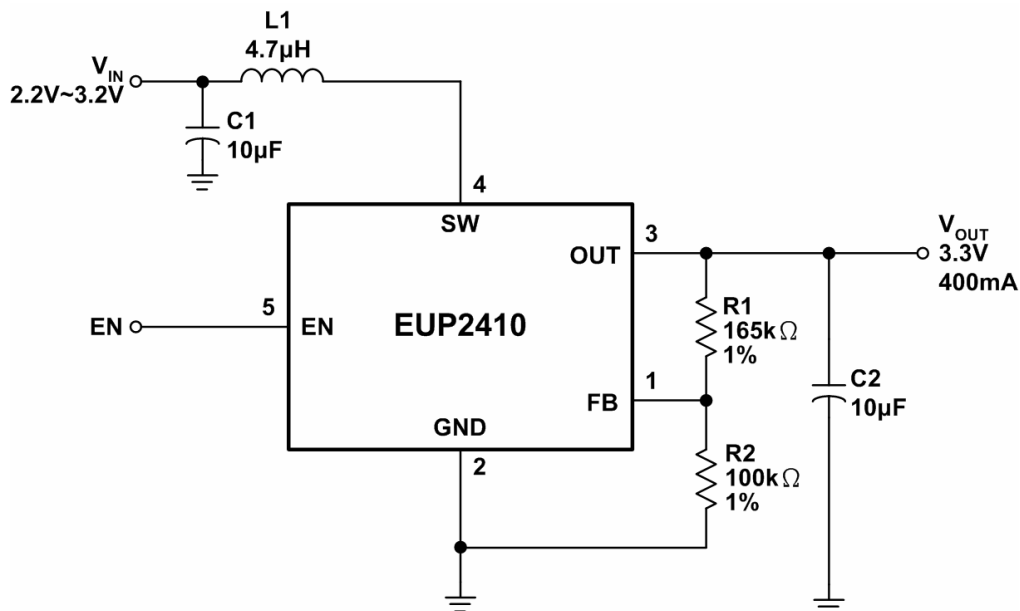

Figure1.