

**PRODUCT SUMMARY****CX20529: CDMA/FM/GPS Baseband Analog Processor****APPLICATIONS**

- Tri-band, quad-mode mobile phones (including E911 capabilities)
- GPS receivers

**FEATURES**

- Single supply voltage 2.7 to 3.3 V
- Operational temperature  $-30\text{ }^{\circ}\text{C}$  to  $+85\text{ }^{\circ}\text{C}$
- Low power consumption in all operating modes including sleep operation
- Dual mode for CDMA and FM operation with GPS position location capability
- Receive signal path includes:
  - Separate CDMA, FM, GPS filters, and A/Ds
  - DC offset control loop
- Receive VHF PLL synthesizer:
  - Programmable charge pump current
  - Lock detector output
- System clock generation:
  - 19.2, 19.68, and 19.8 MHz system clock support
  - Accepts external CHIPx8 clock (9.8304 MHz or 8.184 MHz) and generates an internal CHIPx8 clock (9.8304 MHz)
  - Adjustable TCXO or TCXO/4 clock output driver levels and power-down capability
  - Provides a TCXO clock through the TCXO/4 output pin
- Mode control logic for Rx, sleep, idle, and GPS modes
- Pin-for-pin and functionality compatible with the CX20489 (but with GPS processing capability added)
- Available in a 40-pin, 6 x 6 mm LGA package

The CX20529 is a receive-only Baseband Analog Processor (BAP) that can be used for Code Division Multiple Access (CDMA), Advanced Mobile Phone System (AMPS) Frequency Modulation (FM), and Global Positioning System (GPS) baseband signals. The device is designed for dual-mode CDMA and AMPS portable phones with GPS capability.

The CX20529 is designed to interface between the Radio Frequency (RF) receive section and the digital processing circuitry of the telephone. The device includes all of the circuitry needed to support the receive baseband signal processing and conversions between analog and digital signals for CDMA, AMPS (FM), and GPS operation. For a given operation, the CX20529 accepts analog baseband In-phase (I) and Quadrature-phase (Q) signals, performs channel selection low-pass filtering, and converts the analog baseband signals into digital signals. For clock generation, the CX20529 includes internal digital and Phase-Locked Loop (PLL) clock synthesis for 19.2, 19.68, and 19.8 MHz system clocks. The device also provides the capability to generate or to accept the CHIPx8 clock to or from the Mobile Station Modem (MSM) or equivalent baseband device. The CX20529 also integrates a VHF PLL synthesizer to synthesize the receive Intermediate Frequency (IF).

The CX20529 is characterized for operation from a power supply voltage range of 2.7 V to 3.4 V, with power control logic maintaining a minimum power consumption. Electrical performance parameters are designed to operate over the  $-30\text{ }^{\circ}\text{C}$  to  $+85\text{ }^{\circ}\text{C}$  range. The device is available in 40-pin 6 x 6 mm Land Grid Array (LGA) package. A system block diagram of the CX20529 is shown in Figure 1.

## Product Summary | CX20529

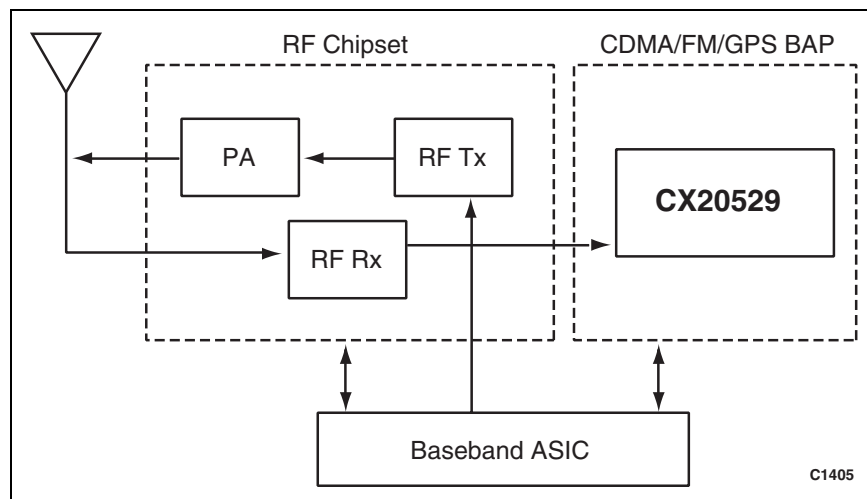

Figure 1. CX20529 System Block Diagram

## Ordering Information

Model Name	Manufacturing Part Number	Product Revision
CX20529 Baseband Analog Processor	CX20529-12	

DataSheet4U.com

© 2002, 2003 Skyworks Solutions, Inc. All Rights Reserved.

Information in this document is provided in connection with Skyworks Solutions, Inc. ("Skyworks") products. These materials are provided by Skyworks as a service to its customers and may be used for informational purposes only. Skyworks assumes no responsibility for errors or omissions in these materials. Skyworks may make changes to its products, specifications and product descriptions at any time, without notice. Skyworks makes no commitment to update the information and shall have no responsibility whatsoever for conflicts, incompatibilities, or other difficulties arising from future changes to its products and product descriptions.

No license, express or implied, by estoppel or otherwise, to any intellectual property rights is granted by this document. Except as may be provided in Skyworks' Terms and Conditions of Sale for such products, Skyworks assumes no liability whatsoever.

THESE MATERIALS ARE PROVIDED "AS IS" WITHOUT WARRANTY OF ANY KIND, EITHER EXPRESS OR IMPLIED, RELATING TO SALE AND/OR USE OF SKYWORKS™ PRODUCTS INCLUDING WARRANTIES RELATING TO FITNESS FOR A PARTICULAR PURPOSE, MERCHANTABILITY, PERFORMANCE, QUALITY OR NON-INFRINGEMENT OF ANY PATENT, COPYRIGHT OR OTHER INTELLECTUAL PROPERTY RIGHT. SKYWORKS FURTHER DOES NOT WARRANT THE ACCURACY OR COMPLETENESS OF THE INFORMATION, TEXT, GRAPHICS OR OTHER ITEMS CONTAINED WITHIN THESE MATERIALS. SKYWORKS SHALL NOT BE LIABLE FOR ANY SPECIAL, INDIRECT, INCIDENTAL, OR CONSEQUENTIAL DAMAGES, INCLUDING WITHOUT LIMITATION, LOST REVENUES OR LOST PROFITS THAT MAY RESULT FROM THE USE OF THESE MATERIALS.

Skyworks™ products are not intended for use in medical, lifesaving or life-sustaining applications. Skyworks' customers using or selling Skyworks™ products for use in such applications do so at their own risk and agree to fully indemnify Skyworks for any damages resulting from such improper use or sale.

The following are trademarks of Skyworks Solutions, Inc.: Skyworks™, the Skyworks symbol, SPR™, Single Package Radio™, and "Breakthrough Simplicity"™. Product names or services listed in this publication are for identification purposes only, and may be trademarks of third parties. Third-party brands and names are the property of their respective owners.

Additional information, posted at [www.skyworksin.com](http://www.skyworksin.com), is incorporated by reference.

General Information  
Skyworks Solutions, Inc.  
20 Sylvan Rd.  
Woburn, MA 01801

[www.skyworksin.com](http://www.skyworksin.com)

