

- RATED 1W OUTPUT
- HIGH POWER DENSITY
- 7PIN SIP /14PIN DIP PACKAGE
- DUAL OUTPUT
- INDUSTRIAL STANDARD PIN-OUT
- NO HEAT SINK REQUIRED
- 3KVAC ISOLATION
- FIXED INPUT
- UNREGULATED OUTPUT
- PCB MOUNTING

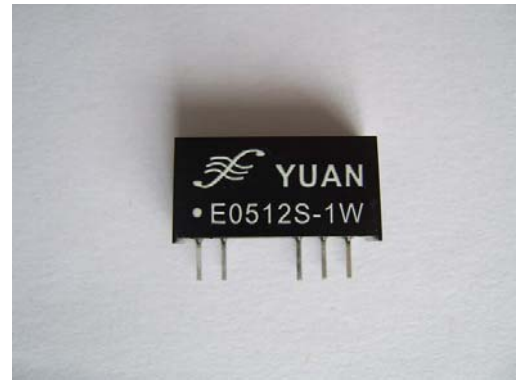

## ELECTRICAL SPECIFICATIONS

All specifications tested typically @ 25°C, humidity<75%, nominal input and rated output unless otherwise noted.

### OUTPUT SPECIFICATIONS

Items:	Testing condition	Min	Typ	Max
Output accuracy:	At full load and nominal Vin			±5%
Output power:		0.1W	1W	1W
Line regulation:	For Vin change of 1%			1.2
Load regulation:	From 20% to full load		10%	15%
Ripple and noise:	20MHz bandwidth			150 mV p-p
Temperature drift:				±0.02 %/°C
Minimum load				10%
Switching frequency			100KHz	
Over load protection	% of FL at nominal input		120	
Short circuit protection		Momentary		

### INPUT SPECIFICATIONS

Items:	Testing condition	Min	Typ	Max
Input voltage range	3.3 VDC nominal input		3-3.6	
	5 VDC nominal input		4.5-5.5	
	9 VDC nominal input		8.1-9.9	
	12VDC nominal input		10.8-13.2	
	15 VDC nominal input		13.5-16.5	
	24VDC nominal input		21.6-26.4	

COMMON SPECIFICATIONS				
Items		Min	Typ.	Max
Operating temperature range		-40°C		+85°C
Storage temperature range		-55°C		+125°C
Humidity				<90%
Cooling	Free Air Convection			
Isolation voltage (VDC)	Input to Output		1,000	
Isolation resistance (ohms)			10 <sup>9</sup>	
Isolation capacitance (pF)				30
Efficiency (%)	See Product List	72	80	
Case material	Non-conductive black plastic			
Potting material	Epoxy Resin UL94-V0			
Packing material	Tube			
Dimension (mm / inch) (L*W*H)	SIP: 19.5*6.00*9.50 (0.76*0.24*0.37) DIP: 20.4*10*8.2(0.80*0.39*0.32)			
Weight (g)	2			
MTBF (Hrs)	>1,000,000			

PRODUCT LIST								
Part Number	Input Voltage (VDC)			Output		Efficiency (%, Typ.)	Package	Capacitor Load Max (uF)
	Range	Nominal	Max.	Current (mA)	Voltage (VDC)			
E0505S/D-1W	4.5-5.5	5	5.5	±100	±5	71	SIP/DIP	4.7
E0512S/D-1W	4.5-5.5	5	5.5	±42	±12	80	SIP/DIP	1
E0515S/D-1W	4.5-5.5	5	5.5	±34	±15	80	SIP/DIP	0.47
E1205S/D-1W	10.8-13.2	12	13.2	±100	±5	80	SIP/DIP	4.7
E1212S/D-1W	10.8-13.2	12	13.2	±42	±12	78	SIP/DIP	1
E2403S/D-1W	21.6-26.4	24	26.4	±150	±3.3	75	SIP/DIP	4.7
E2405S/D-1W	21.6-26.4	24	26.4	±100	±5	74	SIP/DIP	4.7
E2412S/D-1W	21.6-26.4	24	26.4	±42	±12	76	SIP/DIP	1

## CONNECTING DC-DC CONVERTERS IN SERIES

www.DataSheet4U.com

Galvanic isolation of the output allows multiple converters to be connected in series simply by connecting the positive output of one converter to the negative of another (see figure 1). In this way, non-standard voltage rails can be generated, however, the current output of the highest output voltage converter should not be exceeded. When converters are connected in series, additional filtering is strongly recommended as the converters switching circuits are not synchronized. As well as a summation of the ripple voltages, the output could also produce relatively large beat frequencies. A capacitor across the output will help, as will a series inductor.

## CONNECTING DC-DC CONVERTERS IN PARALLEL

If the available power output from a single converter is inadequate for the application, then multiple converters can be paralleled to produce a higher output power. However, it is not recommended to parallel converters to generate a higher power output, please select our higher power output modules or contact us for a customized solution.

It should be noted that it is always preferable to parallel multiple converters of the same type. For instance, if a 2.5W converter is required, then either 2pcs AxxxxS-2W should be used or 3 AxxxxS-1W, not an AxxxxS-2W and an AxxxxS-1W. The reason for this is that the output voltages are not sufficiently well matched to guarantee that an AxxxxS-2W would supply twice as much as an AxxxxS-1W and the situation would occur where there was only 1W being drawn from the AxxxxS-2W and 1.5W from AxxxxS-1W. Even with paralleled converters of the same type, loading will be uneven, however, there is only likely to be around a 10% difference in output load when the output voltages are well matched.

When connecting converter outputs, it should be remembered that the switching will not be synchronous, hence some form of coupling should be employed. One possible solution is to use a diode feed, this is suitable mainly for 12V and 15V output types only where the diode voltage drop (typically 0.6V) will not significantly affect the circuit functionality (see figure 2). With 5V and 9V supplies the diode drop is generally too large to consider as a suitable means of connecting paralleled converters. This method also has a beat frequency that will superimpose itself over the ripple of the two converters, this can be reduced by using an external capacitor at the paralleled output. The preferred method of connecting converters in parallel is via series inductors on the output (see figure 3). This configuration not only has a lower loss of voltage than the diode method, but by suitable choice of inductor and an additional external capacitor, the beat frequency can be significantly reduced, as will the ripple from each converter. Suitable values are given in the table below (see table 1), these typically reduce the beat and ripple frequencies by a factor of 10.

## ISOLATION

One of the main features of the majority of Sunyuan components DC-DC converters is the high galvanic isolation capability. This allows several variations on circuit topography by using a single DC-DC converter. The basic input to output isolation can be used to provide either a simple isolated output power source, or to generate different voltage rails and /or dual polarity rails. These configurations are most often found in data processing, instrumentation and other noise sensitive circuits where it is necessary to isolate the load and noise presented to the local power supply rails from that of an entire system. Usually local supply noise appears as common mode noise at the converter and does not pollute the main system power supply rails. The isolated positive output can be connected to the input ground rail to generate a negative supply rail if required. Since the output is isolated from the input the choice of reference for the output side can be relatively arbitrary, for example an additional single rail can be generated above the main supply rail or offset by some other DC value.

Regulated converters need more consideration than the unregulated type for mixing the reference level. Essentially the single supply rail has a regulator in its positive output rail only, hence referring the isolated ground will only work if all the current return is through the DC-DC and not via other external components, such as diode bias, resistor feed. Have an alternative return path can upset the regulation and the performance of the system may not equal that of the converter. In one word, the isolation features are to generate two completely independent power supply but also united perfectly through the modern technology. This has been widely used in the application of mixed circuits, A/D, D/A and other circuits that are sensitive to noise.

## FILTERING

All Sunyuan isolated DC-DC Converters have a fixed characteristic frequency at which the device operates. This fixed frequency allows filtering that is relatively simple compared to pulse-skipping types. In a pulse-skipping converter a large range of frequencies are encountered as the device adjusts the pulse interval for loading conditions.

**NOMENCLATURE**

**E0505 S/D - 1W**

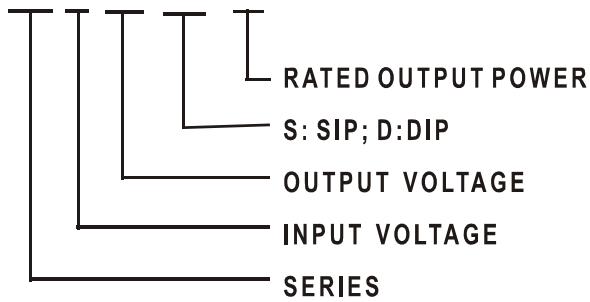

**TEMPERATURE DERATING GRAPH**

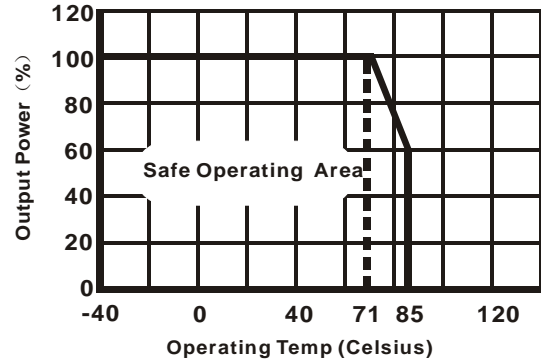

**TYPICAL CONNECTION**

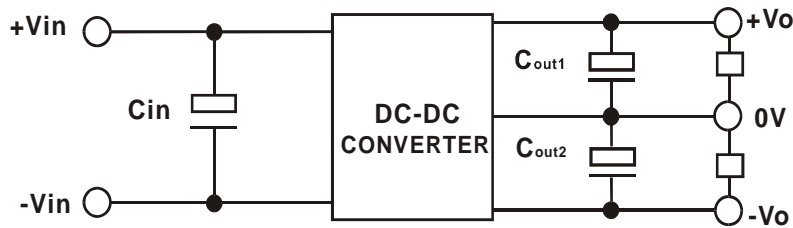

**OUTLINE DIMENSION**

SIZE	SIP(LxWxH)	DIP(LxWxH)
1W	19.6x6.0x10	20.4x10x6.5
2W	19.6x7.0x10	20.4x10x6.5

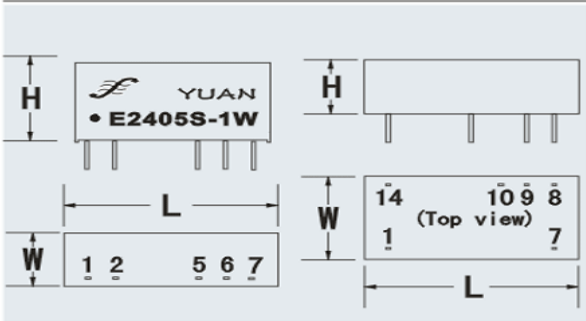

PKG	Vin	GND	-Vo	0V	+Vo
ES	1	2	5	6	7
ED	14	1	10	9	8

Note: NC Pin can't be connected to any external circuit.

**PINS DESCRIPTION**

SIP	Connection		DIP
	Pin	Function	
1	+Vin	Input	14
2	GND	Input	1
5	-Vo	Output	10
6	0V	Common	9
7	+Vo	Output	8
		NC	7

SHENZHEN SUNYUAN TECHNOLOGY CO., LTD.

3F, 3Bldg, Duoli Industrial Zone,

Meihua Rd. Futian District,

Shenzhen 518049, China

Tel: +86-755-83100080

Fax: +86-755-83116652

Email: info@szyuan.com

www.szyuan.com

www.DataSheet4U.com