

1.5-W Mono Filterless Class-D Audio Power Amplifier

DESCRIPTION

The EUA2005 is a high efficiency, 1.5W mono class-D audio power amplifier. A low noise, filterless PWM architecture eliminates the output filter, reducing external component count, system cost, and simplifying design.

Operating in a single 5V supply, EUA2005 is capable of driving 8Ω speaker load at a continuous average output of 1.5W/10% THD+N or 1.3W/1% THD+N. The EUA2005 has high efficiency with speaker load compared to a typical class AB amplifier. With a 3.6V supply driving an 8Ω speaker, the efficiency for a 400mW power level is 84%.

In cellular handsets, the earpiece, speaker phone, and melody ringer can each be driven by the EUA2005. The gain of EUA2005 is externally configurable which allows independent gain control from multiple sources by summing signals from separate sources.

The EUA2005 is available in DFN packages.

FEATURES

- Efficiency at 3.6V With an 8-Ω Speaker:
 - 84% at 400 mW
 - 80% at 100 mW
- Low 2.8-mA Quiescent Current and 0.5-μA Shutdown Current
- 2.5V to 5.5V Wide Supply Voltage
- Optimized PWM Output Stage Eliminates LC Output Filter
- Improved PSRR (–72 dB) Eliminates Need for a Voltage Regulator
- Fully Differential Design Reduces RF Rectification and Eliminates Bypass Capacitor
- Improved CMRR Eliminates Two Input Coupling Capacitors
- Internally Generated 250-kHz Switching Frequency
- Integrated Pop and Click Suppression Circuitry
- 3mm × 3mm DFN-8 package
- RoHS compliant and 100% lead(Pb)-free

APPLICATIONS

- Ideal for Wireless or Cellular Handsets and PDAs

Typical Application Circuit

www.DataSheet4U.com

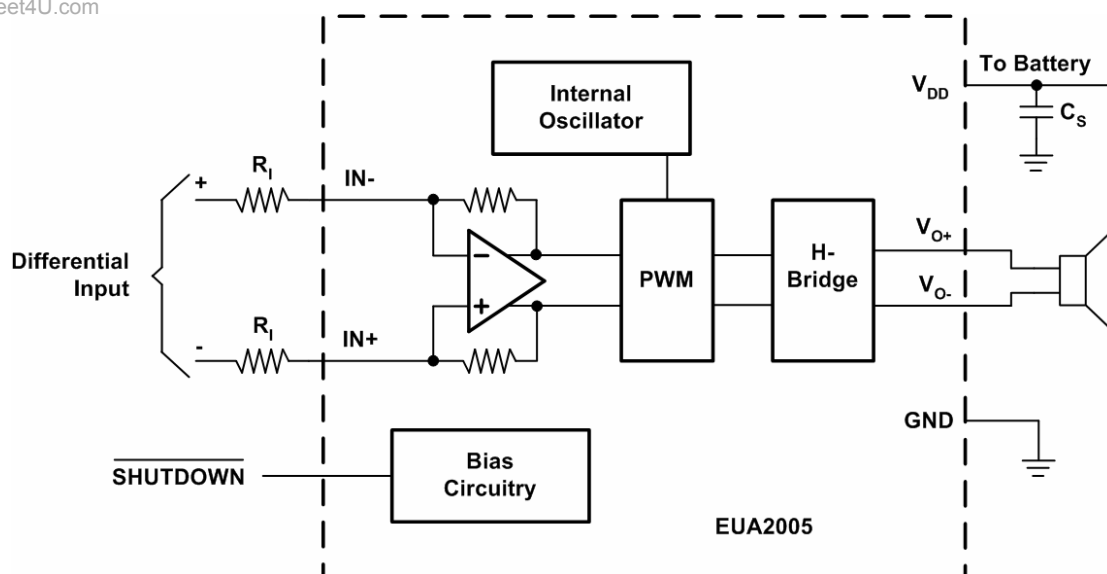
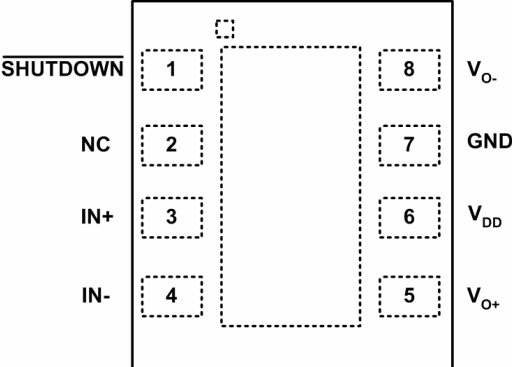

Figure1.

Pin Configurations

Part Number	Pin Configurations
EUA2005 DFN-8	<p style="text-align: center;">TOP VIEW</p>  <p style="text-align: center;"> SHUTDOWN 1 8 V_{O-} </p> <p style="text-align: center;"> NC 2 7 GND </p> <p style="text-align: center;"> IN+ 3 6 V_{DD} </p> <p style="text-align: center;"> IN- 4 5 V_{O+} </p>

Pin Description

PIN	DFN-8	I/O	DESCRIPTION
$\overline{\text{SHUTDOWN}}$	1	I	Shutdown terminal (active low logic)
NC	2		No internal connection
IN+	3	I	Positive differential input
IN-	4	I	Negative differential input
V_{O+}	5	O	Positive BTL output
V_{DD}	6	I	Power supply
GND	7	I	High-current ground
V_{O-}	8	O	Negative BTL output

Ordering Information

Order Number	Package Type	Marking	Operating Temperature range
EUA2005JIR1	DFN-8	XXXX 2005A	-40 °C to 85°C

EUA2005

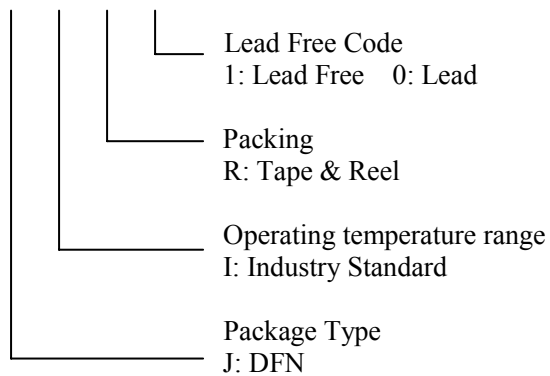

Absolute Maximum Ratings

Supply Voltage, V_{DD}	-0.3 V to 6V
Voltage at Any Input Pin	-0.3 V to $V_{DD} + 0.3V$
Junction Temperature, T_{JMAX}	150°C
Storage Temperature Rang, T_{stg}	-65°C to 150°C
ESD Susceptibility	2kV
Lead temperature 1,6 mm (1/16 inch) from case for 10 seconds	260°C
Thermal Resistance	
θ_{JA} (DFN)	47°C/W

Recommended Operating Conditions

		Min	Max	Unit
Supply voltage, V_{DD}		2.5	5.5	V
High-level input voltage, V_{IH}	SHUTDOWN	1.6	V_{DD}	V
Low-level input voltage, V_{IL}	SHUTDOWN	0	0.35	V
Input resistor, R_I	Gain $\leq 20V/V$ (26dB)	15		k
Common mode input voltage range, V_{IC}	$V_{DD}=2.5V, 5.5V, CMRR \leq -49dB$	0.5	$V_{DD}-0.8$	V
Operating free-air temperature, T_A		-40	85	°C

Electrical Characteristics $T_A = 25^\circ C$ (Unless otherwise noted)

Symbol	Parameter	Conditions	EUA2005			Unit
			Min	Typ	Max.	
$ V_{OS} $	Output offset voltage (measured differentially)	$V_I = 0V, A_V = 2 V/V, V_{DD} = 2.5V$ to 5.5V		1	25	mV
PSRR	Power supply rejection ratio	$V_{DD} = 2.5V$ to 5.5V		-72	-55	dB
CMRR	Common mode rejection ratio	$V_{DD} = 2.5V$ to 5.5V, $V_{IC} = V_{DD}/2$ to 0.5V, $V_{IC} = V_{DD}/2$ to $V_{DD} - 0.8V$		-60	-48	dB
$ I_{IH} $	High-level input current	$V_{DD} = 5.5V, V_I = 5.8V$			100	μA
$ I_{IL} $	Low-level input current	$V_{DD} = 5.5V, V_I = -0.3V$			5	μA
$I_{(Q)}$	Quiescent current	$V_{DD} = 5.5V$, no load		4.3	4.9	mA
		$V_{DD} = 3.6V$, no load		2.8		
		$V_{DD} = 2.5V$, no load		2	3.2	
$I_{(SD)}$	Shutdown current	$V(\text{SHUTDOWN}) = 0.35V, V_{DD} = 2.5V$ to 5.5V		0.5	2	μA
$r_{DS(on)}$	Static drain-source on-state resistance	$V_{DD} = 2.5V$		700		m Ω
		$V_{DD} = 3.6V$		500		
		$V_{DD} = 5.5V$		400		
	Output impedance in SHUTDOWN	$V(\text{SHUTDOWN}) = 0.4V$		>1		k Ω
$f_{(sw)}$	Switching frequency	$V_{DD} = 2.5V$ to 5.5V	200	250	300	kHz
	Resistance from shutdown to GND			300		k Ω

Electrical Characteristics $T_A = 25^\circ\text{C}$, Gain= 2V/V, $R_L=8\Omega$ (Unless otherwise noted)

Symbol	Parameter	Conditions	EUA2005			Unit
			Min	Typ	Max.	
P_O	Output power	THD+N=10%, f=1kHz, $R_L=8\Omega$	$V_{DD}= 5V$		1.52	W
			$V_{DD}= 3.6V$		0.79	
			$V_{DD}= 2.5V$		0.39	
		THD+N=1%, f=1kHz, $R_L=8\Omega$	$V_{DD}= 5V$		1.30	W
			$V_{DD}= 3.6V$		0.64	
			$V_{DD}= 2.5V$		0.30	
THD+N	Total harmonic distortion plus noise	$V_{DD}= 5V, P_O=1W, R_L=8\Omega, f=1kHz$		0.28		%
		$V_{DD}= 3.6V, P_O=0.5W, R_L=8\Omega, f=1kHz$		0.30		
		$V_{DD}= 2.5V, P_O=200mW, R_L=8\Omega, f=1kHz$		0.28		
kSVR	Supply ripple rejection ratio	$V_{DD}= 3.6V$, Inputs ac-grounded with $C_I= 2\mu F$	f=217 Hz, $V_{(RIPPLE)}=200mV_{pp}$		-60	dB
SNR	Signal-to-noise ratio	$V_{DD}= 5V, P_O=1W, R_L=8\Omega$			84	dB
V_n	Output voltage noise	$V_{DD}= 3.6V$, f=20Hz to 20kHz, Inputs ac-grounded with $C_I= 2\mu F$	No weighting		157	μV_{RMS}
			A weighting		117	
CMRR	Common mode rejection ratio	$V_{DD}= 3.6V$, $V_{IC}=1 V_{PP}$	f=217 Hz		-55	dB
Z_I	Start-up time from shutdown	$V_{DD}= 3.6V$			11.5	ms

Typical Operating Characteristics

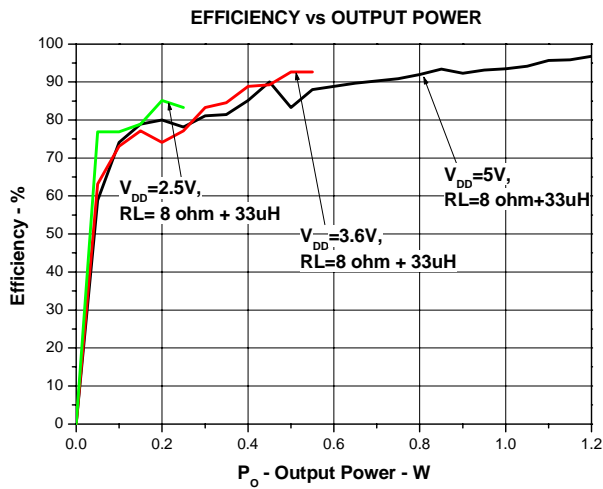

Figure2.

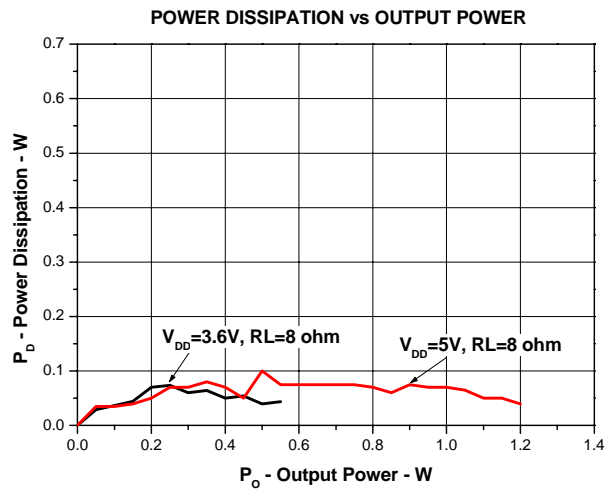

Figure3.

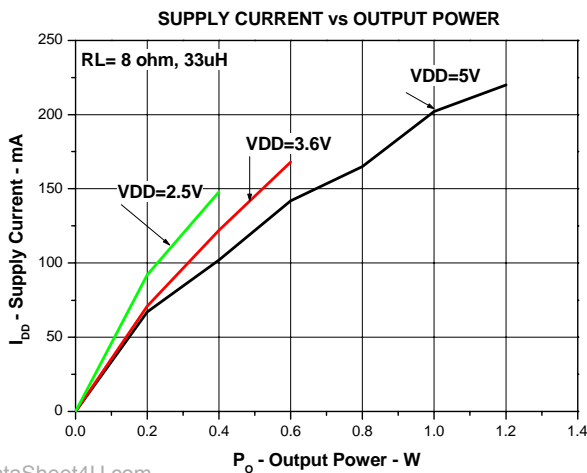

Figure4.

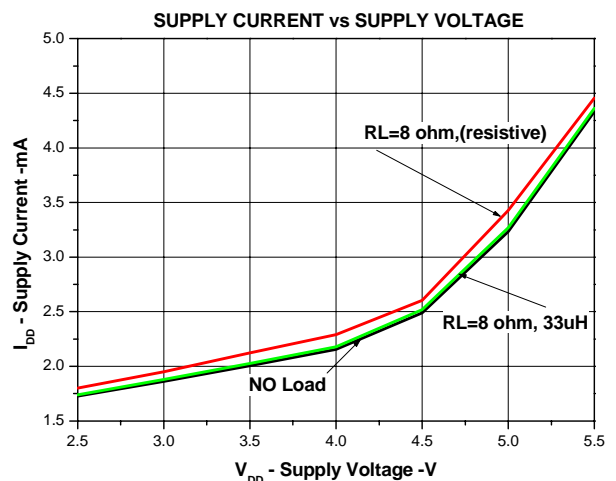

Figure5.

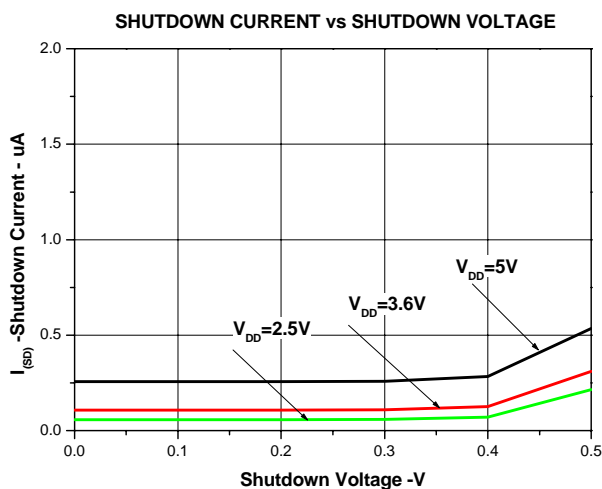

Figure6.

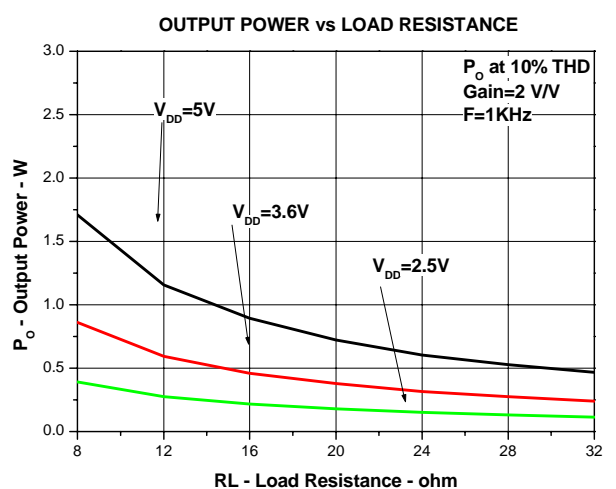

Figure7.

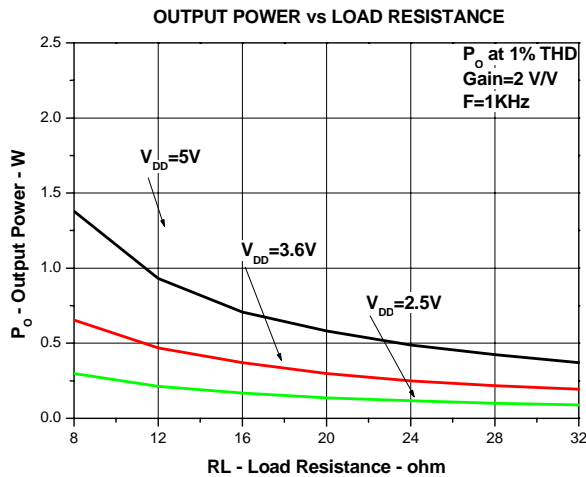

Figure8.

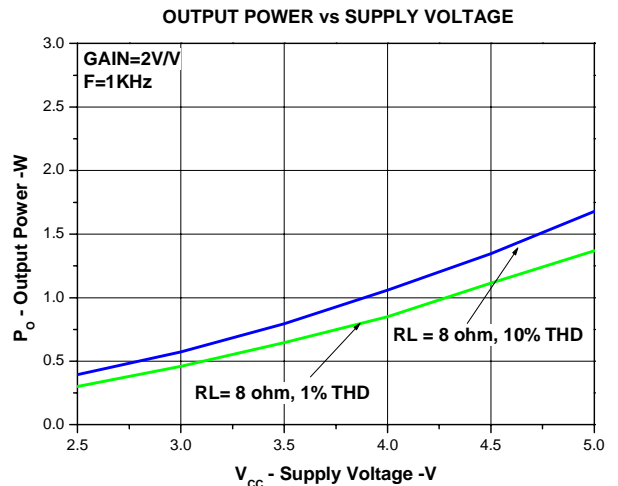

Figure9.

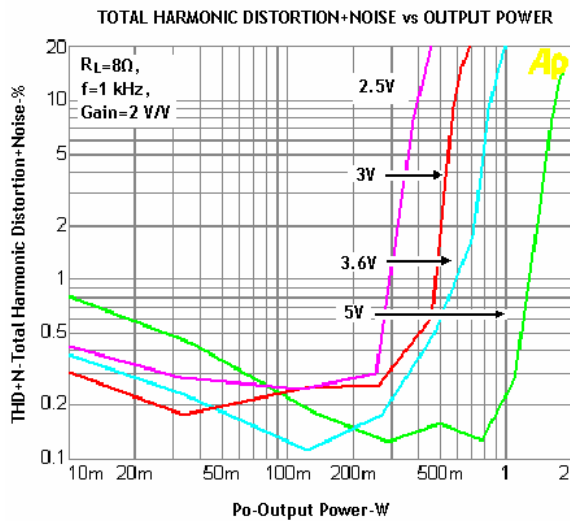

Figure10.

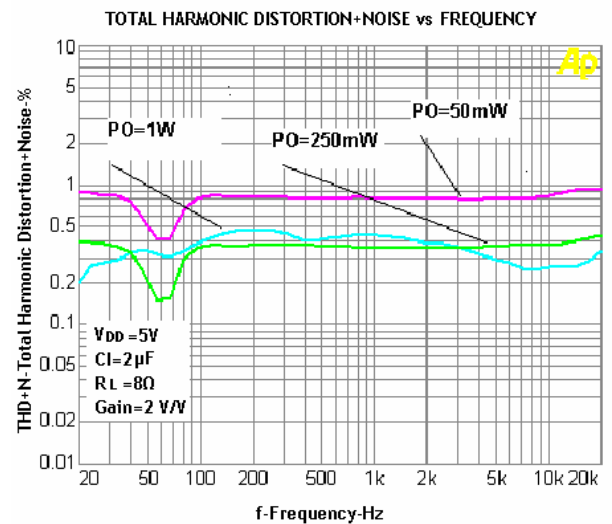

Figure11.

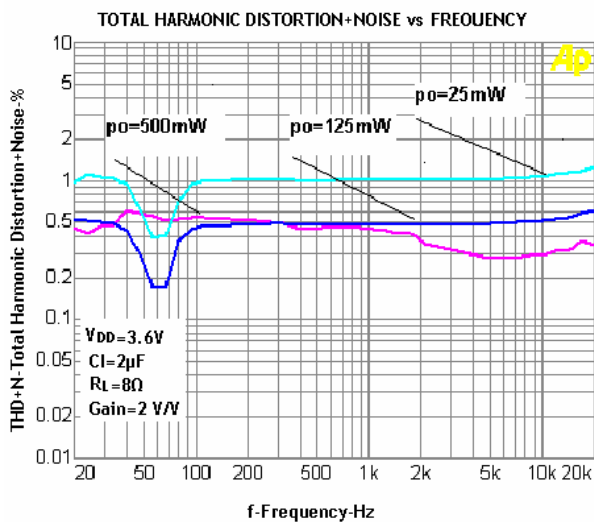

Figure12.

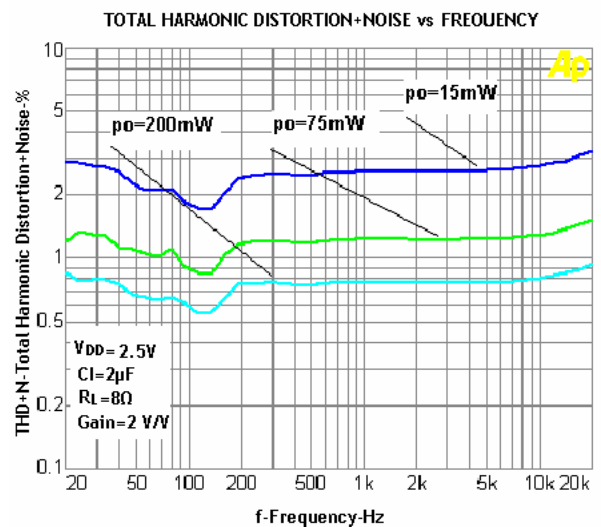

Figure13.

TOTAL HARMONIC DISTORTION+NOISE vs COMMON MODE INPUT VOLTAGE

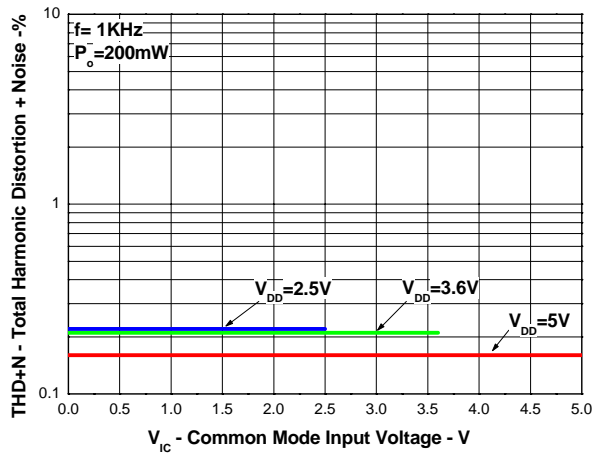

Figure14.

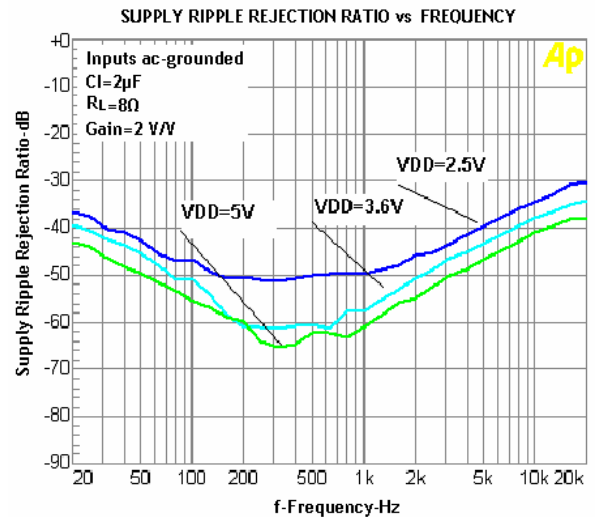

Figure15.

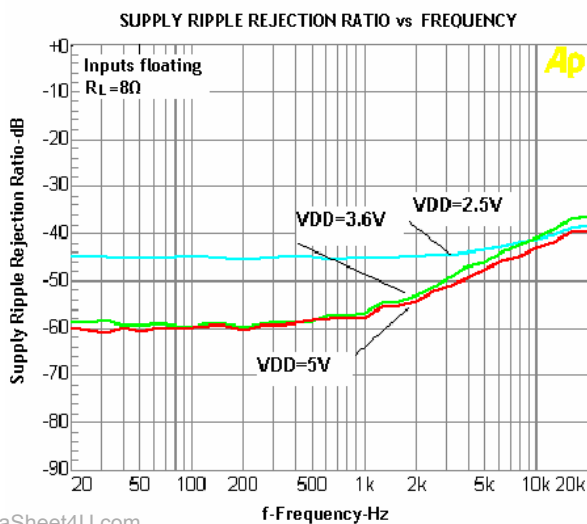

Figure16.

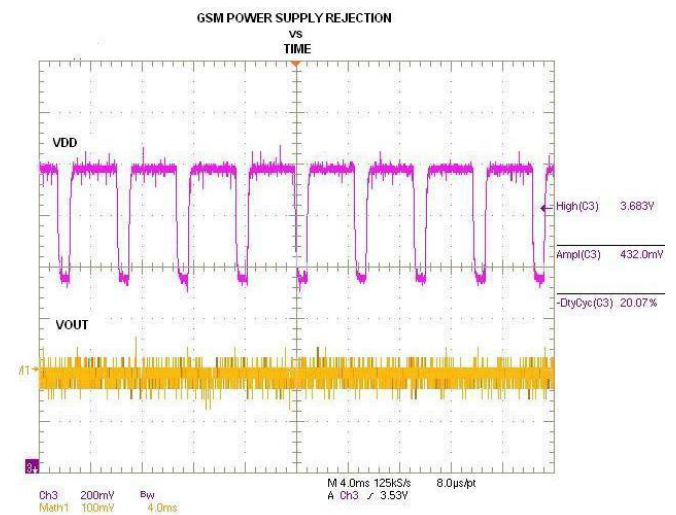

Figure17.

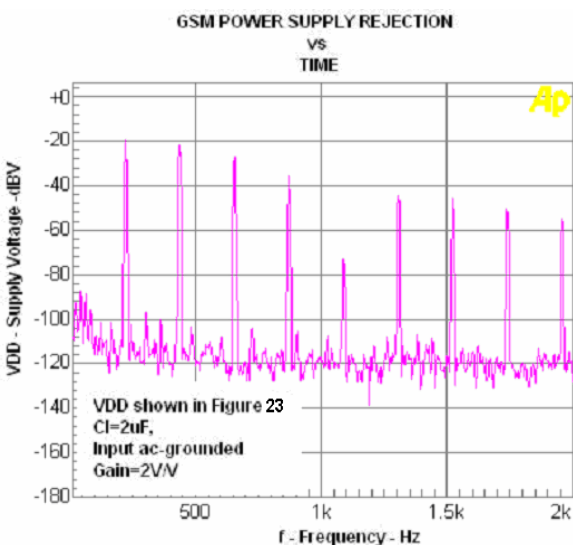

Figure18.

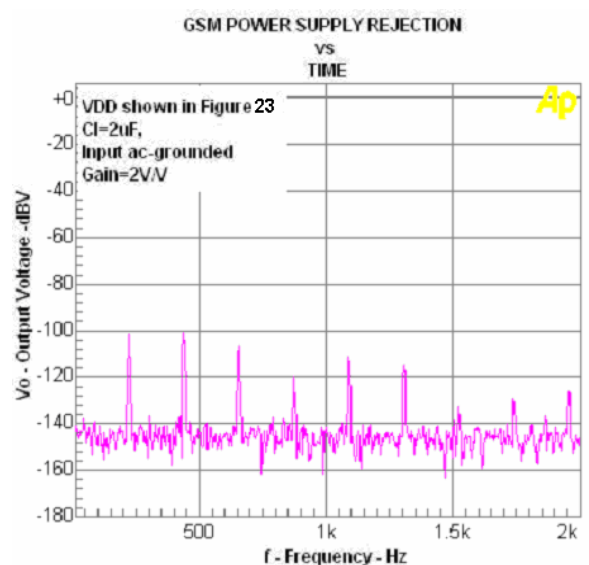

Figure19.

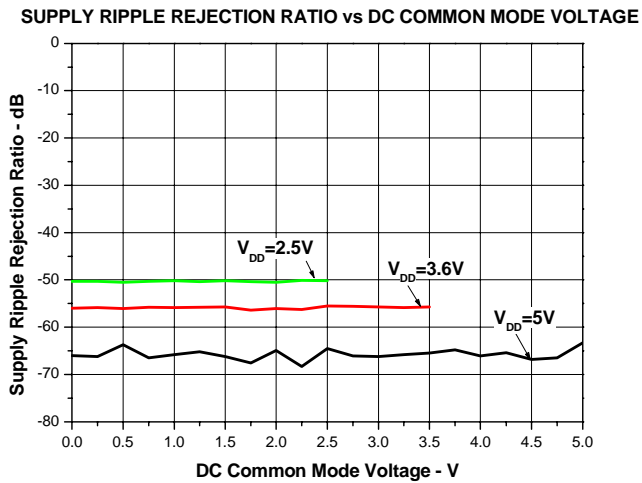

Figure20.

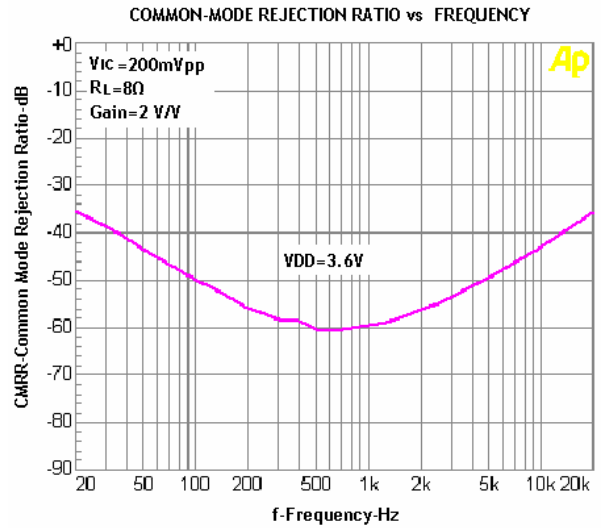

Figure21.

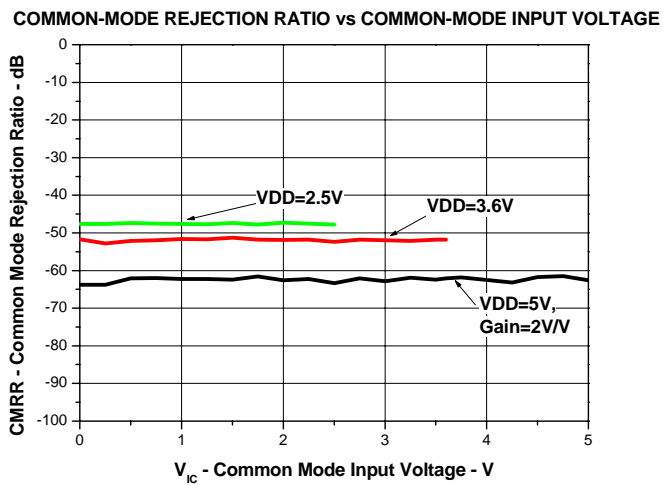

Figure22.

Application Information

Fully Differential Amplifier

The EUA2005 is a fully differential amplifier with differential inputs and outputs. The fully differential amplifier consists of a differential amplifier and a common-mode amplifier. The differential amplifier ensures that the amplifier outputs a differential voltage on the output that is equal to the differential input times the gain. The common-mode feedback ensures that the common-mode voltage at the output is biased around $V_{DD}/2$ regardless of the common-mode voltage at the input. The fully differential EUA2005 can still be used with a single-ended input; however, the EUA2005 should be used with differential inputs when in a noisy environment, like a wireless handset, to ensure maximum noise rejection.

Advantages of Fully Differential Amplifiers

- Input-coupling capacitors not required:
 - The fully differential amplifier allows the inputs to be biased at voltage other than mid-supply. For example, if a codec has a midsupply lower than the midsupply of the EUA2005, the common-mode feedback circuit will adjust, and the EUA2005 outputs will still be biased at midsupply of the EUA2005. The inputs of the EUA2005 can be biased from 0.5V to $V_{DD} - 0.8$ V. If the inputs are biased outside of that range, input-coupling capacitors are required.
- Midsupply bypass capacitor, $C_{(BYPASS)}$, not required:
 - The fully differential amplifier does not require a bypass capacitor. This is because any shift in the midsupply affects both positive and negative channels equally and cancels at the differential output.
- Better RF-immunity:
 - GSM handsets save power by turning on and shutting off the RF transmitter at a rate of 217 Hz. The transmitted signal is picked-up on input and output traces. The fully differential amplifier cancels the signal much better than the typical audio amplifier.

Component Selection

Figure 23 shows the EUA2005 typical schematic with differential inputs and Figure 24 shows the EUA2005 with differential inputs and input capacitors, and Figure 25 shows the EUA2005 with single-ended inputs. Differential inputs should be used whenever possible because the single-ended inputs are much more susceptible to noise.

Table 1. Typical Component Values

REF DES	VALUE
R_I	150k Ω ($\pm 0.5\%$)
C_S	1 μ F (+22%,-80%)
C_1 (1)	3.3nF ($\pm 10\%$)

(1) C_1 is only needed for single-ended input or if V_{ICM} is not between 0.5 V and $V_{DD} - 0.8$ V. $C_1 = 3.3$ nF (with $R_I = 150$ k Ω) gives a high-pass corner frequency of 321 Hz.

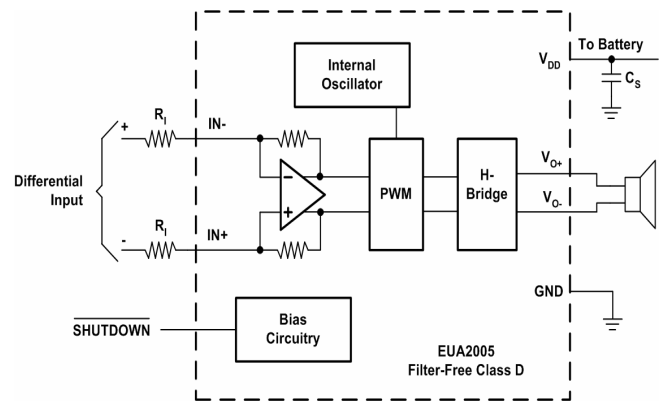

Figure 23. Typical Application Schematic With Differential Input for a Wireless Phone

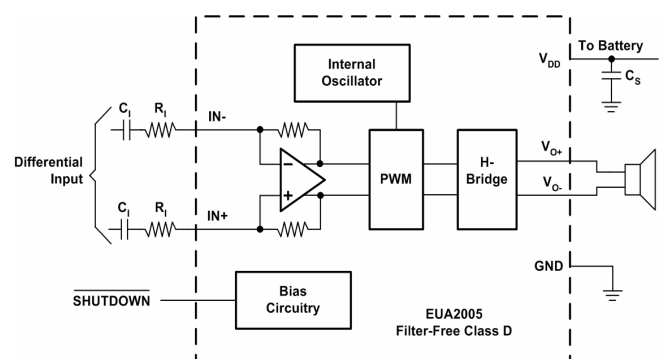

Figure 24. Typical Application Schematic With Differential Input and Input Capacitors

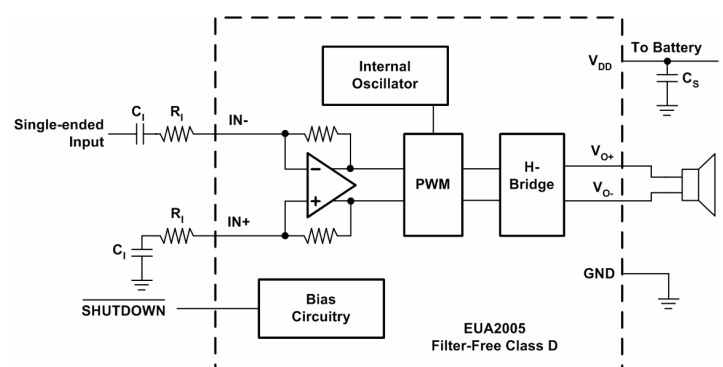

Figure 25. Typical Application Schematic With Single-Ended Input

Input Resistors (R_I)

The input resistors (R_I) set the gain of the amplifier according to equation (1).

$$\text{Gain} = \frac{2 \times 150\text{k}\Omega}{R_I} \left(\frac{\text{V}}{\text{V}} \right) \text{-----}(1)$$

Resistor matching is very important in fully differential amplifiers. The balance of the output on the reference voltage depends on matched ratios of the resistors. CMRR, PSRR, and cancellation of the second harmonic distortion diminish if resistor mismatch occurs. Therefore, it is recommended to use 1% tolerance resistors or better to keep the performance optimized. Matching is more important than overall tolerance. Resistor arrays with 1% matching can be used with a tolerance greater than 1%.

Place the input resistors very close to the EUA2005 to limit noise injection on the high-impedance nodes.

For optimal performance the gain should be set to 2 V/V or lower. Lower gain allows the EUA2005 to operate at its best, and keeps a high voltage at the input making the inputs less susceptible to noise.

Decoupling Capacitor (C_S)

The EUA2005 is a high-performance class-D audio amplifier that requires adequate power supply decoupling to ensure the efficiency is high and total harmonic distortion (THD) is low. For higher frequency transients, spikes, or digital hash on the line, a good low equivalent-series-resistance (ESR) ceramic capacitor, typically 1 μF , placed as close as possible to the device V_{DD} lead works best. Placing this decoupling capacitor close to the EUA2005 is very important for the efficiency of the class-D amplifier, because any resistance or inductance in the trace between the device and the capacitor can cause a loss in efficiency. For filtering lower-frequency noise signals, a 10 μF or greater capacitor placed near the audio power amplifier would also help, but it is not required in most applications because of the high PSRR of this device.

Input Capacitors (C_I)

The EUA2005 does not require input coupling capacitors if the design uses a differential source that is biased from 0.5 V to $V_{DD} - 0.8$ V (shown in Figure 23). If the input signal is not biased within the recommended common-mode input range, if needing to use the input as a high pass filter (shown in Figure 24), or if using a single-ended source (shown in Figure 25), input coupling capacitors are required.

The input capacitors and input resistors form a high-pass filter with the corner frequency, f_c , determined in equation (2).

$$f_c = \frac{1}{(2\pi R_I C_I)} \text{-----}(2)$$

The value of the input capacitor is important to consider as it directly affects the bass (low frequency) performance of the circuit. Speakers in wireless phones cannot usually respond well to low frequencies, so the corner frequency can be set to block low frequencies in this application.

Equation (3) is reconfigured to solve for the input coupling capacitance.

$$C_I = \frac{1}{(2\pi R_I f_c)} \text{-----}(3)$$

If the corner frequency is within the audio band, the capacitors should have a tolerance of $\pm 10\%$ or better, because any mismatch in capacitance causes an impedance mismatch at the corner frequency and below.

For a flat low-frequency response, use large input coupling capacitors (1 μF). However, in a GSM phone the ground signal is fluctuating at 217 Hz, but the signal from the codec does not have the same 217 Hz fluctuation. The difference between the two signals is amplified, sent to the speaker, and heard as a 217 Hz hum.

Summing Input Signals

Most wireless phones or PDAs need to sum signals at the audio power amplifier or just have two signal sources that need separate gain. The EUA2005 makes it easy to sum signals or use separate signal sources with different gains. Many phones now use the same speaker for the earpiece and ringer, where the wireless phone would require a much lower gain for the phone earpiece than for the ringer. PDAs and phones that have stereo headphones require summing of the right and left channels to output the stereo signal to the mono speaker.

Summing Two Differential Input Signals

Two extra resistors are needed for summing differential signals (a total of 5 components). The gain for each input source can be set independently (see equations (4) and (5), and Figure 26).

$$\text{Gain}_1 = \frac{V_O}{V_{I1}} = \frac{2 \times 150\text{k}\Omega}{R_{I1}} \left(\frac{V}{V} \right) \text{-----(4)}$$

$$\text{Gain}_2 = \frac{V_O}{V_{I2}} = \frac{2 \times 150\text{k}\Omega}{R_{I2}} \left(\frac{V}{V} \right) \text{-----(5)}$$

If summing left and right inputs with a gain of 1 V/V, use $R_{I1} = R_{I2} = 300\text{ k}$.

If summing a ring tone and a phone signal, set the ring-tone gain to $\text{Gain}_2 = 2\text{ V/V}$, and the phone gain to $\text{Gain}_1 = 0.1\text{ V/V}$. The resistor values would be...

$R_{I1}=3\text{M}$, and $R_{I2}=150\text{k}$

Summing a Differential Input Signal and a Single-Ended Input Signal

Figure 27 shows how to sum a differential input signal and a single-ended input signal. Ground noise can couple in through $IN+$ with this method. It is better to use differential inputs. The corner frequency of the single-ended input is set by C_{I2} , shown in equation (8). To assure that each input is balanced, the single-ended input must be driven by a low-impedance source even if the input is not in use

$$\text{Gain}_1 = \frac{V_O}{V_{I1}} = \frac{2 \times 150\text{k}\Omega}{R_{I1}} \left(\frac{V}{V} \right) \text{----- (6)}$$

$$\text{Gain}_2 = \frac{V_O}{V_{I2}} = \frac{2 \times 150\text{k}\Omega}{R_{I2}} \left(\frac{V}{V} \right) \text{-----(7)}$$

$$C_{I2} = \frac{1}{(2\pi R_{I2} f_{c2})} \text{-----(8)}$$

If summing a ring tone and a phone signal, the phone signal should use a differential input signal while the ring tone might be limited to a single-ended signal. Phone gain is set at $\text{gain}_1 = 0.1\text{ V/V}$, and the ring-tone gain is set to $\text{gain}_2 = 2\text{ V/V}$, the resistor values would be...

$R_{I1}=3\text{M}$, and $R_{I2}=150\text{k}$

The high pass corner frequency of the single-ended input is set by C_{I2} . If the desired corner frequency is less than 20 Hz...

$$C_{I2} > \frac{1}{(2\pi 150\text{k}\Omega 20\text{Hz})} \text{-----(9)}$$

$$C_{I2} > 53\text{pF} \text{-----(10)}$$

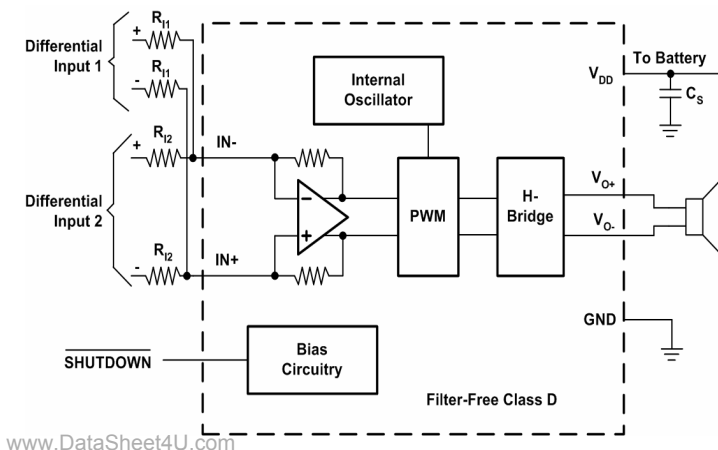

Figure 26. Application Schematic With EUA2005 Summing Two Differential Inputs

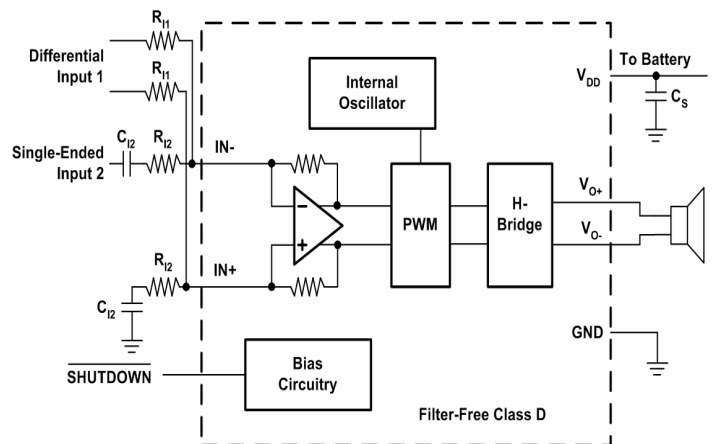

Figure 27. Application Schematic With EUA2005 Summing Input and Single-Ended Input Signals

Summing Two Single-Ended Input Signals

Four resistors and three capacitors are needed for summing single-ended input signals. The gain and corner frequencies (f_{c1} and f_{c2}) for each input source can be set independently (see equations (11) through (14), and Figure 28). Resistor, R_P , and capacitor, C_P , are needed on the $IN+$ terminal to match the impedance on the $IN-$ terminal. The single-ended inputs must be driven by low impedance sources even if one of the inputs is not outputting an ac signal.

$$\text{Gain1} = \frac{V_O}{V_{I1}} = \frac{2 \times 150\text{k}\Omega}{R_{I1}} \left(\frac{V}{V} \right) \text{-----(11)}$$

$$\text{Gain2} = \frac{V_O}{V_{I2}} = \frac{2 \times 150\text{k}\Omega}{R_{I2}} \left(\frac{V}{V} \right) \text{-----(12)}$$

$$C_{I1} = \frac{1}{(2\pi R_{I1} f_{c1})} \text{-----(13)}$$

$$C_{I2} = \frac{1}{(2\pi R_{I2} f_{c2})} \text{-----(14)}$$

$$C_P = C_{I1} + C_{I2} \text{-----(15)}$$

$$R_P = \frac{R_{I1} \times R_{I2}}{(R_{I1} + R_{I2})} \text{----- (16)}$$

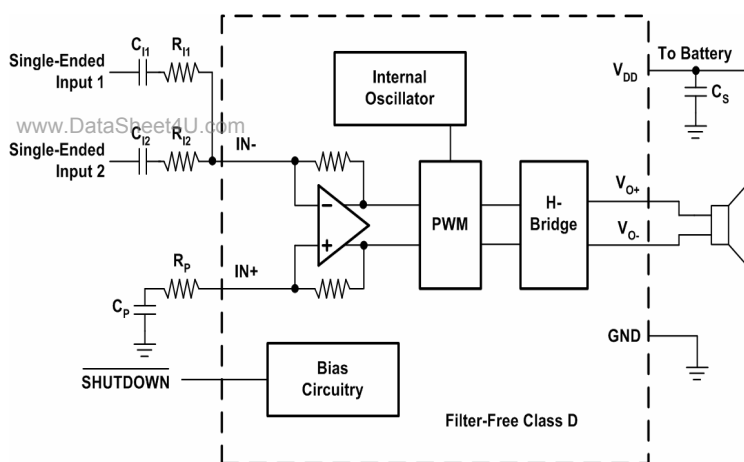

**Figure 28. Application Schematic With EUA2005
Summing Two Single-Ended Input**

Packaging Information

DFN-8

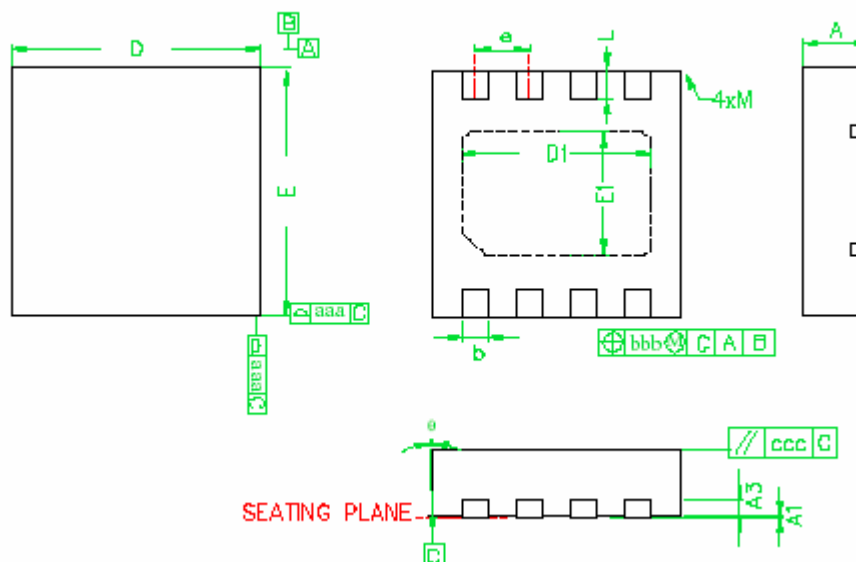

NOTE

1. All dimensions are in millimeters, θ is in degrees
2. M: The maximum allowable corner on the molded plastic body corner
3. Dimension D does not include mold protrusions or gate burrs. Mold protrusions and gate burrs shall not exceed 0.15mm per side
4. Dimension E does not include interterminal mold protrusions or terminal protrusions. Interterminal mold protrusions and/or terminal protrusions shall not exceed 0.20mm per side
5. Dimension b applies to plated terminals. Dimension A1 is primarily Y terminal plating, but may or may not include a small protrusion of terminal below the bottom surface of the package
6. Burr shall not exceed 0.060mm
7. JEDEC MO-229

www.DataSheet4U.com

SYMBOLS	DIMENSIONS IN MILLIMETERS		
	MIN.	NOM.	MAX.
A	0.70	0.80	0.90
A1	0	0.015	0.03
A3	-----	0.20 REF	-----
b	0.20	0.30	0.40
D	2.85	3.00	3.15
D1	-----	2.30 BSC	-----
E	2.85	3.00	3.15
E1	-----	1.50 BSC	-----
e	-----	0.65 BSC	-----
L	0.25	0.35	0.45
aaa	-----	0.25	-----
bbb	-----	0.10	-----
ccc	-----	0.10	-----
M	-----	-----	0.05
θ	-12	-----	0