

1. General Description

KK16C554 is an enhanced quadruple version of the 16C550 UART (Universal Asynchronous Receiver Transmitter). Each channel can be put into FIFO mode to relieve the CPU of excessive software overhead. In this mode, internal FIFOs are activated and 16 bytes plus 3 bit of error data per byte can be stored in both receive and transmit modes.

Each channel performs serial-to-parallel conversion on data characters received from a peripheral device or a MODEM, and parallel-to-serial conversion on data characters received from the CPU. The CPU can read the complete status of the UART at any time during the functional operation. The Status information includes the type and condition of the transfer operations being performed by the UART, as well as any error conditions such as parity, overrun, framing, and break interrupt.

KK16C554 includes a programmable baud rate generator which is capable of dividing the timing reference clock input by divisors of 1 to $2^{16}-1$, and producing a 16x clock for driving the internal transmitter logic. Provisions are also included to use this clock to drive the receiver logic.

KK16C554 has complete MODEM-control capability and an interrupt system that can be programmed to the user's requirements, minimizing the computing required to handle the communication links.

2. Features

- In the FIFO mode, Each channel's transmitter and receiver is buffered with 16-byte FIFO to reduce the number of interrupts to CPU.
- Adds or deletes standard asynchronous communication bits (start, stop, parity) to or from the serial data.
- Holding Register and Shift Register eliminate need for precise synchronization between the CPU and serial data.
- Independently controlled transmit, receive, line status and data interrupts.
- Programmable Baud Rate Generators which allow division of any input reference clock by 1 to $2^{16}-1$ and generate an internal 16X clock.
- Independent receiver clock input
- Modem control functions (CTS#, RTS#, DSR#, DTR#, RI#, and DCD#).
- Fully programmable serial interface characteristics.
 - 5-, 6-, 7-, or 8-bit characters
 - Even-, Odd-, or No-Parity bit
 - 1-, 1.5-, 2-Stop bit generation. (Like other general UARTs, KK16C554 checks only one stop bit, no matter how many they are)
- False start bit detection
- Generates or Detects Line Break
- Internal diagnostic capabilities : Loop-back controls for communications link fault isolation.
- Full prioritized interrupt system controls

3. Signal Description

NAME	PIN NO.	I/O	DESCRIPTION	
A0 A1 A2	34 (48) [†] 33 (47) 32 (46)	I	Register select pins. A0, A1, and A2 three inputs are used to select the register of the UART during read and write operations.	
CS0#, CS1# CS2#, CS3#	16,20 (28, 33) 50,54 (68, 73)	I	Chip Select. Each CSx# enables read and write operations to its respective channel.	
CTS0#, CTS1# CTS2, CTS3#	11,25 (23, 38) 45,59 (63, 78)	I	Clear to send. CTSx# is a modem status signal. Its status can be known by reading bit 4 of the modem status register. CTS# does not affect the transmitter receive operation.	
D7~D3, D2~D0	66~68(15~11) 1~ 5 (9~7)	I/O	Data Bus. Eight data lines with 3-state outputs provide a bidirectional path for data, control, and status information between the KK16C554 and the CPU. D0 is the LSB.	
DCD0#, DCD1# DCD2#, DCD3#	9,27 (19, 42) 43, 61 (59, 2)	I	Data Carrier Detect. A low on DCDx# indicates the carrier has been detected by the modem. Its condition can be known by reading bit 7 of the modem status register.	
DSR0#, DSR1# DSR2#, DSR3#	10,26 (22, 39) 44,60 (62, 79)	I	Data set ready. DSRx# is a modem status signal. The condition of DSRx# can be checked by reading the Bit 5 of the modem status register. DSR# does not affect the transmit or receive operation.	
DTR0#, DTR1# DTR2#, DTR3#	12, 24(24, 37) 46, 58(64,77)	O	Data Terminal Ready. DTRx# is an output that indicates to a modem or data set that the UART is ready to establish communications. Setting the DTR bit of the modem control register activates it. DTRx# is placed in inactive state either as a result of the master reset during loop mode operation or clearing bit 0 of the modem control register.	
GND	6, 23 (16,36) 40, 57 (56,76)		signal and power ground	
INTN#	65 (6)	I	Interrupt normal. INTN# in conjunction with bit 3 of the modem status register and affects operation of the four interrupts (INT0~INT3).	
			INTN#	Operation Of Interrupts
			Low or Float	Interrupts are enabled according to the state of OUT2 (MCR bit 3). When the MCR bit 3 is cleared, the 3-state interrupt output of that UART is in the high Z state. When MCR bit 3 is set, the interrupt output of the UART is enabled.
High	Interrupts are always activated.			
INT0, INT1 INT2, INT3	15,21(27,34) 19,55(67,74)		External interrupt output. When activated, INTx output informs CPU that UART has an interrupt to be serviced.	
IOR#	52 (70)	I	Read strobe. A low level on IOR# transfers the contents of the KK16C554 data bus to the external CPU bus.	

NAME	PIN NO.	I/O	DESCRIPTION
IOW#	18 (31)	I	Write strobe. IOW# allows the CPU to write into the selected address by the address register.
RESET	37 (53)	I	Master reset. When active, RESET clears most UART registers and sets the state of various signals. The transmitter output and the receiver input is disabled during reset time.
RI0#, RI1# RI2#, RI3#	8, 28 (18,43) 42, 62 (58, 3)	I	Ring detect indicator. A low on Rix# indicates the modem has received a ring signal from the telephone line. The condition of this signal can be checked by reading bit 6 of the modem status register.
RTS0#, RTS1# RTS2#, RTS3#	14, 22 (26,35) 48, 56 (66,75)	O	Request to Send. When active, RTSx# informs the modem or data set that the UART is ready to receive data. Writing a 1 in the modem control register sets this bit to a low state. After reset, this terminal is set high. These terminals have no affect on the transmit or receive operation.
RXD0, RXD1 RXD2, RXD3	7, 29 (17, 44) 41, 63 (57, 4)	I	Serial Input. RXDx is a serial data input from a connected communications device. During loopback mode, the RXDx input is disabled from external connection and connected to the TXDx output internally.
RXRDY #	38 (54)	O	Receive ready. RXRDY# goes low when the receive FIFO is full. It can be used as a single transfer or multi transfer.
TXD0, TXD1 TXD2, TXD3	17, 19 (29,32) 51, 53 (69,72)	O	Transmit output. TXDx is a composite serial data output that is connected to a communications device. TXD1, TXD2, TXD3, and TXD4 are set to the high state as a result of reset.
TXRDY #	39 (55)	O	Transmit Ready. TXRDY# goes low when the transmit FIFO is full. It can be used as a single transfer or multi transfer.
VCC	13, 30 (5, 25) 47, 64 (45,65)		Power supply.
XTAL1	35 (50)	I	Crystal input 1 or external clock input. A crystal can be connected to XTAL1 and XTAL2 to utilize the internal oscillator circuit. An external clock can be connected to drive the internal clock circuits.
XTAL2	36 (51)	O	Crystal output 2 or buffered clock output.

† At the PIN NO, the number outside the parenthesis means the pin number of the KK16C554PL, and the number inside the parenthesis means the pin number of the KK16C554TQ.

4. Functional Block Diagram

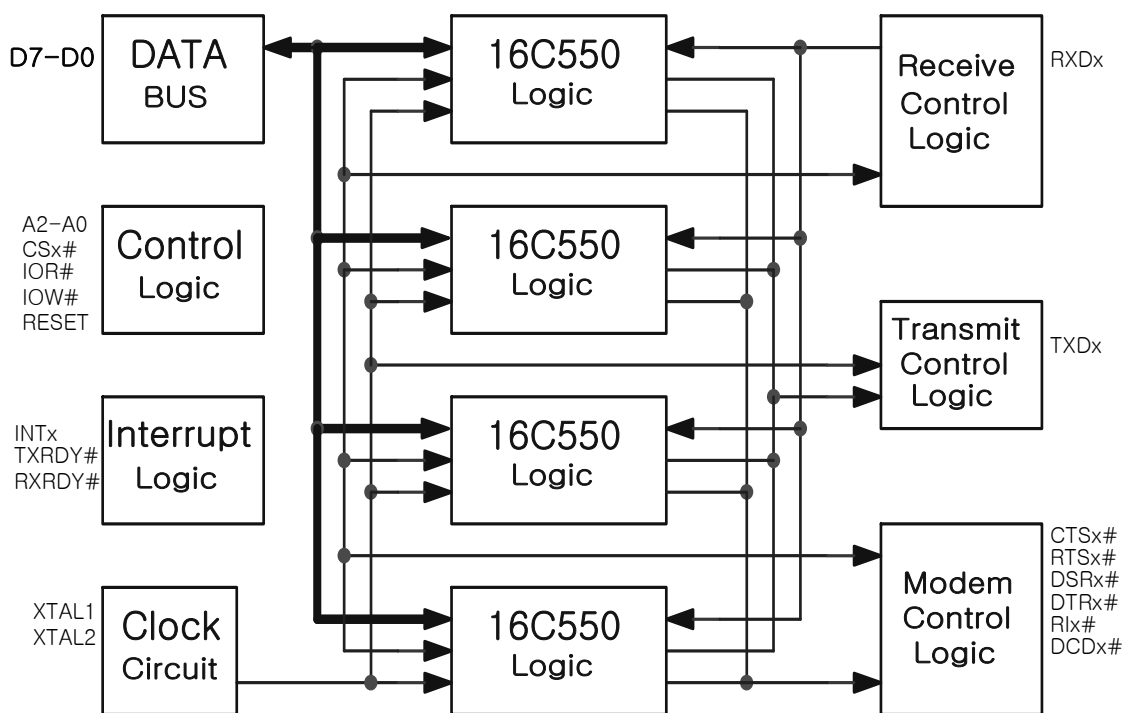

5. Register Description

ADDRESS	REGISTER MNEMONIC	REGISTER ADDRESS							
		BIT 7	BIT 6	BIT 5	BIT 4	BIT 3	BIT 2	BIT 1	BIT 0
0	RBR (read only)	Data bit 7 (MSB)	Data bit 6	Data bit 5	Data bit 4	Data bit 3	Data bit 2	Data bit 1	Data bit 0 (LSB)
0	THR (write only)	Data bit 7	Data bit 6	Data bit 5	Data bit 4	Data bit 3	Data bit 2	Data bit 1	Data bit 0
0 [†]	DLL	Bit 7	Bit 6	Bit 5	Bit 4	Bit 3	Bit 2	Bit 1	Bit 0
1 [†]	DLM	Bit 15	Bit 14	Bit 13	Bit 12	Bit 11	Bit 10	Bit 9	Bit 8
1	IER	0	0	0	0	(EDSSI) Enable modem status interrupt	(ERLSI) Enable receiver line status interrupt	(ETBEI) Enable Transmitter Holding register empty interrupt	(ERBI) Enable received data available interrupt
2	FCR (write only)	Receiver Trigger (MSB)	Receiver Trigger (LSB)	Reserved	Reserved	DMA mode select	Transmit FIFO reset	Receiver FIFO reset	FIFO enable
2	IIR (read only)	FIFOs [‡] Enabled	FIFOs [‡] Enabled	0	0	Interrupt [‡] ID Bit (3)	Interrupt ID Bit (2)	Interrupt ID Bit (1)	0 if interrupt pending
3	LCR	(DLAB) Divisor latch access bit	Set break	Stick Parity	(EPS) Even parity select	(PEN) Parity Enable	(STB) Number of Stop bits	(WLSB1) Word length select bit 1	(WLSB0) Word length select bit 0
4	MCR	0	0	0	Loop	OUT2 Enable external interrupt (INT)	Reserved	(RTS) Request to Send	(DTR) Data terminal ready
5	LSR	Error in receiver FIFO	(TEMT) Transmitter registers empty	(THRE) Transmitter holding register empty	(BI) Break interrupt	(FE) Framing Error	(PE) Parity Error	(OE) Overrun error	(DR) Data ready
6	MSR	(DCD) Data carrier detect	(RI) Ring indicator	(DSR) Data set Ready	(CTS) Clear to Send	(ΔDCD) Delta data carrier detect	(TERI) Trailing Edge ring indicator	(ΔDSR) Delta data set ready	(ACTS) Delta clear to send
7	SCR	Bit 7	Bit 6	Bit 5	Bit 4	Bit 3	Bit 2	Bit 1	Bit 0

[†] DLAB = 1

[‡] This bit is always in a low state when FIFO is disabled.

5.1. FIFO control register(FCR)

The FCR is a write-only register at the same address as the IIR. FCR enables FIFO, sets the trigger level of the receiver FIFO, and selects the type of DMA signaling.

- Bit 0 : FCR0 enables transmit and receiver FIFOs. All bytes in both FIFOs can be cleared by clearing this bit. Data is cleared automatically from the FIFOs when changing from the FIFO mode to the 16C550 mode and vice versa. Programming of other FCR bits is enabled by setting this bit.
- Bit 1 : When set, FCR1 clears all bytes in the receiver FIFO and resets its counter. This does not clear the shift register.
- Bit 2 : When set, FCR2 clears all bytes in the transmitter FIFO and resets its counter. This does not clear the shift register.
- Bit 3 : When set, FCR3 changes RXRDY# and TXRDY# from mode 0 to mode 1 if FCR0 is set.
- Bit 4, 5 : Reserved for the future use.
- Bit 6, 7 : FCR6 and FCR7 set the trigger level for the receiver FIFO interrupt. (see Table 1).

Table 1. Receiver FIFO Trigger Level

BIT		Receiver FIFO Trigger Level
7	6	
0	0	01
0	1	04
1	0	08
1	1	14

* FIFO interrupt mode operation

The following receiver status occurs when the receiver FIFO and receiver interrupts are enabled.

1. LSR0 is set when a character is transferred from the shift register to the receiver FIFO. When the FIFO is empty, it is reset.
2. Receiver line status interrupt(IIR = 06) has higher priority than the receive data available interrupt(IIR = 04).
3. Receive data available interrupt is issued to the CPU when the programmed trigger level is reached by the FIFO. As soon as the FIFO drops below its programmed trigger level, it is cleared.
4. Receive data available indicator(IIR=04) also occurs when the FIFO reaches its trigger level. It is cleared when the FIFO drops below the programmed trigger level.

The following receiver FIFO character time-out status occurs when receiver FIFO and receiver interrupts are enabled.

1. When the following conditions exist, a FIFO character time-out interrupt occurs.
 - a. Minimum of one character in FIFO.
 - b. Last received serial character is longer than four continuous previous character times ago. (If two stop bits are programmed, the second one is included in the time delay. Only the first stop bit is checked by the UART.)
 - c. The last CPU of the FIFO read is more than four continuous character times earlier.
2. By using the XTAL1 input for a clock signal, the character times can be calculated. The delay is proportional to the baud rate.

3. The time-out timer is reset after the CPU reads the receiver FIFO or after a new character is received. This occurs when there has been no time-out interrupt.
4. A time-out interrupt is cleared and the timer is reset when the CPU reads a character from the receiver FIFO.

Transmit interrupts occurs as follows when the transmitter and transmit FIFO interrupts are enabled (FCR=0, IER=1).

1. When the transmitter FIFO is empty, the transmitter holding register interrupt (IIR=02) occurs. The interrupt is cleared when the transmitter holding register is written to or the IIR is read. 1 to 16 characters can be written to the transmit FIFO when servicing this interrupt.
2. The transmitter FIFO empty indicators are delayed one character time minus the last stop bit time whenever the following occurs.

THRE=1, and there has not been a minimum of two bytes at the same time in transmit FIFO since the last THRE=1. The first transmitter interrupt after changing FCR0 is immediate, however, assuming it is enabled.

Receiver FIFO trigger level and character time-out interrupts have the same priority as the receive data available interrupt.

The transmitter holding register empty interrupt has the same priority as the transmitter FIFO empty interrupt.

5.2. Line Control Register

The format of the data character is controlled by the LCR.

- Bit 0, 1 : LCR0 and LCR1 are word length select bits. (see Figure 1)
- Bit 2 : LCR2 is the stop bit select bit. The receiver always checks for one stop bit.
- Bit 3 : LCR3 is the parity enable bit. When LCR3 is set, a parity bit is generated and checked.
- Bit 4 : LCR4 is the even parity select bit. When LCR3 and this bit is set, even parity is generated and checked. When LCR3 is set and this bit is cleared, odd parity is selected.
- Bit 5 : LCR5 is the stick parity select bit. When LCR3 and this bit is set, the transmission and the reception of a parity bit is forced to an opposite state from the value of LCR4. Clearing this bit disables the stick parity.
- Bit 6 : LCR6 is a break control bit. When this bit is set, the serial outputs TXDXs are forced to '0'. The break control bit acts only on the serial output and does not affect the transmitter logic. If the following sequence is used, no invalid characters are transmitted because of the break.
 1. Load a zero byte in response to the transmitter holding register empty(THRE) status indicator.
 2. The next THRE signal in the response of the set the break.
 3. Wait for the transmitter to be idle, when transmitter empty status signal is set (TEMT=1) and then clear the break, and start the normal transmission.
- Bit 7 : LCR7 is the divisor latch access bit(DLAB). This bit must be set to access the divisor latches DLL and DLM of the baud rate generator during a read or write operation. LCR7 must be cleared to access the Receiver Buffer Register, the Transmitter Holding Register, or the Interrupt Enable Register.

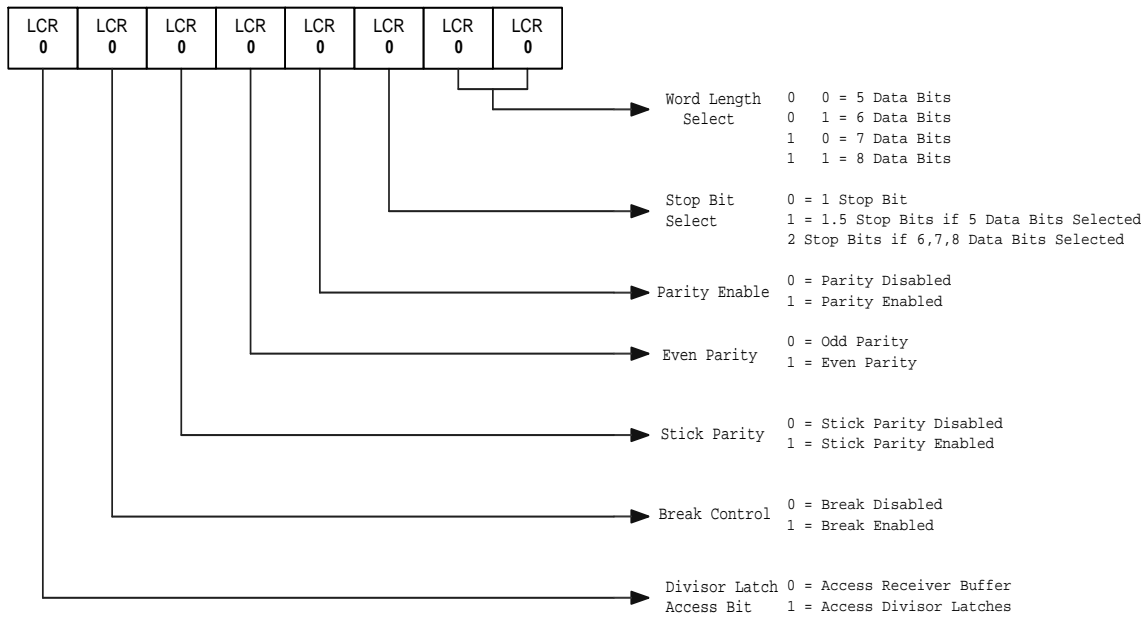

Figure 1. Line Control Register

*** Programmable Baud Generator**

The UART contains a programmable Baud Generator that is capable of taking any clock input from DC to 14.7456MHz and dividing it by any divisor from 2 to $2^{16}-1$. 4MHz is the highest clock input recommended when the divisor = 1. The output frequency of the baud generator is 16 x baud [divisor # = (frequency input)/(baud rate X 16)]. Two 8-bit latches store the divisor in a 16-bit binary format. These Divisor Latches must be loaded during initialization to ensure proper operation of the Baud Generator. (see Table 2.)

Table 2. Baud rates

This table provides decimal divisors to use with crystal frequencies of 1.8432MHz, 3.6864MHz, 7.3728MHz and 14.7456MHz. For baud rates of 38400 and below, the error obtained is minimal. The accuracy of the desired baud rate is dependent on the frequency of the crystal. It is not recommended using a divisor of zero.

Desired baud rate	Decimal divisor to generate 16x Clock			
	1.8432MHz	3.6864MHz	7.3728MHz	14.7456MHz
50	2304	4608	9216	18432
75	1536	3072	6144	12288
134.5	857	1714	3428	6856
150	768	1536	3072	6144
300	384	768	1536	3072
600	192	384	768	1536
1200	96	192	384	768
1800	64	128	256	512
2000	58	116	232	464
2400	48	96	192	384
3600	32	64	128	256
4800	24	48	96	192
7200	16	32	64	128
9600	12	24	48	96
19.2K	6	12	24	48
38.4K	3	6	12	24
57.6K	2	4	8	16
115.2K	1	2	4	8
230.4K	-	1	2	4
460.8K	-	-	1	2
921.6K	-	-	-	1

5.3. Line Status Register

This register provides status information to the CPU concerning the data transfer.

- Bit 0 : Data Ready(DR) indicator. Bit 0 is set to a logic 1 whenever a complete incoming character has been received and transferred into the Receiver Buffer Register or the FIFO. This bit is cleared by reading all of the data in the Receiver Buffer Register of the FIFO.
- Bit 1 : Overrun Error(OE) indicator. Bit 1 indicates that data in the Receiver Buffer Register was not read by the CPU before the next character was transferred into the Receiver Buffer Register, thereby destroying the previous character. This bit is set to a logic 1 when overrun occurs and cleared whenever the CPU reads the contents of the Line Status Register. If the FIFO mode data continues to fill the FIFO beyond the trigger level, an overrun error will occur only after the FIFO is full and the next character has been completely received in the shift register. OE is indicated to the CPU as soon as it happens. The character in the shift register is overwritten, but it is not transferred to the FIFO.
- Bit 2 : Parity Error indicator. Bit 2 is set to a logic 1 upon detection of a parity error and is reset to a logic 0 whenever CPU reads the contents of the Line Status Register. In the FIFO mode, this error is revealed to CPU when its associated character is at the top of the FIFO.
- Bit 3 : Framing Error indicator. Bit 3 indicates that the received character did not have a valid stop bit. This bit is set to a logic 1 whenever the stop bit following the last data bit or parity bit is detected as a logic 0 bit. It is reset to a logic 0 whenever CPU reads the contents of the Line Status Register. In the FIFO mode, this error is revealed to CPU when its associated character is at the top of the FIFO. When this error has been detected, CPU assumes it due to a next start bit, so it samples this start bit twice and the take the data.
- Bit 4 : Break Interrupt indicator. Bit 4 is set to a logic 1 when the received data input is held in the spacing state for longer than a full word transmission time (start bit + data bits + parity bit + stop bits). The BI indicator is reset to a logic 0 whenever the CPU reads the contents of the Line Status Register. In the FIFO mode, this error is revealed to CPU when its associated character is at the top of the FIFO. When break occurs, only one zero character is loaded into the FIFO. The next character transfer is enabled after SIN goes HIGH and receives the next start bit.
- Bit 5 : Transmitter holding register empty(THRE) indicator. Bit 5 indicates that the UART is ready to take a new character for transmission. In addition, this bit causes the UART to issue an interrupt to the CPU when the Transmit Holding Register Empty interrupt enable is set to HIGH. This bit is set to a logic 1 when a character is transferred from the Transmitter Holding Register into the Transmitter shift register. And it is reset to a logic 0 when the CPU transfers data to the Transmitter Holding Register. In the FIFO mode, this bit is set to a logic 1 when the XMIT FIFO is empty, and is reset to a logic 0 when at least one byte is written to the XMIT FIFO.
- Bit 6 : Transmitter Empty indicator. This bit is set when the Transmitter Holding Register and Transmitter Shift Register are both empty, and reset to a logic 0 when the THR contains a data character. In the FIFO mode, it is set to a logic 1 when the both the Transmitter FIFO and the Transmitter Shift Register are empty.
- Bit 7 : In the 16C550 mode, this bit is a 0. In the FIFO mode it is set to a logic 1 when it contains at least one error such as parity error, framing error or break error. This bit is reset to a logic 0 when the CPU reads the Line Status Register and there exists no error.

5.4. Interrupt Identification Register

In order to provide minimum software overhead during data transfer, the UART prioritizes interrupts into 4 levels and record these in the Interrupt Identification Register. The four levels of interrupt conditions are, in order of priority:

- Receiver Line Status
- Received Data Ready
- Transmitter Holding Register Empty
- MODEM Status

When the CPU accesses the IIR, the UART freezes all interrupts and indicates the highest priority pending interrupt to the CPU. While this CPU access is occurring, the UART records new interrupts, but does not change its current indication until the access is complete.

Bit 0 : This bit can be used in a prioritized interrupt environment to indicate whether an interrupt is pending. When bit 0 is a logic 0, an interrupt is pending and the IIR contents may be used as a pointer to the appropriate interrupt service routine. When bit 0 is a logic 1, no interrupt is pending.

Bit 1, 2 : These two bits of the IIR are used to identify the highest priority interrupt pending as indicated in Table 3.

Bit 3 : In the 16C550 mode, this bit is 0. In the FIFO mode, this bit is set along with bit 2 when a time-out interrupt is pending.

Bit 4, 5 : These two bits are always logic 0.

Bit 6, 7 : These two bits are set whenever FCR0 is a logic 1.

Table 3. Interrupt Control Function

FIFO mode only	Interrupt Identification Register			Interrupt set / reset Function				
	Bit 3	Bit 2	Bit 1	Bit 0	Priority Level	Interrupt Type	Interrupt Source	Interrupt Reset Control
	0	0	0	1	-	-	-	-
	0	1	1	0	1	Receiver Line Status	OE, PE, FE, BI	Reading the LSR
	0	1	0	0	2	Receiver Data Available	Receiver Data Available or Trigger level reached	Reading the RBR or the FIFO drops below the trigger level
	1	1	0	0	2	Character Timeout Indication	No character has been removed since the last transfer and there was no transfer at the FIFO during the 4 character time.	Reading the RBR
	0	0	1	0	3	Transmitter Holding Register Empty	Transmitter Holding Register Empty	Reading the IIR (if source of the interrupt) or writing the THR
	0	0	0	0	4	Modem Status	CTS, DSR, RI, DCD	Reading the MSR

5.5. Interrupt Enable Register

The IER independently enables the four serial channel interrupt sources that activate the interrupt(INT0, INT1, INT2, INT3) output. All interrupts are disabled by clearing IER0-IER3 of the IER. Interrupts are enabled by setting the appropriate bits of the IER. Disabling the interrupt system inhibits the IIR and the active high interrupt output. All other system functions operate in their normal manner, including the setting of the LSR and MSR. The contents of the IER are described in the following bulleted list.

- Bit 0 : When IER0 is set, IER0 enables the received data available interrupt and the timeout interrupts in the FIFO mode.
- Bit 1 : When IER1 is set, the transmitter holding register empty interrupt is enabled.
- Bit 2 : When IER2 is set, the receiver line status interrupt is enabled.
- Bit 3 : When IER3 is set, the modem status interrupt is enabled.
- Bit 4~7 : These bits are cleared.

5.6. Modem Control Register

The MCR controls the interface with the modem or data set as described in Figure 2. MCR can be written and read. The RTS# and DTR# outputs are directly controlled by their control bits in this register. A high input asserts a low signal at the output terminals. MCR bits 0-4 are shown as follows.

- Bit 0 : When MCR0 is set, the DTR# output is forced low. When MCR0 is cleared, the DTR# output is forced high. The DTR# output of the serial channel may be input into an inverting line driver in order to obtain the proper polarity input at the modem or data set.
- Bit 1 : When MCR1 is set, the RTS# output is forced to 0. When MCR1 is cleared, the RTS# output is forced high. The DTR# output of the serial channel may be input into an inverting line driver in order to obtain the proper polarity input at the modem or data set.
- Bit 2 : MCR2 has no affect on operation.
- Bit 3 : When MCR3 is set, the external serial channel interrupt is enabled.
- Bit 4 : MCR4 provides a local loopback feature for diagnostic testing of the channel. When MCR4 is set, serial output TXDx is set to the high state and SIN is disconnected. The output of the TSR is looped back into the RSR input. The four modem control inputs (CTS#, DSR#, DCD#, RI#) are disconnected. The modem control outputs (DTR#, RTS#) are internally connected to the four modem control inputs. The modem control output terminals are forced to their inactive state on the KK16C554. In the diagnostic mode, data transmitted is immediately received. This allows the processor to verify the transmit and receive data path of the selected serial channel. Interrupt control is fully operational; however, interrupts are generated by controlling the lower four MCR bits internally. Interrupts are not generated by activity on the external terminals represented by those four bits.
- Bit 5~7 : These bits are permanently cleared.

5.7. Modem Status Register

The MSR provides the CPU with status of the modem input lines for the modem or peripheral devices. The MSR allows the CPU to read the serial channel modem signal inputs by accessing the data bus interface of the UART. It also reads the current status of four bits of the MSR that indicate whether the modem inputs have changed since the last reading of the MSR. The delta status bits are set when a control input from the modem changes states and are cleared when the CPU reads the MSR. The contents of the MSR are shown as follows.

- Bit 0 : Delta Clear to Send(DCTS) indicator. DCTS indicates that the CTS# input to the serial channel has changed state since it was last read by the CPU.
- Bit 1 : Delta Data Set Ready(DDSR) indicator. DDSR indicates that the DSR# input to the serial channel has changed state since it was last read by the CPU.
- Bit 2 : Trailing Edge of Ring Indicator(TERI) indicator. TERI indicates that the RI# input to the serial channel has changed states from low to high since the last time it was read by the CPU. High to low transitions on RI do not activate TERI.
- Bit 3 : Delta Data Carrier Detect(DDCD) indicator. DDCD indicates that the DCD# input to the serial channel has changed state since it was last read by the CPU.
*** note : An interrupt is generated whenever the bit0~3 of the MSR is set to a logic 1.**
- Bit 4 : Clear to Send bit. CTS is the complement of the CTS# input from the modem indicating to the serial channel that the modem is ready to provide received data from the serial channel receiver circuitry. When the channel is in the loop mode, MSR4 reflects the value of RTS in the MCR.
- Bit 5 : Data Set Ready bit. DSR is the complement of the DSR# input from the modem to the serial channel that indicates that the modem is ready to provide received data from the serial channel receiver circuitry. When the channel is in the loop mode, MSR5 reflects the value of DTR in the MCR.
- Bit 6 : Ring indicator bit. RI is the complement of the Rix# inputs. When the channel is in the loop mode, MSR6 reflects the value of OUT1# in the MCR.
- Bit 7 : Data Carrier Detect bit. Data carrier detect indicates the status of the data carrier detect input. When the channel is In the loop mode, MSR7 reflects the value of OUT2# in the MCR.

5.8. Scratch Register

This 8-bit read/write register has no affect on either channel of the UART. It is intended to be used by the programmer to hold data temporarily.

6. Package Diagram

C

PL PACKAGE (Top)

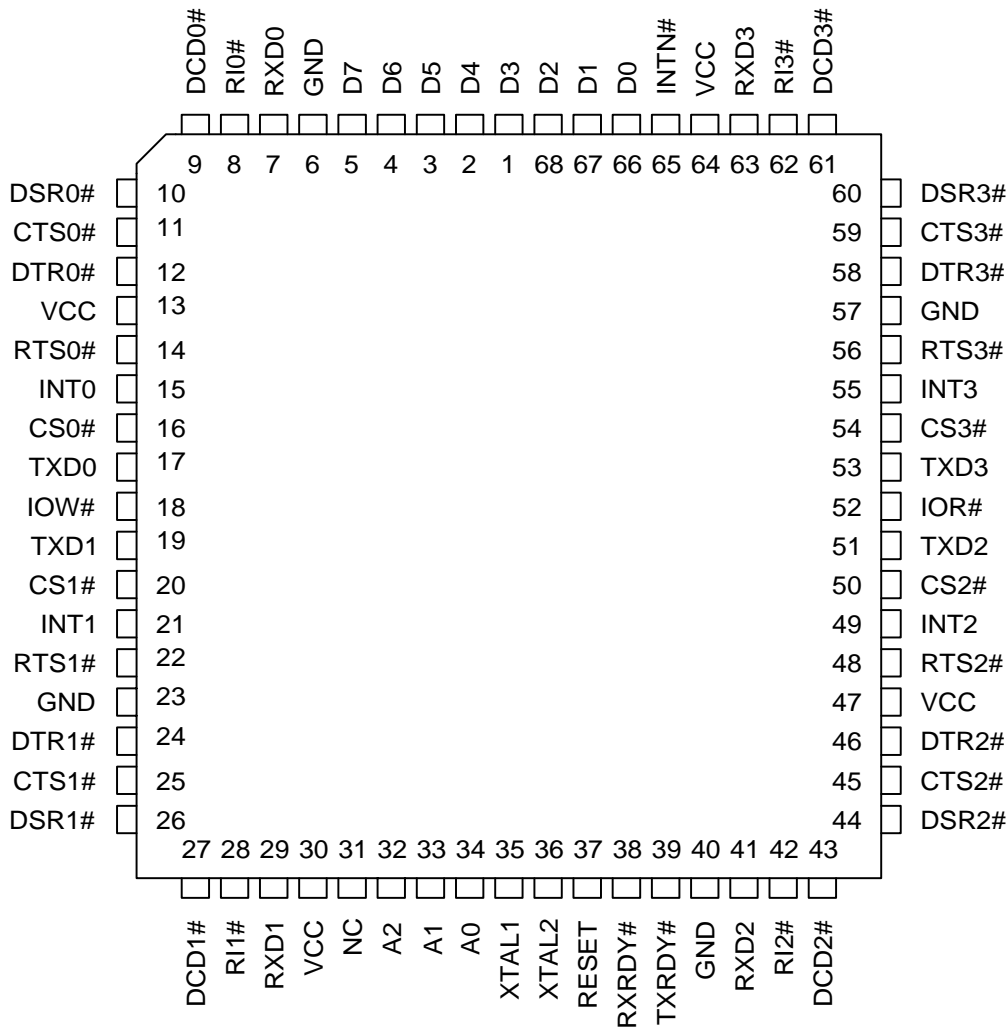

NC - No internal connection

KK16C554TQ PACKAGE (Top)

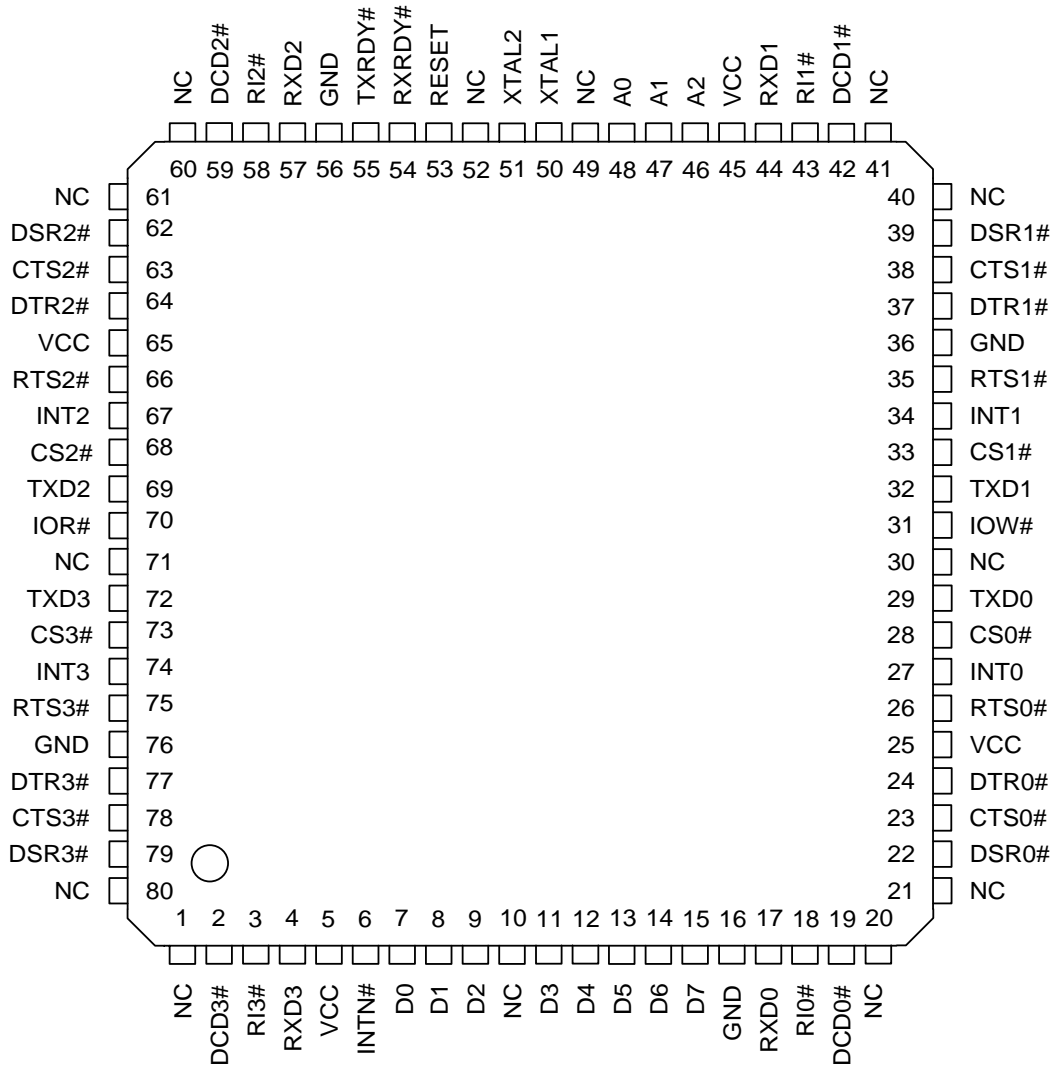

NC - No internal connection

7. Operating Conditions

7.1. General Operating Conditions

	MIN	NOM	MAX	UNIT
Supply Voltage, Vcc	4.75	5	5.25	V
Clock high-level input voltage at XTAL1, V _{IH(CLK)}	2		Vcc	V
Clock low-level input voltage at XTAL1, V _{IL(CLK)}	-0.5		0.8	V
High-level input voltage, V _{IH}	2.0		Vcc+0.5	V
Low-level input Voltage, V _{IL}	-0.5		0.8	V
Clock frequency, f _{CLOCK}			16	MHz
Operating free-air temperature, T _A	-40		80	°C

7.2. Read cycle timing requirements over recommended ranges of operating free-air temperature and supply voltage (See Fig 1.)

	MIN	MAX	UNIT
t _{rd}	Pulse duration, IOR# low	75	ns
t _{csr}	Set up time, CSx# valid before IOR# low †	10	ns
t _{ar}	Set up time, A2~A0 valid before IOR# low †	15	ns
t _{ra}	Hold time, A2~A0 valid after IOR# high †	0	ns
t _{rcs}	Hold time, CSx# valid after IOR# high †	0	ns
t _{ffc}	Delay time, t _{ar} +t _{rd} +t _{rc} ‡	140	ns
t _{rc}	Delay time, IOR# high to IOR# or IOW# low	50	ns

† The internal address strobe is always in active state.

‡ In the FIFO mode, t_{d1}=425ns (min) between reads of the FIFO and the status register.

7.3. Write cycle timing requirements over recommended ranges of operating free-air temperature and supply voltage (See Fig 2.)

	MIN	MAX	UNIT
t _{wr}	Pulse duration, IOW#↓	50	ns
t _{csw}	Setup time, CSx# valid before IOW#↓	10	ns
t _{aw}	Setup time, A2~A0 valid before IOW#↓	15	ns
t _{ds}	Setup time, D7~D0 valid before IOW#↑	10	ns
t _{wa}	Hold time, A2~A0 valid after IOW#↑	5	ns
t _{wcs}	Hold time, CSx# valid after IOW#↑	5	ns
t _{dth}	Hold time, D7~D0 valid after IOW#↑	25	ns
t _{fwc}	Delay time, t _{aw} +t _{wr} +t _{wc}	120	ns
t _{wc}	Delay time, IOW#↑ to IOW# or IOR#↓	55	ns

7.4. Read cycle switching characteristics over recommended ranges of operating free-air temperature and supply voltage (See Fig 1.)

	MIN	MAX	UNIT	
t _{rvd}	Enable time, IOR#↓ to D7~D0 valid	30	ns	
t _{hz}	Disable time, IOR# to D7~D0 released	0	20	ns

7.5. Transmitter switching characteristics over recommended ranges of operating free-air temperature and supply voltage (See Fig 3~5.)

		MIN	MAX	UNIT
t_{irs}	Delay time, INTx \downarrow to TXDx \downarrow at start	8	24	RCLK cycles
t_{sti}	Delay time, TXDx \downarrow at start to INTx \uparrow	8	8	RCLK cycles
t_{si}	Delay time, IOW# high or low (WR THR) to INTx \uparrow	16	32	RCLK cycles
t_{sxa}	Delay time, TXDx \downarrow at start to TXRDY# \downarrow		8	RCLK cycles
t_{hr}	Propagation delay time, IOW#(WR THR) \downarrow to INTx \downarrow		35	ns
t_{ir}	Propagation delay time, IOR#(RD IIR) \uparrow to INTx \downarrow		30	ns
t_{wxi}	Propagation delay time, IOW#(WR THR) \uparrow to TXRDY# \uparrow		50	ns

7.6. Receiver switching characteristics over recommended ranges of operating free-air temperature and supply voltage (Fig 6~9.)

		MIN	MAX	UNIT
t_{sint}	Delay time, stop bit to INTx \uparrow or stop bit to RXRDY# or read RBR to set interrupt		1	RCLK cycle
t_{rint}	Propagation delay time, Read RBR/LSR to INTx \downarrow /LSR interrupt \downarrow		40	ns
t_{rint}	Propagation delay time, IOR# RCLK \downarrow to RXRDY# \uparrow		40	ns

7.7. Modem control switching characteristics over recommended ranges of operating free-air temperature and supply voltage (See Fig 10.)

		MIN	MAX	단위
t_{mdo}	Propagation delay time, IOW#(WR MCR) \uparrow to RTSx#, DTRx# \uparrow		50	ns
t_{sim}	Propagation delay time, modem input CTSx#, DSRx#, and DCDx# \downarrow to INTx \uparrow		30	ns
t_{rim}	Propagation delay time, IOR#(RD MSR) \uparrow to interrupt \downarrow		35	ns
t_{sim}	Propagation delay time, Rix# \uparrow to INTx# \downarrow		30	ns

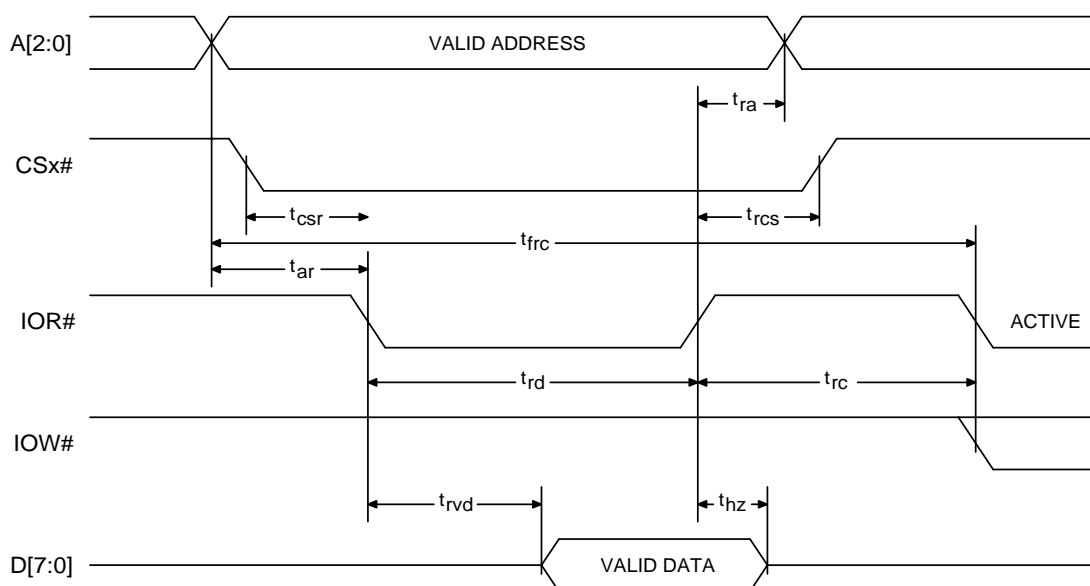

Fig 1. Read Cycle Timing

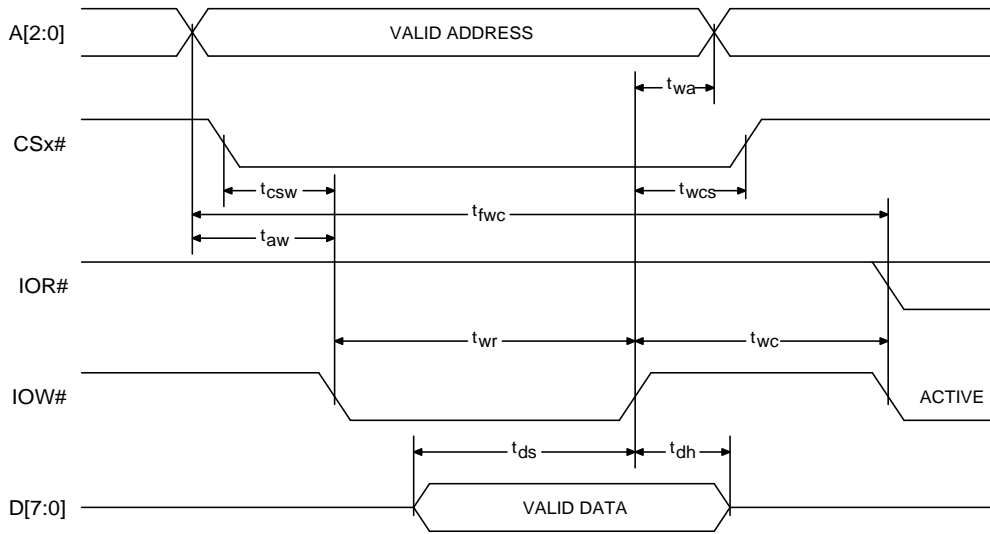

Fig 2. Write Cycle Timing Waveforms

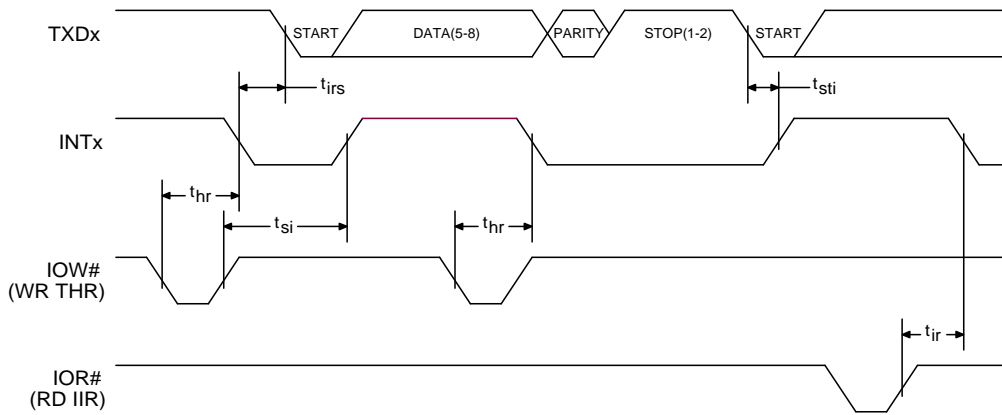

Fig 3. Transmitter Timing Waveforms

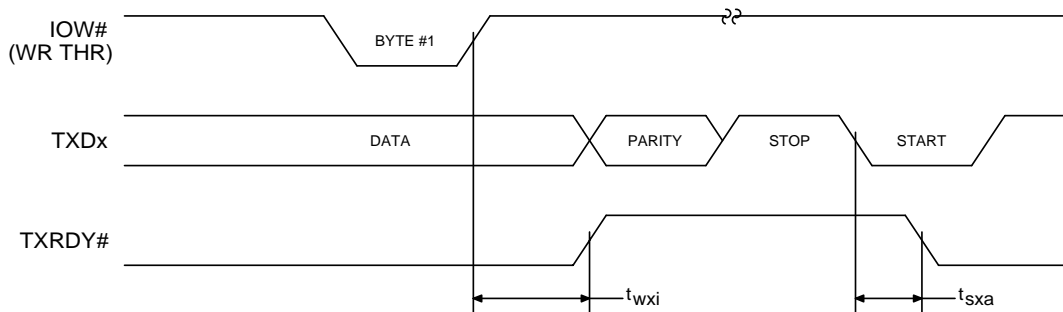

Fig 4. Transmitter Ready Mode 0 Timing Waveforms

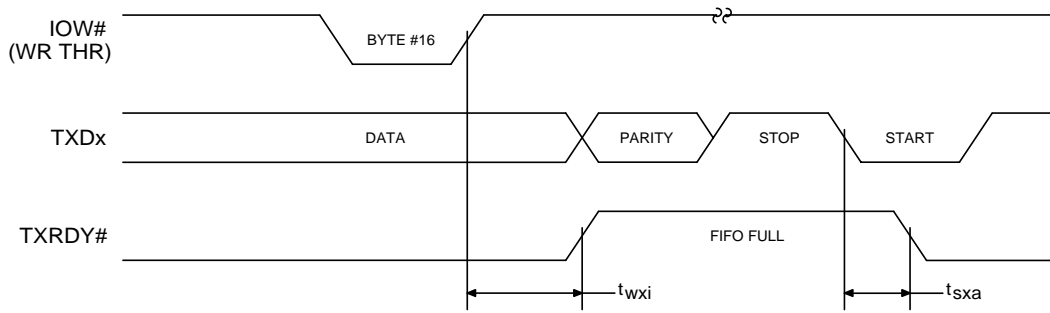

Fig 5. Transmitter Ready Mode 1 Timing Waveforms

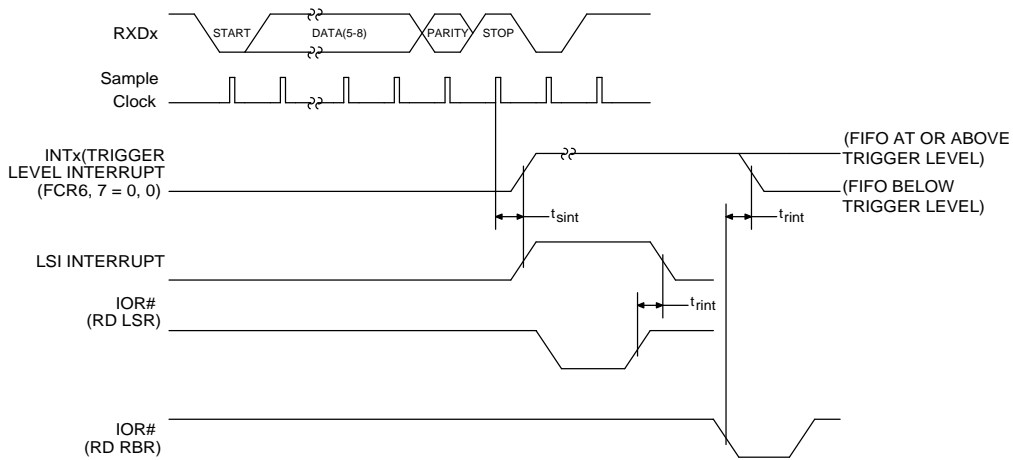

Fig 6. Receiver FIFO First Byte (Sets RDR) Waveforms

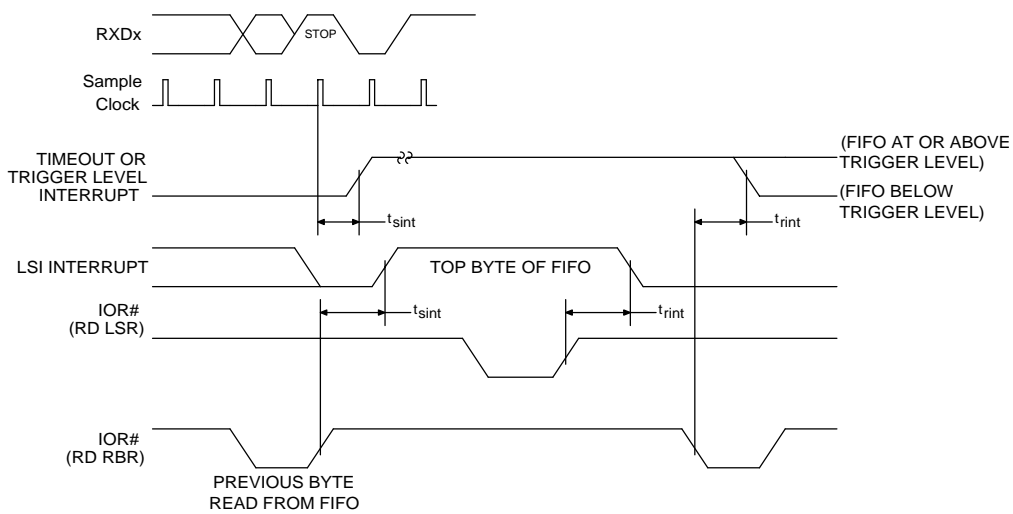

Fig 7. Receiver FIFO After First Byte (After RDR Set) Waveforms

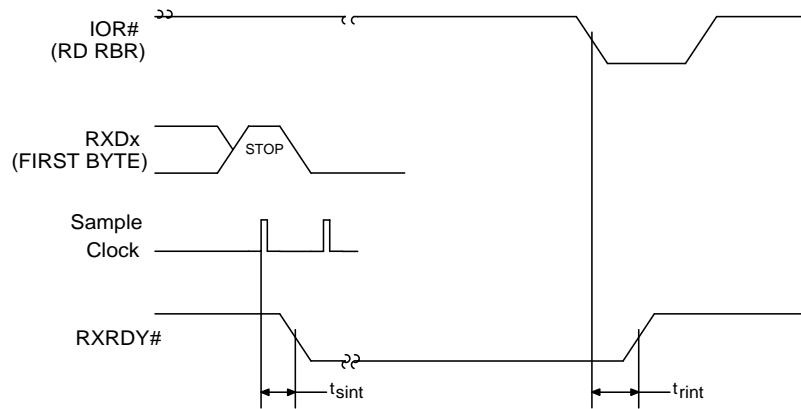

Fig 8. Receiver Ready Mode 0 Timing Waveforms

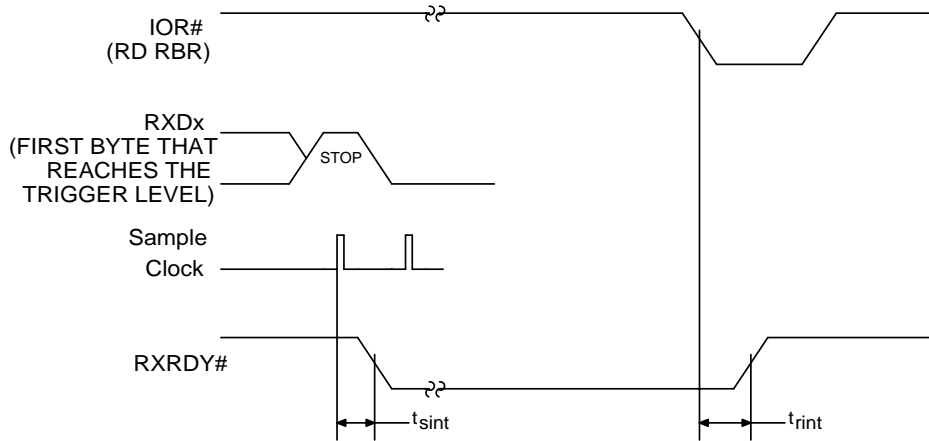

Fig 9. Receiver Ready Mode 1 Timing Waveforms

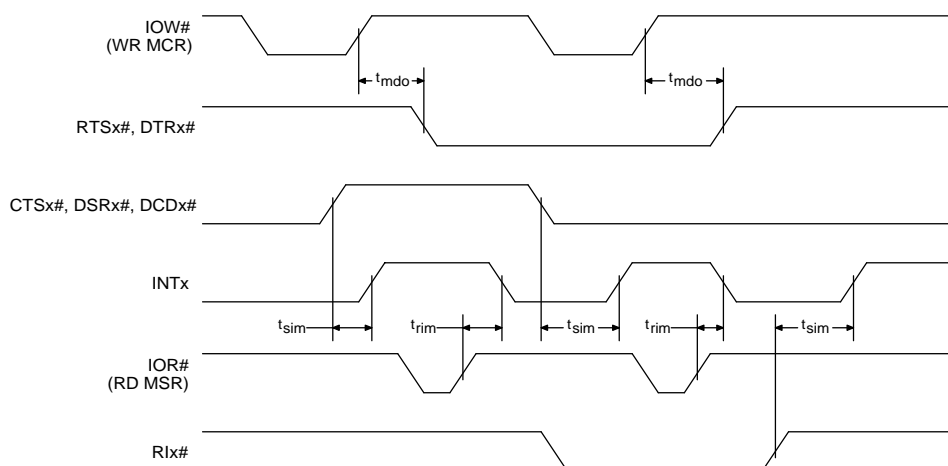
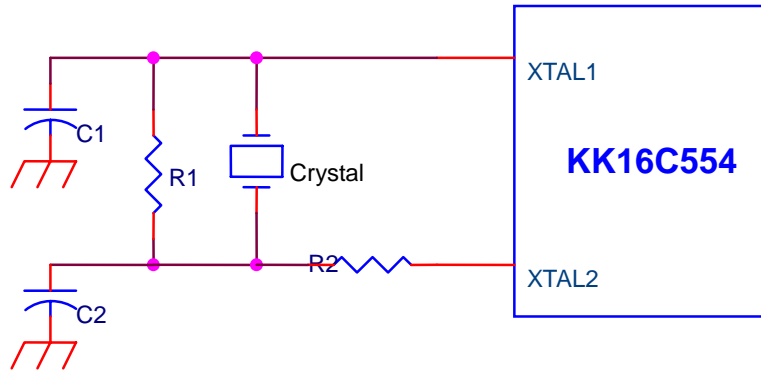

Fig 10. Modem Control Timing Waveforms

*** Typical Clock Circuits**



C1 : 10~30pF, C2 : 40~60pF, R1 : 1MΩ, R2 : 1.5KΩ

8. Mechanical Data

PLCC(Plastic Leaded Chip Carrier) Package

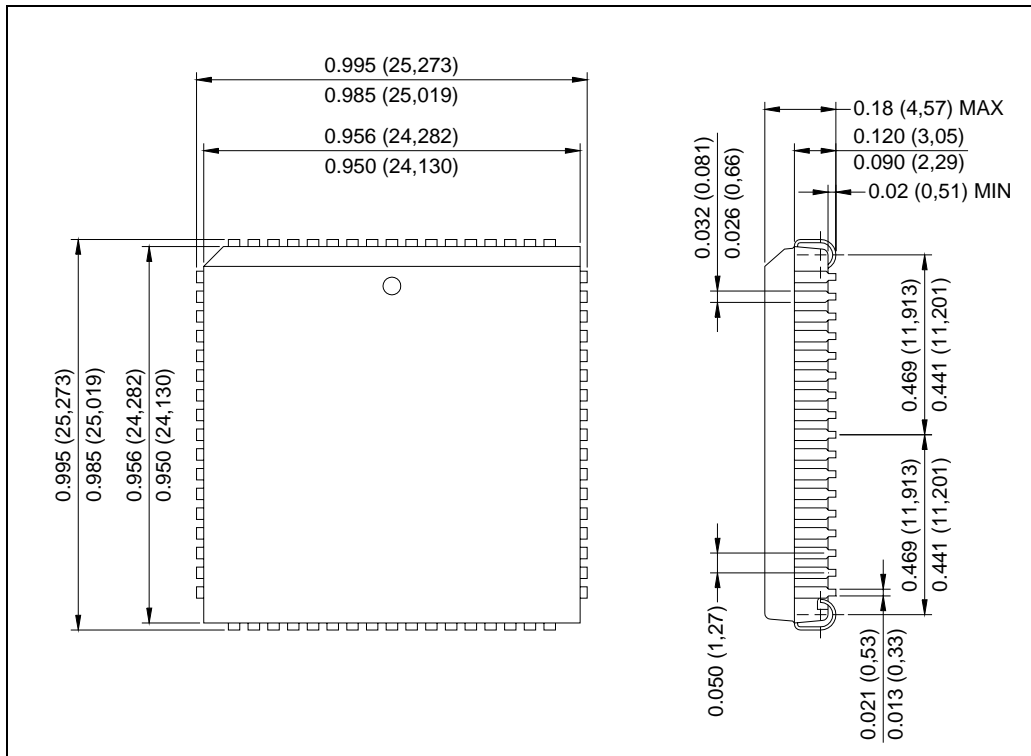

Note

1. All dimensions are in inches (millimeters).
2. Falls within ANSI Y14.5-1982

TQFP(Thin Quad Flat Pack) Package

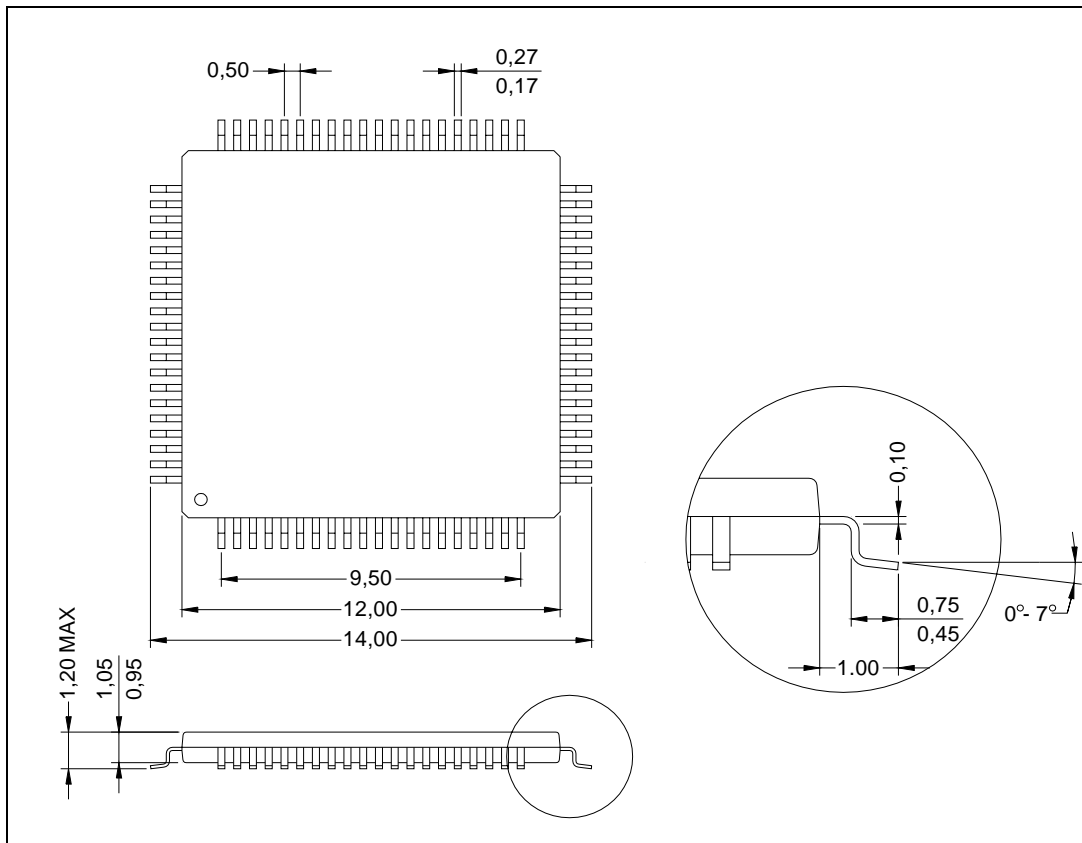

Note

- 1. All dimensions are in millimeters.
- 2. Falls within ANSI Y14.5-1982.