

Features

- High Performance, Low Power AVR[®] 8-Bit Microcontroller
- Advanced RISC Architecture
 - 135 Powerful Instructions – Most Single Clock Cycle Execution
 - 32x8 General Purpose Working Registers
 - Fully Static Operation
 - Up to 16 MIPS Throughput at 16 MHz and 1.8V
 - On-Chip 2-cycle Multiplier
- Non-volatile Program and Data Memories
 - 128K Bytes of In-System Self-Programmable Flash
 - Endurance: 2000 Write/Erase Cycles @ 85°C
 - 4K Bytes EEPROM
 - Endurance: 2000 Write/Erase Cycles @ 85°C
 - 16K Bytes Internal SRAM
- JTAG (IEEE std. 1149.1 compliant) Interface
 - Boundary-scan Capabilities According to the JTAG Standard
 - Extensive On-chip Debug Support
 - Programming of Flash EEPROM, Fuses and Lock Bits through the JTAG interface
- Peripheral Features
 - Multiple Timer/Counter & PWM channels
 - Real Time Counter with Separate Oscillator
 - 10-bit, 330 ks/s A/D Converter; Analog Comparator; On-chip Temperature Sensor
 - Master/Slave SPI Serial Interface
 - Two Programmable Serial USART
 - Byte Oriented 2-wire Serial Interface
- Advanced Interrupt Handler
- Watchdog Timer with Separate On-Chip Oscillator
- Power-on Reset and Low Current Brown-Out Detector
- Advanced Power Save Modes
- Fully integrated Low Power Transceiver for 2.4 GHz ISM Band
 - Supported Data Rates: 250 kb/s and 500 kb/s, 1 Mb/s, 2 Mb/s
 - -100 dBm RX Sensitivity; TX Output Power up to 3.5 dBm
 - Hardware Assisted MAC (Auto-Acknowledge, Auto-Retry)
 - 32 Bit IEEE 802.15.4 Symbol Counter
 - Baseband Signal Processing
 - SFR-Detection, Spreading; De-Spreading; Framing ; CRC-16 Computation
 - Antenna Diversity and TX/RX control
 - TX/RX 128 Byte Frame Buffer
- Hardware Security (AES, True Random Generator)
- Integrated Crystal Oscillators (32.768 kHz & 16 MHz)
- I/O and Package
 - 38 Programmable I/O Lines
 - 64-pad QFN (RoHS/Fully Green)
- Temperature Range: -40°C to 85°C Industrial
- Supply voltage range 1.8V to 3.6V with integrated voltage regulators
- Ultra Low Power consumption (1.8 to 3.6V) for Rx/Tx & AVR: <18.6 mA
 - CPU Active Mode (16MHz): 4.1 mA
 - 2.4GHz Transceiver: RX_ON 12.5 mA / TX 14.5 mA (maximum TX output power)
 - Deep Sleep Mode: <250nA @ 25°C
- Speed Grade: 0 – 16 MHz @ 1.8 – 3.6V

Applications

- ZigBee[®] / IEEE 802.15.4-2006/2003[™] – Full And Reduced Function Device (FFD/RFD)
- General Purpose 2.4GHz ISM Band Transceiver with Microcontroller
- RF4CE, SP100, WirelessHART[™], ISM Applications and IPv6 / 6LoWPAN



**8-bit AVR[®]
Microcontroller
with Low Power
2.4GHz
Transceiver for
ZigBee and
IEEE 802.15.4**

ATmega128RFA1

PRELIMINARY

8266AS-MCU Wireless-12/09





1 Pin Configurations

Figure 1-1. Pinout ATmega128RFA1

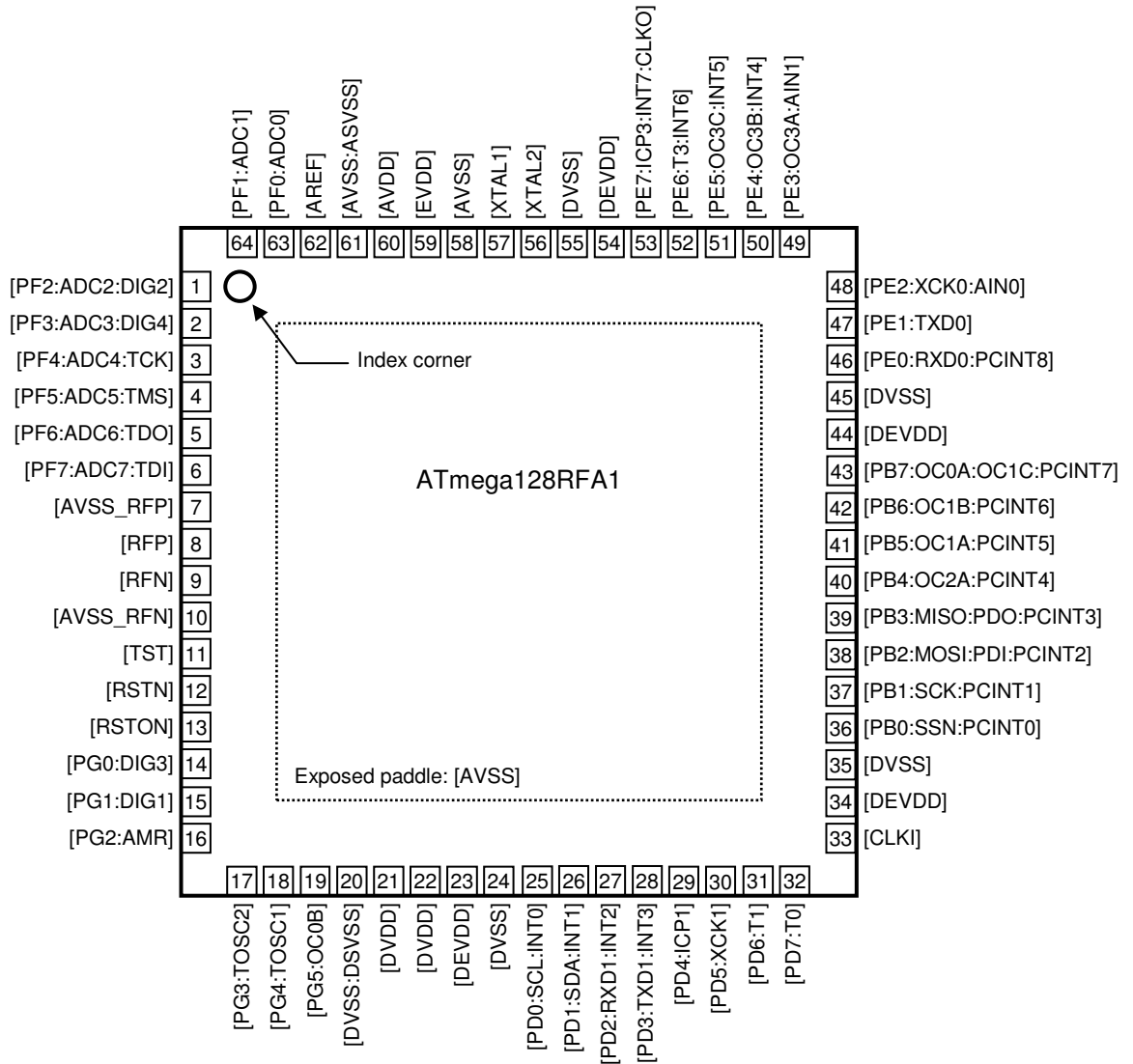

www.DataSheet4U.com

Note: The large center pad underneath the QFN/MLF package is made of metal and internally connected to AVSS. It should be soldered or glued to the board to ensure good mechanical stability. If the center pad is left unconnected, the package might loosen from the board

2 Disclaimer

Typical values contained in this datasheet are based on simulation and characterization results of other AVR microcontrollers and radio transceivers manufactured in a similar process technology. Minimum and Maximum values will be available after the device is characterized.

ATmega128RFA1

3 Overview

The ATmega128RFA1 is a low-power CMOS 8 bit microcontroller based on the AVR enhanced RISC architecture combined with a high data rate transceiver for the 2.4 GHz ISM band. It is derived from the ATmega1281 microcontroller and the AT86RF231 radio transceiver.

By executing powerful instructions in a single clock cycle, the device achieves throughputs approaching 1 MIPS per MHz allowing the system designer to optimize power consumption versus processing speed.

The radio transceiver provides high data rates from 250 kb/s up to 2 Mb/s, frame handling, outstanding receiver sensitivity and high transmit output power enabling a very robust wireless communication.

3.1 Block Diagram

Figure 3-1 Block Diagram

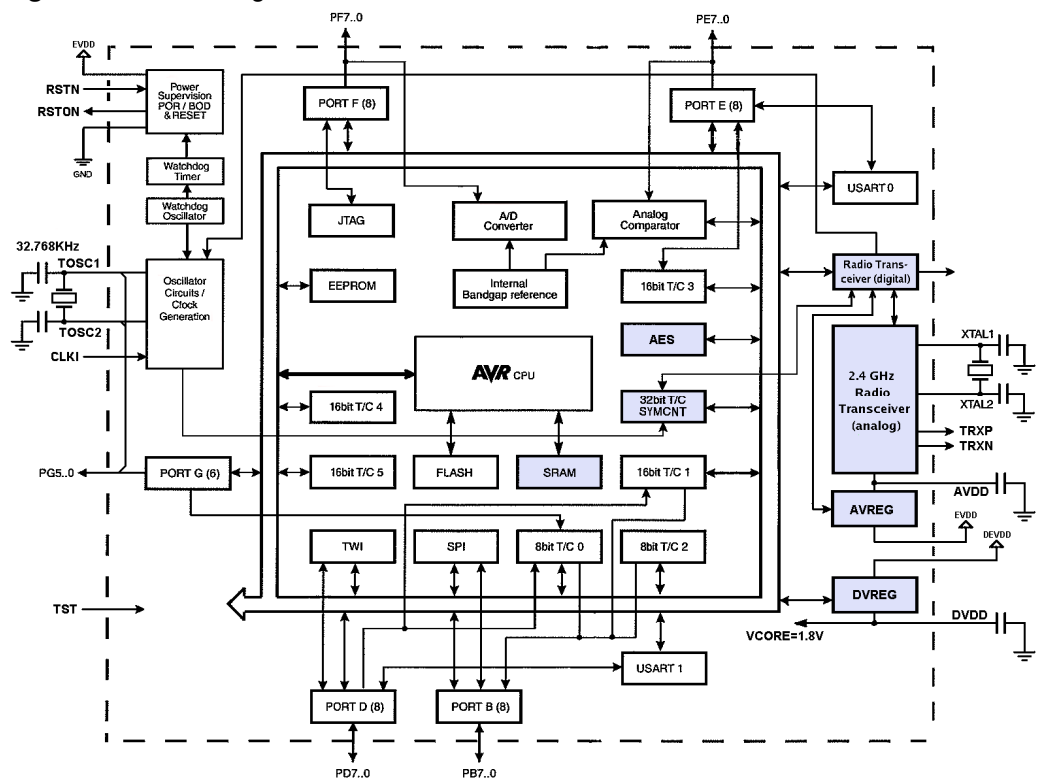

The AVR core combines a rich instruction set with 32 general purpose working registers. All 32 registers are directly connected to the Arithmetic Logic Unit (ALU). Two independent registers can be accessed with one single instruction executed in one clock cycle. The resulting architecture is very code efficient while achieving throughputs up to ten times faster than conventional CISC microcontrollers. The system includes internal voltage regulation and an advanced power management. Distinguished by the small leakage current it allows an extended operation time from battery.

The radio transceiver is a fully integrated ZigBee solution using a minimum number of external components. It combines excellent RF performance with low cost, small size and low current consumption. The radio transceiver includes a crystal stabilized fractional-N synthesizer, transmitter and receiver, and full Direct Sequence Spread



Spectrum Signal (DSSS) processing with spreading and despreading. The device is fully compatible with IEEE802.15.4-2006/2003 and ZigBee standards.

The ATmega128RFA1 provides the following features: 128 kbytes of In-System Programmable (ISP) Flash with read-while-write capabilities, 4 kbytes EEPROM, 16 kbytes SRAM, up to 35 general purpose I/O lines, 32 general purpose working registers, Real Time Counter (RTC), 6 flexible Timer/Counters with compare modes and PWM, USART, a byte oriented 2-wire Serial Interface, a 8 channel, 10 bit analog to digital converter (ADC) with an optional differential input stage with programmable gain, programmable Watchdog Timer with Internal Oscillator, a SPI serial port, IEEE std. 1149.1 compliant JTAG test interface, also used for accessing the On-chip Debug system and programming and 6 software selectable power saving modes.

The Idle mode stops the CPU while allowing the SRAM, Timer/Counters, SPI port, and interrupt system to continue functioning. The Power-down mode saves the register contents but freezes the Oscillator, disabling all other chip functions until the next interrupt or hardware reset. In Power-save mode, the asynchronous timer continues to run, allowing the user to maintain a timer base while the rest of the device is sleeping. The ADC Noise Reduction mode stops the CPU and all I/O modules except asynchronous timer and ADC, to minimize switching noise during ADC conversions. In Standby mode, the RC oscillator is running while the rest of the device is sleeping. This allows very fast start-up combined with low power consumption. In Extended Standby mode, both the main RC oscillator and the asynchronous timer continue to run.

Typical supply current of the microcontroller with CPU clock set to 16MHz and the radio transceiver for the most important states is shown in the [Figure 3-2 below](#).

Figure 3-2 Radio transceiver and microcontroller (16MHz) supply current

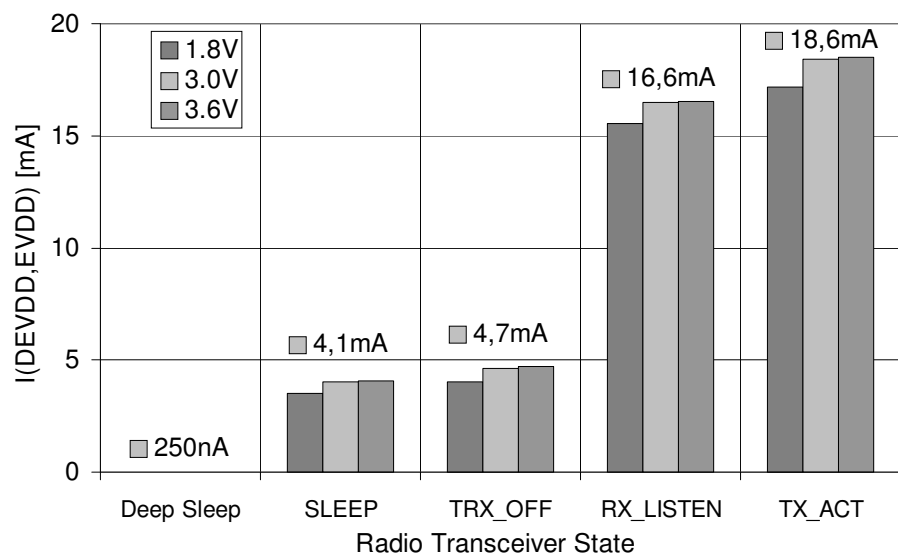

The transmit output power is set to maximum. If the radio transceiver is in SLEEP mode the current is dissipated by the AVR microcontroller only.

In Deep Sleep mode all major digital blocks with no data retention requirements are disconnected from main supply providing a very small leakage current. Watchdog timer, MAC symbol counter and 32.768kHz oscillator can be configured to continue to run.

The device is manufactured using Atmel's high-density nonvolatile memory technology. The On-chip ISP Flash allows the program memory to be reprogrammed in-system

ATmega128RFA1

through an SPI serial interface, by a conventional nonvolatile memory programmer, or by on-chip boot program running on the AVR core. The boot program can use any interface to download the application program in the application Flash memory. Software in the boot Flash section will continue to run while the application Flash section is updated, providing true Read-While-Write operation. By combining an 8 bit RISC CPU with In-System Self-Programmable Flash on a monolithic chip, the Atmel ATmega128RFA1 is a powerful microcontroller that provides a highly flexible and cost effective solution to many embedded control applications.

The ATmega128RFA1 AVR is supported with a full suite of program and system development tools including: C compiler, macro assemblers, program debugger/simulators, in-circuit emulators, and evaluation kits.

3.2 Pin Descriptions

3.2.1 EVDD

External analog supply voltage;

3.2.2 DEVDD

External digital supply voltage;

3.2.3 AVDD

Regulated analog supply voltage (internally generated);

3.2.4 DVDD

Regulated digital supply voltage (internally generated);

3.2.5 DVSS

Digital ground;

3.2.6 AVSS

Analog ground;

3.2.7 Port B (PB7...PB0)

Port B is an 8-bit bi-directional I/O port with internal pull-up resistors (selected for each bit). The Port B output buffers have symmetrical drive characteristics with both high sink and source capability. As inputs, Port B pins that are externally pulled low will source current if the pull-up resistors are activated. The Port B pins are tri-stated when a reset condition becomes active, even if the clock is not running.

Port B also provides functions of various special features of the ATmega128RFA1.

3.2.8 Port D (PD7...PD0)

Port D is an 8-bit bi-directional I/O port with internal pull-up resistors (selected for each bit). The Port D output buffers have symmetrical drive characteristics with both high sink and source capability. As inputs, Port D pins that are externally pulled low will source current if the pull-up resistors are activated. The Port D pins are tri-stated when a reset condition becomes active, even if the clock is not running.

Port D also provides functions of various special features of the ATmega128RFA1.

3.2.9 Port E (PE7...PE0)

Port E is an 8-bit bi-directional I/O port with internal pull-up resistors (selected for each bit). The Port E output buffers have symmetrical drive characteristics with both high sink and source capability. As inputs, Port E pins that are externally pulled low will source current if the pull-up resistors are activated. The Port E pins are tri-stated when a reset condition becomes active, even if the clock is not running.

Port E also provides functions of various special features of the ATmega128RFA1.

www.DataSheet4U.com





3.2.10 Port F (PF7...PF0)

Port F is an 8-bit bi-directional I/O port with internal pull-up resistors (selected for each bit). The Port F output buffers have symmetrical drive characteristics with both high sink and source capability. As inputs, Port F pins that are externally pulled low will source current if the pull-up resistors are activated. The Port F pins are tri-stated when a reset condition becomes active, even if the clock is not running.

Port F also provides functions of various special features of the ATmega128RFA1.

3.2.11 Port G (PG5...PG0)

Port G is a 6-bit bi-directional I/O port with internal pull-up resistors (selected for each bit). The Port G output buffers have symmetrical drive characteristics with both high sink and source capability. However the driver strength of PG3 and PG4 is reduced compared to the other port pins. The output voltage drop (V_{OH} , V_{OL}) is higher while the leakage current is smaller. As inputs, Port G pins that are externally pulled low will source current if the pull-up resistors are activated. The Port G pins are tri-stated when a reset condition becomes active, even if the clock is not running.

Port G also provides functions of various special features of the ATmega128RFA1.

3.2.12 AVSS_RFP

AVSS_RFP is a dedicated ground pin for the bi-directional, differential RF I/O port.

3.2.13 AVSS_RFN

AVSS_RFN is a dedicated ground pin for the bi-directional, differential RF I/O port.

3.2.14 RFP

RFP is the positive terminal for the bi-directional, differential RF I/O port.

3.2.15 RFN

RFN is the negative terminal for the bi-directional, differential RF I/O port.

3.2.16 RSTN

Reset input. A low level on this pin for longer than the minimum pulse length will generate a reset, even if the clock is not running. Shorter pulses are not guaranteed to generate a reset.

3.2.17 RSTON

Reset output. A low level on this pin indicates a reset initiated by the internal reset sources or the pin RSTN.

www.DataSheet4U.com

3.2.18 XTAL1

Input to the inverting 16MHz crystal oscillator amplifier. In general a crystal between XTAL1 and XTAL2 provides the 16MHz reference clock of the radio transceiver.

3.2.19 XTAL2

Output of the inverting 16MHz crystal oscillator amplifier;

3.2.20 AREF

Reference voltage output of the A/D Converter. In general this pin is left open.

3.2.21 TST

Programming and test mode enable pin;

3.2.22 CLKI

Input to the clock system. If selected, it provides the operating clock of the microcontroller.

3.3 Compatibility to ATmega1281/2561

The basic AVR feature set of the ATmega128RFA1 is derived from the ATmega1281/2561. Address locations and names of the implemented modules and

ATmega128RFA1

registers are unchanged as long as it fits the target application of a very small and power efficient radio system. In addition, several new features were added.

Backward compatibility of the ATmega128RFA1 to the ATmega1281/2561 is provided in most cases. However some incompatibilities between the microcontrollers exist.

3.3.1 Port A and Port C

Port A and Port C are not implemented. The associated registers are available but will not provide any port control. Remaining ports are kept at their original address location to not require changes of existing software packages.

3.3.2 External Memory Interface

The alternate pin function "External Memory interface" using Port A and Port C is not implemented due to the missing ports.

The large internal data memory (SRAM) does not require an external memory and the associated parallel interface. It keeps the system radiation (EMC) at a very small level to provide very high sensitivity at the antenna input.

3.3.3 High Voltage Programming Mode

Alternate pin function BS2 (high voltage programming) of pin PA0 is mapped to a different pin. Entering the parallel programming mode is controlled by the TST pin.

3.3.4 AVR Oscillators and External Clock

The AVR microcontroller can utilize the high performance crystal oscillator of the 2.4GHz transceiver connected to the pins XTAL1 and XTAL2. An external clock can be applied to the microcontroller using the clock input CLKI.

3.3.5 Analog Frontend

The ATmega128RFA1 has a new A/D converter. Software compatibility is basically assured. Nevertheless to benefit from the higher conversion speeds and the better performance some changes are required.



4 Application Circuits

4.1 Basic Application Schematic

A basic application schematic of the ATmega128RFA1 with a single-ended RF connector is shown in Figure 4-1 below. The 50Ω single-ended RF input is transformed to the 100Ω differential RF port impedance using Balun B1. The capacitors C1 and C2 provide AC coupling of the RF input to the RF port, capacitor C4 improves matching.

Figure 4-1. Basic Application schematic (Table 4-1 on page 9)

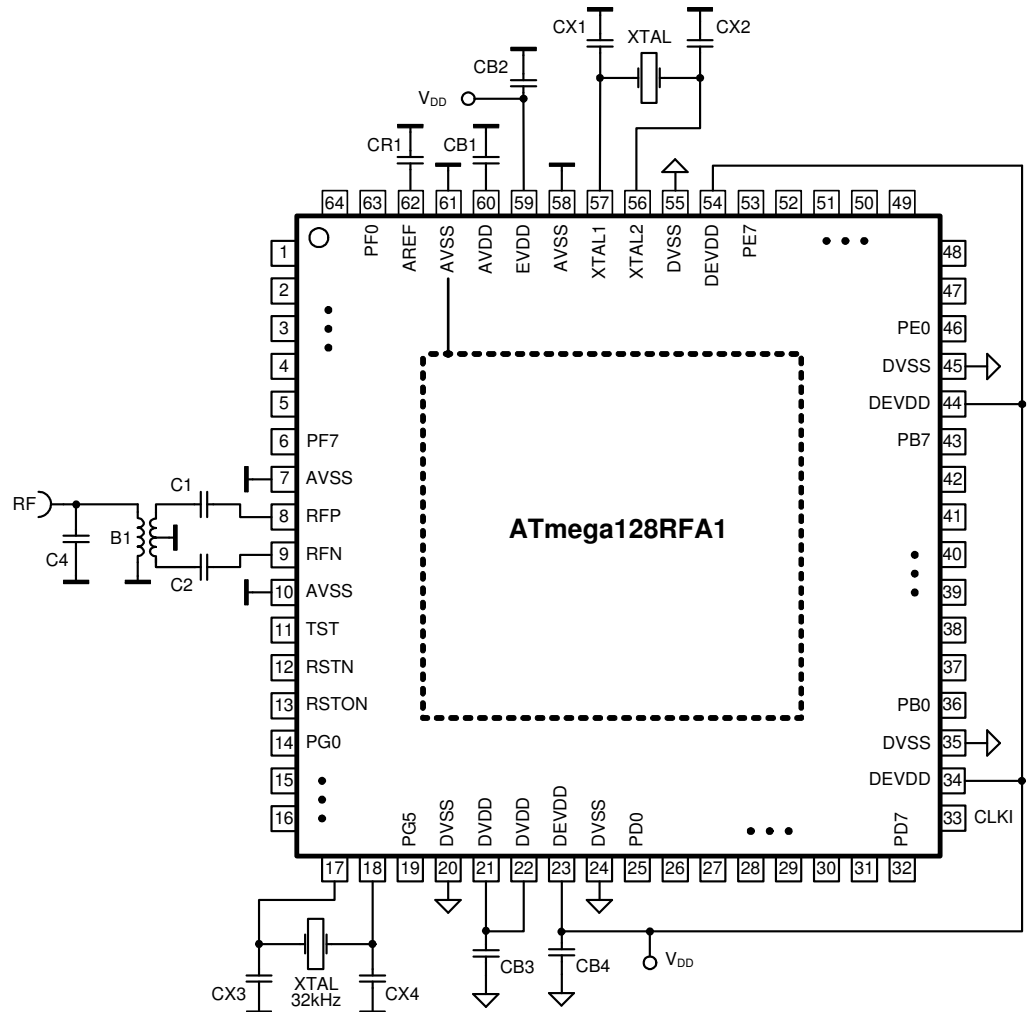

www.DataSheet4U.com

The power supply bypass capacitors (CB2, CB4) are connected to the external analog supply pin (EVDD, pin 59) and external digital supply pin (DEVDD, pin 23). Pins 34, 44 and 54 supply the digital port pins.

Capacitors CB1 and CB3 are bypass capacitors for the integrated analog and digital voltage regulators to ensure stable operation and to improve noise immunity. Capacitors should be placed as close as possible to the pins and should have a low-resistance and low-inductance connection to ground to achieve the best performance.

The crystal (XTAL), the two load capacitors (CX1, CX2), and the internal circuitry connected to pins XTAL1 and XTAL2 form the 16MHz crystal oscillator for the 2.4GHz

ATmega128RFA1

transceiver. To achieve the best accuracy and stability of the reference frequency, large parasitic capacitances must be avoided. Crystal lines should be routed as short as possible and not in proximity of digital I/O signals. This is especially required for the High Data Rate Modes.

The 32.768 kHz crystal connected to the internal low power (sub 1 μ A) crystal oscillator provides a stable time reference for all low power modes including 32 Bit IEEE 802.15.4 Symbol Counter ("[MAC Symbol Counter](#)") and real time clock application using the asynchronous timer T/C2 ("[Timer/Counter2 with PWM and Asynchronous Operation](#)"). Total capacitance including CX3, CX4 should not exceed 15pF on both pins. The very low supply current of the oscillator requires careful layout of the PCB and any leakage path must be avoided.

Crosstalk and radiation from switching digital signals to the crystal pins or the RF pins can degrade the system performance. The programming of minimum drive strength settings for the digital output signal is recommended (see "[DPDS0 - Port Driver Strength Register 0](#)").

Table 4-1. Example Bill of Materials (BoM) for "[Basic Application Schematic](#)" on page 8

Designator	Description	Value	Manufacturer	Part Number	Comment
B1	SMD balun SMD balun / filter	2.4 GHz	Wuerth Johanson Technology	748421245 2450FB15L0001	Filter included
CB1 CB3	LDO VREG bypass capacitor	1 μ F (100nF minimum)	AVX Murata	0603YD105KAT2A GRM188R61C105KA12D	X5R 10% 16V (0603)
CB2 CB4	Power supply bypass capacitor	1 μ F (100nF minimum)			
CX1, CX2	Crystal load capacitor	12 pF	AVX Murata	06035A120JA GRP1886C1H120JA01	COG 5% 50V (0603)
C1, C2	RF coupling capacitor	22 pF	Epcos Epcos AVX	B37930 B37920 06035A220JAT2A	C0G 5% 50V (0402 or 0603)
C4 (optional)	RF matching	0.47 pF	Johnstech		
R1	CLKM low-pass filter resistor	680 Ω			Designed for $f_{CLKM} = 1$ MHz
XTAL	Crystal	CX-4025 16 MHz SX-4025 16 MHz	ACAL Taitjen Siward	XWBBPL-F-1 A207-011	
XTAL 32kHz	Crystal				Rs=100 kOhm

4.2 Extended Feature Set Application Schematic

The ATmega128RFA1 supports additional features like:

- Security Module (AES)
- High Data Rate Mode up to 2Mbits/s
- Antenna Diversity using alternate pin function DIG1/2 at Port G and F
- RX/TX Indicator using alternate pin function DIG3/4 at Port G and F

An extended feature set application schematic illustrating the use of the ATmega128RFA1 Extended Feature Set, is shown in [Figure 4-2](#) on page 10.



Figure 4-2. Extended Feature Application schematic

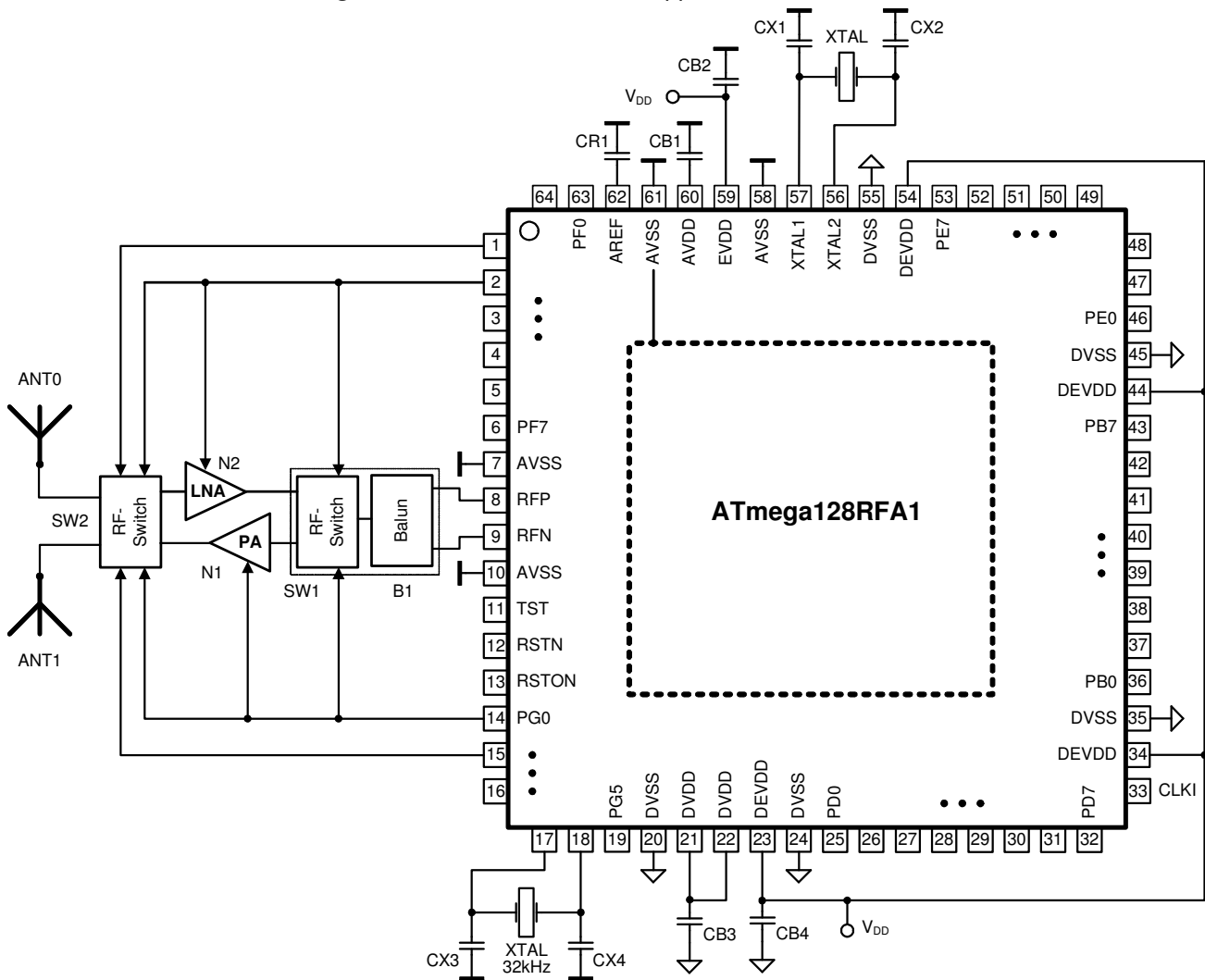

www.DataSheet4U.com

Although this example shows all additional hardware features combined, it is possible to use all features separately or in various combinations.

5 Revision history

Please note that the referring page numbers in this section are referring to this document. The referring revision in this section are referring to the document revision

Rev. 8266AS-MCU Wireless-12/09

1. Initial release



Table of Contents

1 Pin Configurations	2
2 Disclaimer	2
3 Overview	3
3.1 Block Diagram	3
3.2 Pin Descriptions.....	5
3.3 Compatibility to ATmega1281/2561	6
4 Application Circuits	8
4.1 Basic Application Schematic	8
4.2 Extended Feature Set Application Schematic.....	9
5 Revision history	11
Table of Contents	12



Headquarters

Atmel Corporation
 2325 Orchard Parkway
 San Jose, CA 95131
 USA
 Tel: 1(408) 441-0311
 Fax: 1(408) 487-2600

International

Atmel Asia
 Room 1219
 Chinachem Golden Plaza
 77 Mody Road Tsimshatsui
 East Kowloon
 Hong Kong
 Tel: (852) 2721-9778
 Fax: (852) 2722-1369

Atmel Europe
 Le Krebs
 8, Rue Jean-Pierre Timbaud
 BP 309
 78054 Saint-Quentin-en-
 Yvelines Cedex
 France
 Tel: (33) 1-30-60-70-00
 Fax: (33) 1-30-60-71-11

Atmel Japan
 9F, Tonetsu Shinkawa Bldg.
 1-24-8 Shinkawa
 Chuo-ku, Tokyo 104-0033
 Japan
 Tel: (81) 3-3523-3551
 Fax: (81) 3-3523-7581

Product Contact

Web Site
www.atmel.com

Technical Support
avr@atmel.com

Sales Contact
www.atmel.com/contacts

Literature Request
www.atmel.com/literature

Disclaimer: The information in this document is provided in connection with Atmel products. No license, express or implied, by estoppel or otherwise, to any intellectual property right is granted by this document or in connection with the sale of Atmel products. **EXCEPT AS SET FORTH IN ATMEL'S TERMS AND CONDITIONS OF SALE LOCATED ON ATMEL'S WEB SITE, ATMEL ASSUMES NO LIABILITY WHATSOEVER AND DISCLAIMS ANY EXPRESS, IMPLIED OR STATUTORY WARRANTY RELATING TO ITS PRODUCTS INCLUDING, BUT NOT LIMITED TO, THE IMPLIED WARRANTY OF MERCHANTABILITY, FITNESS FOR A PARTICULAR PURPOSE, OR NON-INFRINGEMENT. IN NO EVENT SHALL ATMEL BE LIABLE FOR ANY DIRECT, INDIRECT, CONSEQUENTIAL, PUNITIVE, SPECIAL OR INCIDENTAL DAMAGES (INCLUDING, WITHOUT LIMITATION, DAMAGES FOR LOSS OF PROFITS, BUSINESS INTERRUPTION, OR LOSS OF INFORMATION) ARISING OUT OF THE USE OR INABILITY TO USE THIS DOCUMENT, EVEN IF ATMEL HAS BEEN ADVISED OF THE POSSIBILITY OF SUCH DAMAGES.** Atmel makes no representations or warranties with respect to the accuracy or completeness of the contents of this document and reserves the right to make changes to specifications and product descriptions at any time without notice. Atmel does not make any commitment to update the information contained herein. Unless specifically provided otherwise, Atmel products are not suitable for, and shall not be used in, automotive applications. Atmel's products are not intended, authorized, or warranted for use as components in applications intended to support or sustain life.