

## VCD SIGNAL-CHIP PROCESSOR

### DESCRIPTION

SC9827 is a single chip SOC for CD-G system, it integrates CD servo and correct decoder, Audio DAC. Working with the RF pre-processor of CD composes a low cost and high performance CD-G system solution.

### FEATURES

- \* Periphery circuit is simple, servo and decoder integrated;
- \* Support CD-G decode play;
- \* Embedded Audio DAC, PWM output;
- \* JPEG decode and play function;
- \* OSD function;
- \* Adopts CD servo arithmetic, strong correct function and good coherence.

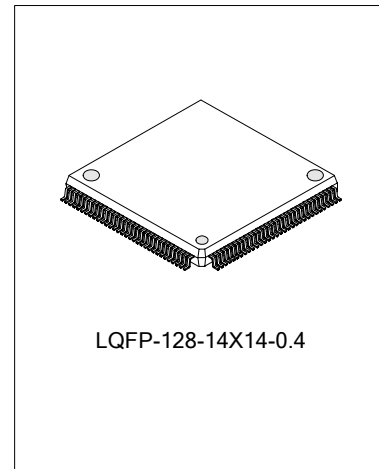

LQFP-128-14X14-0.4

### ORDERING INFORMATION

Device	Package
SC9827	LQFP-128-14x14-0.4

### APPLICATION

- \* CD-G system

### BLOCK DIAGRAM

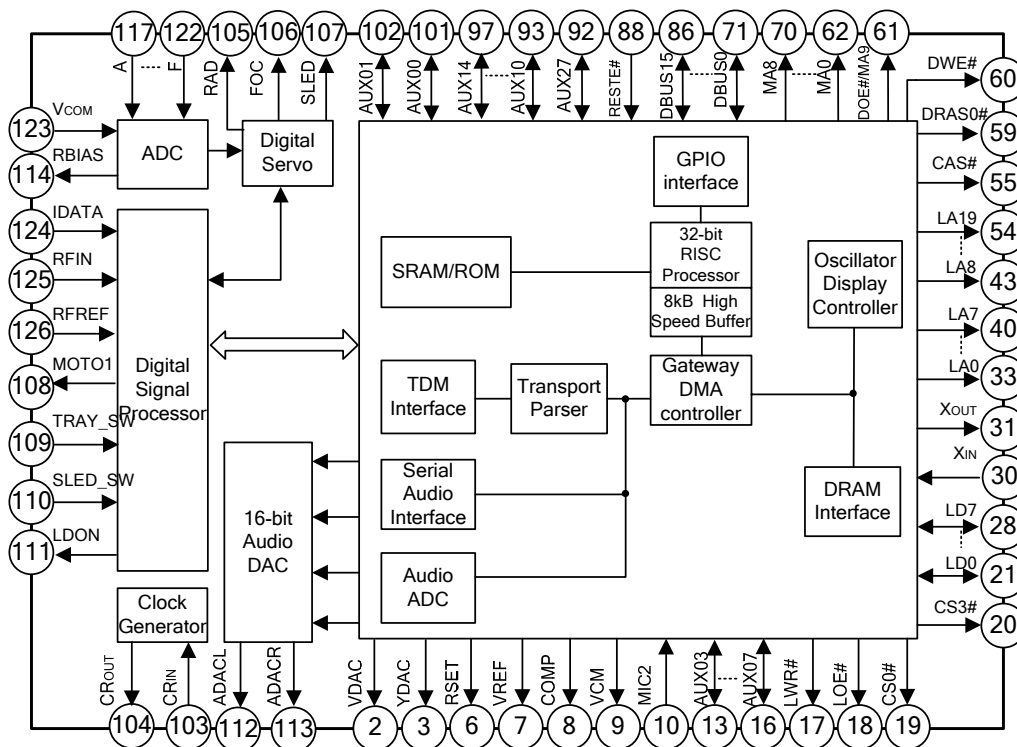

**ABSOLUTE MAXIMUM RATING**

Characteristics	Symbol	Rating	Unit
Power Supply Voltage	VDD	-0.5 ~ +5.5	V
Input Voltage on Pins	VIN	-0.5 ~VDD + 0.5	V
Operating Temperature	Topr	-20 ~ +75	°C

**ELECTRICAL CHARACTERISTICS** (unless otherwise specified, Tamb=25°C)

Characteristics	Symbol	Test conditions	Min.	Typ.	Max.	Unit
Operating Voltage	VDD		4.5	5	5.5	V
Operating Current	IDD		48	50	52	mA
Quiescent Current	IDD(q)	VDD=5V; Tamb=25°C	--	--	300	μA
Operating Temperature	Tamb	VDD=5V; Tamb=25°C	-10	--	+80	°C
DA output Distortion	(THD+N)/S	0dB 1KHz signal input	-	-65	-	dB
DA output Signal to Noise	S/N	No signal input	-	75	-	dB

PIN CONFIGURATION

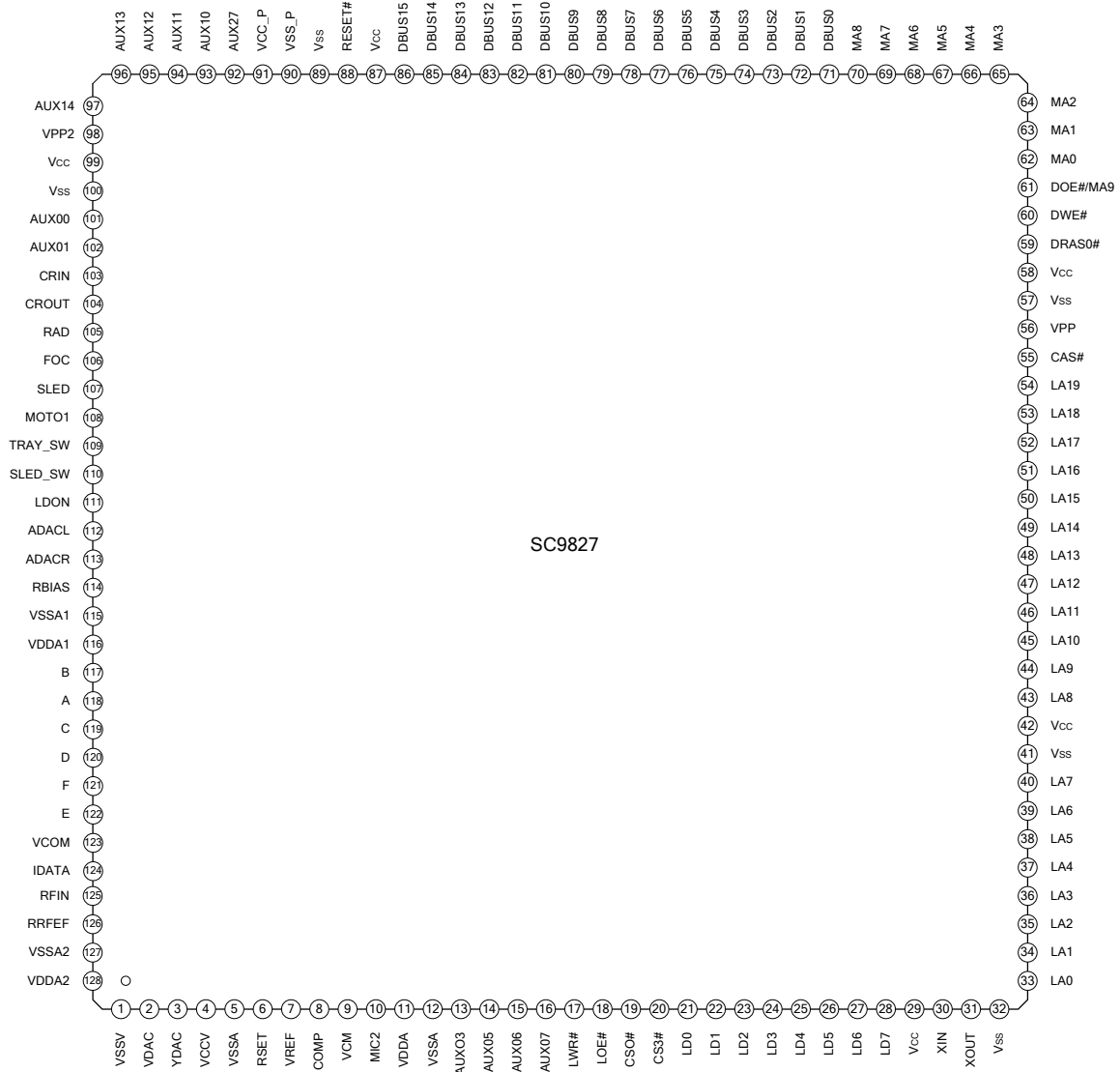

**PIN DESCRIPTION**

Pin no.	Pin name	I/O	Function
1	VSSV	I	Analog ground.
2	VDAC	O	Video DAC V port output.
3	YDAC	O	Video DAC Y port output.
4	VCCV	I	Analog power supply. 2.5V
5, 12	VSSA	I	Analog ground.
6	RSET	O	Reset the internal current of generator; connect with a 510Ω resistor to ground.
7	VREF	O	Output reference voltage, connect a 0.01μF high frequency filter capacitor to VSSA.
8	COMP	O	Compensation capacitance for low-pass filter on VDAC. Connect to a 0.01μF high-frequency bypass capacitor to VSSA.
9	VCM	O	ADC analog reference voltage, connect to a 0.01μF high frequency filter capacitor to VSSA.
10	MIC2	I	Microphone input.
11	VDDA	I	Analog 5.0V power supply.
13	AUX03	I/O	General-purpose programmable I/O.
14~16	AUX0[5:7]	I/O	General-purpose programmable I/O.
17	LWR#	O	RISC interface writable (low active).
18	LOE#	O	RISC static memory output (low active).
19	CS0#	O	Chip select 0 for SRAM.
20	CS3#	O	Chip select 3 for SRAM.
21~28	LD[0:7]	I/O	Data bus.
29	Vcc	I	Main power supply 2.5V
42			
58			
87			
99			
30	XIN	I	27MHz crystal oscillator input, the duty is 50%.
31	XOUT	O	Input clock crystal oscillator output.
32	VSS	I	Main ground.
41			
57			
89			
100			
33~40	LA[0:7]	O	Address bus.
43~54	LA[8:19]	O	Address bus.
55	CAS#	O	Column address filter to dynamic memory (low active).
56	VPP	I	5V power supply.
59	DRAS0#	O	Row address filter to dynamic memory.
60	DWE#	O	Writable dynamic memory (low active).

Pin no.	Pin name	I/O	Function
61	DOE#/MA9	O	Output data to dynamic memory (low active), Multivariate memory row and column address.
62~70	MA[0:8]	O	Multivariate memory row and column address.
71~86	DBUS[0:15]	I/O	Input/output when Dynamic memory read/write.
88	RESET#	I	External system reset will make ES3890 reset.
90	VSS_P	I	PLL system ground.
91	VCC_P	I	PLL system 2.5V power supply.
92	AUX27	I/O	General-purpose programmable I/O.
93~97	AUX1[0:4]	I/O	General-purpose programmable I/O.
98	VPP2	I	5V power supply.
101~102	AUX0[0:1]	I/O	General-purpose programmable I/O.
103	CRIN	I	8M crystal oscillator input of Servo unit.
104	CROUT	O	8M crystal oscillator output of Servo unit.
105	RAD	O	Tracking driver signal.
106	FOC	O	Focus driver signal.
107	SLED	O	Sled motor driver signal.
108	MOTO1	O	Spindle motor driver signal.
109	TRAY_SW	I	Tray position monitor signal input.
110	SLED_SW	I	Sled motor position monitor signal input.
111	LDON	O	Laser control signal output.
112	ADACL	O	Audio DAC left channel output.
113	ADACR	O	Audio DAC right channel output.
114	RBIAS	O	Internal resistor adjust.
115	VSSA1	I	Analog ground 1 for servo unit.
116	VDDA1	I	Analog power supply 1 for servo unit.
117	B	I	Central diode current signal input 1
118	A	I	Central diode current signal input 2
119	C	I	Central diode current signal input 3
120	D	I	Central diode current signal input 4
121	F	I	Satellite diode current signal input
122	E	I	Satellite diode current signal input
123	VCOM	I	DC voltage input pin
124	IDATA	I	Output feedback current of data signal.
125	RFIN	I	CD pick up signal input.
126	RFREF	I	CD pick up signal reference voltage.
127	VSSA2	I	Analog ground 2 for servo unit.
128	VDDA2	I	Analog power supply 2 for servo unit.

**FUNCTION DESCRIPTION**

SC9827 is a single chip SOC for CD-G system, it integrates CD servo and correct decoder, Audio DAC. Working with the RF pre-processor of CD composes a low cost and high performance CD-G system solution.

**CD servo decode module**

CD servo decoder is the main module of SC9827, it can perform the CD servo and decode function, and support single/double speed switch, compatible with CD/CD-R/CD-RW/CD-G.

**Audio DAC module**

This unit is 16 bits audio DAC, output PWM waveform, and connect to low-filter.

**CD-G decode module**

This module has CD-G decode functions.

**TYPICAL APPLICATION CIRCUIT**

