



310-001 O-Ring Sealed Shrink Boot Adapter Rotatable Coupling - Standard Profile

Connector Designators:

MIL-DTL-38999 Series I, II (F)
MIL-DTL-38999 Series III and IV (H)

F-H ROTATABLE COUPLING

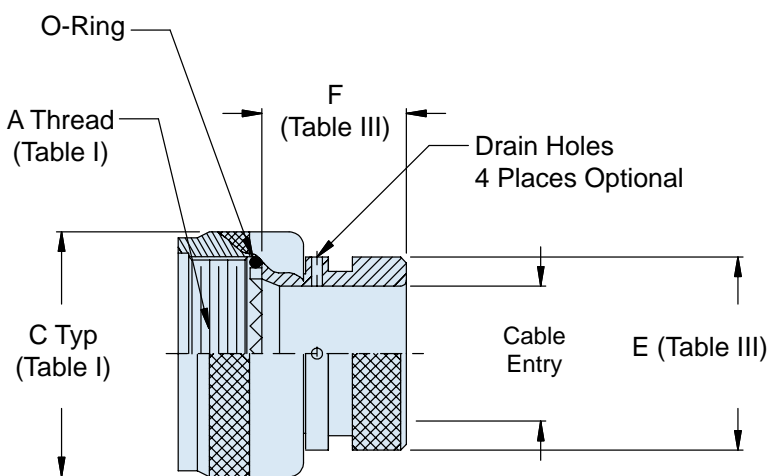
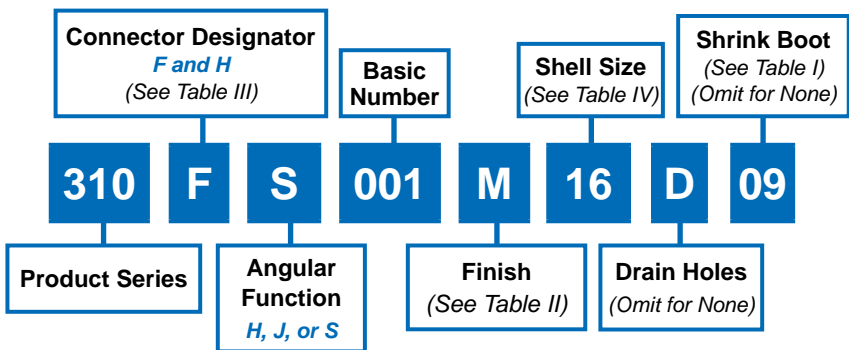
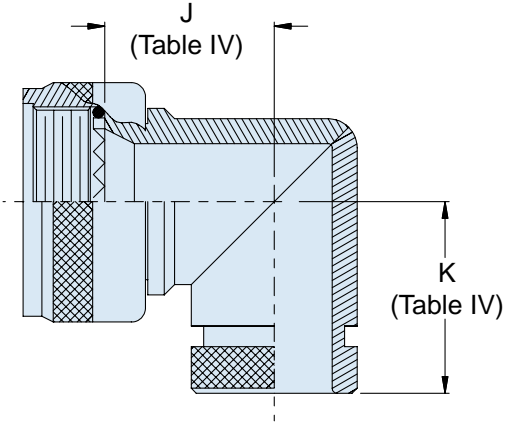
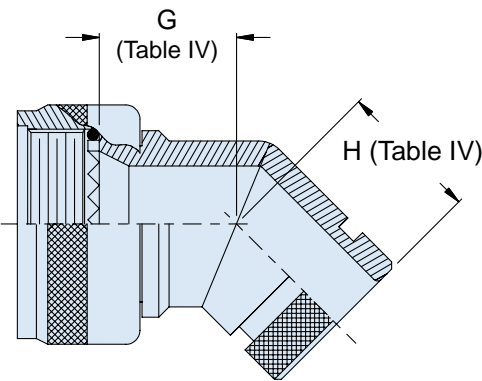

TABLE II: FINISHES

Symbol	Finish
B	Cadmium Plate, Olive Drab
C	Anodize, Black
GB	Black Anodize, Hard Coat
M	Electroless Nickel
N	Cad Plate, Olive Drab over Electroless Nickel
NF	Cadmium Plate, Olive Drab over Electroless Nickel
MT	Ni-PTFE 1000 Hour Grey™ Nickel Fluorocarbon Polymer
Z1	Stainless Steel Passivate
ZL	CRES, Electroless Nickel
ZN	Zinc-Nickel



310-001
O-Ring Sealed Shrink Boot Adapter
Rotatable Coupling - Standard Profile



TABLE III: CABLE ENTRY AND SHRINK BOOT

Connector Designator F	Connector Designator H	E Max	F Max	Cable Entry Min	Shrink Boot*
08	09	.533 (13.5)	.940 (23.9)	.250 (6.4)	770-003S102
10	11	.605 (15.4)	.940 (23.9)	.355 (9.0)	770-001S103
12	13	.774 (19.7)	.940 (23.9)	.491 (12.5)	770-001S103
14	15	.838 (21.3)	.940 (23.9)	.565 (14.4)	770-001S103
16	17	.963 (24.5)	.940 (23.9)	.690 (17.5)	770-001S104
18	19	1.042 (26.5)	.940 (23.9)	.769 (19.5)	770-001S104
20	21	1.217 (30.9)	.940 (23.9)	.894 (22.7)	770-001S106
22	23	1.355 (34.4)	.940 (23.9)	1.019 (25.9)	770-001S107
24	25	1.443 (36.7)	.940 (23.9)	1.134 (28.8)	770-001S107
28	29	1.709 (43.4)	.940 (23.9)	1.369 (34.8)	770-001S108
32	33	1.919 (48.7)	1.005 (25.5)	1.615 (41.0)	770-001S108

TABLE IV: BACKSHELL DIMENSIONS

Connector Designator F	Connector Designator H	G Max	H Max	J Max	K Max
08	09	.639 (16.2)	.810 (20.6)	.750 (19.1)	.920 (23.4)
10	11	.664 (16.9)	.840 (21.3)	.810 (20.6)	.980 (24.9)
12	13	.688 (17.5)	.860 (21.8)	.870 (22.1)	1.040 (26.4)
14	15	.705 (17.9)	.890 (22.6)	.920 (23.4)	1.110 (28.2)
16	17	.732 (18.6)	.910 (23.1)	.980 (24.9)	1.170 (29.7)
18	19	.748 (19.0)	.920 (23.4)	1.020 (25.9)	1.190 (30.2)
20	21	.773 (19.6)	.940 (23.9)	1.080 (27.4)	1.250 (31.8)
22	23	.800 (20.3)	.980 (24.9)	1.140 (29.0)	1.330 (33.8)
24	25	.823 (20.9)	1.010 (25.7)	1.200 (30.5)	1.400 (35.6)
28	29	1.041 (26.4)	1.180 (30.0)	1.480 (37.6)	1.640 (41.7)
32	33	1.092 (27.7)	1.370 (34.8)	1.610 (40.9)	1.880 (47.8)

APPLICATION NOTES

1. See shrink boot reference information (Page G-5).
2. O-Rings not supplied with drain hole option.
3. O-Rings not supplied with Connector Designators A and G.
4. Metric dimensions (mm) indicated in parentheses.

