



LIGITEK ELECTRONICS CO.,LTD.
Property of Ligitek Only

LED SMD



Lead-Free Parts

LG-008DUYS-CT-L1-A01

DATA SHEET

DOC. NO : QW0905-LG-008DUYS-CT-L1-A01

REV. : A

DATE : 21 - Aug. - 2007



Features:

- 1. Side view Yellow LED.
- 2. White SMT package.
- 3. Leadframe package with individual 2 pin.
- 4. Wide viewing angle.
- 5. Soldering methods: IR reflow soldering.
- 6. Feature of the device: more light due to higher optical efficiency; extremely wide viewing angle; ideal for backlighting and coupling in light guide.
- 7. Pb free

Applications:

- 1. LCD back light.
- 2. Mobile phones.
- 3. Indicators.
- 4. Switch lights.

Device Selection Guide:

PART NO	MATERIAL	COLOR	
		Emitted	Lens
LG-008DUYS-CT-L1-A01	AlGaInP	Yellow	Water Clear



Package Dimensions

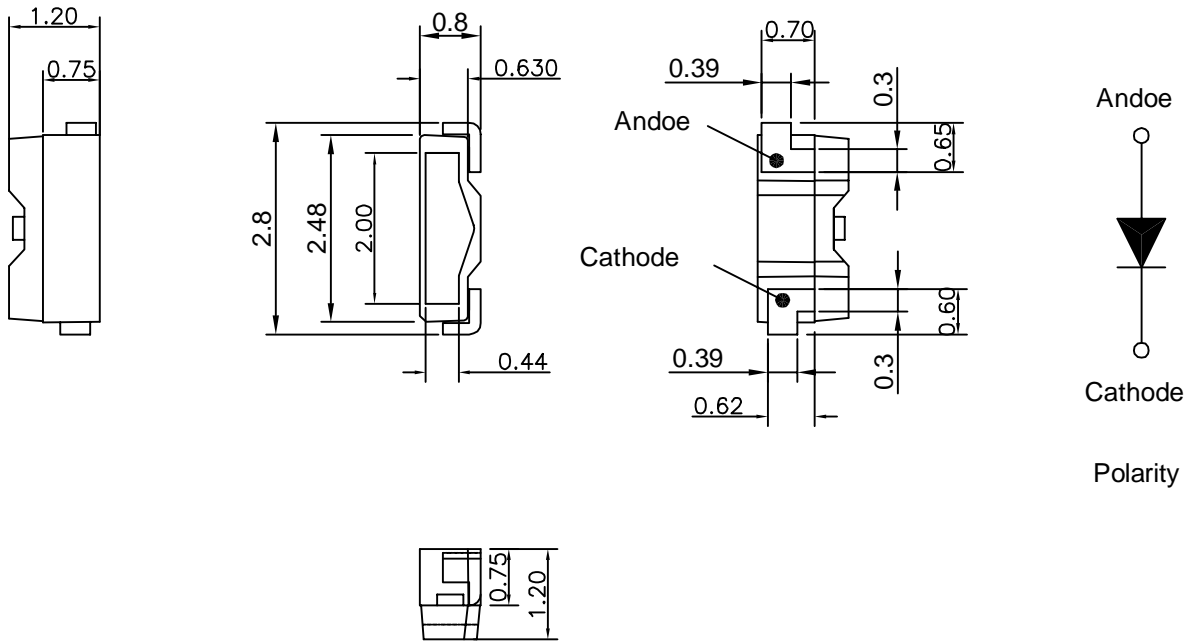

Note : 1.All dimension are in millimeter tolerance is ± 0.1 mm unless otherwise noted.
2.Specifications are subject to change without notice.

Recommended Soldering Pad Dimensions

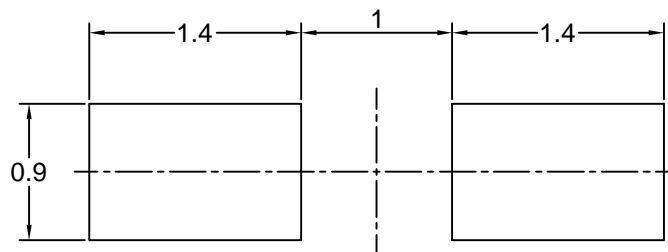

Note : The tolerances unless mentioned is ± 0.1 mm, Angle ± 0.5 . Unit=mm.

**Absolute Maximum Ratings at Ta=25**

Parameter	Symbol	Ratings	UNIT
Power Dissipation	PD	78	mW
Peak Forward Current Duty 1/10@10KHz	IFP	60	mA
Forward Current	IF	30	mA
Reverse Current @5V	Ir	10	μ A
Electrostatic Discharge	ESD	2000	V
Operating Temperature	T _{opr}	-40 ~ +85	
Storage Temperature	T _{stg}	-40 ~ +90	
Soldering Temperature	T _{sol}	Max 260 for 5 sec Max	

Typical Electrical & Optical Characteristics (Ta=25)

Items	Symbol	Min.	Typ.	Max.	Unit	Condition
Luminous Intensity	I _v	400	450	----	mcd	IF=20mA
Peak Wavelength	P	----	595	----	nm	IF=20mA
Domainant Wavelength	D	588	590	592	nm	IF=20mA
Spectral Line Half-Width		----	15	----	nm	IF=20mA
Forward Voltage	V _F	1.9	----	2.5	V	IF=20mA
Viewing Angle	2 1/2	----	115	----	deg	IF=20mA

Note : 1.The forward voltage data did not including $\pm 0.1V$ testing tolerance.
2. The luminous intensity data did not including $\pm 10\%$ testing tolerance.



Luminous Intensity Classification (at 20mA)

Rank	BIN CODE	Iv(mvd)	
		Min.	Max.
T	T4	410	440
	T5	440	470
	T6	470	500
U	U1	500	530
	U2	530	560
	U3	560	590

Forward Voltage Classification (at 20mA)

BIN CODE	Vf(v)	
	Min.	Max.
1	1.9	2.0
2	2.0	2.1
3	2.1	2.2
4	2.2	2.3
5	2.3	2.4
6	2.4	2.5

Chromaticity Coordinates Specifications For Bin Grading

BIN CODE	Hue (nm)	
	Min.	Max.
16	587	589
17	589	592



Typical Electro-Optical Characteristics Curve DUYS CHIP

Fig.1 Forward current vs. Forward Voltage

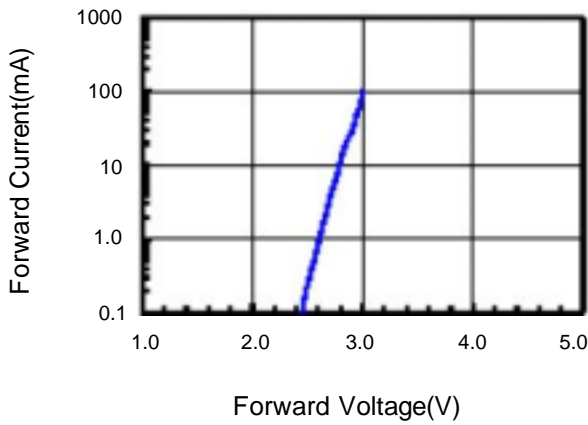

Fig.2 Relative Intensity vs. Forward Current

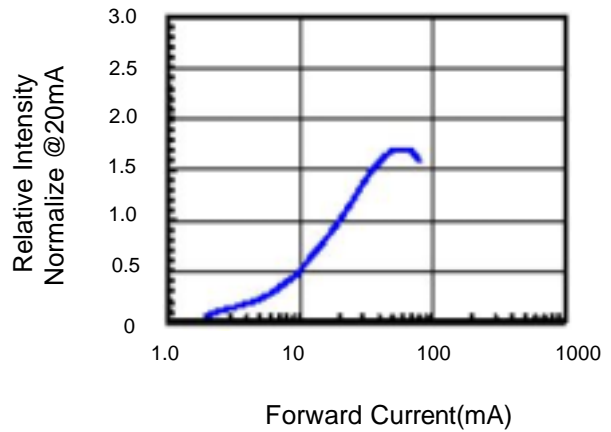

Fig.3 Forward Voltage vs. Temperature

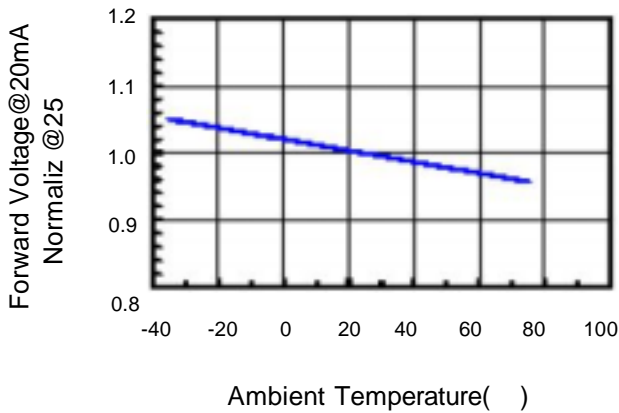

Fig.4 Relative Intensity vs. Temperature

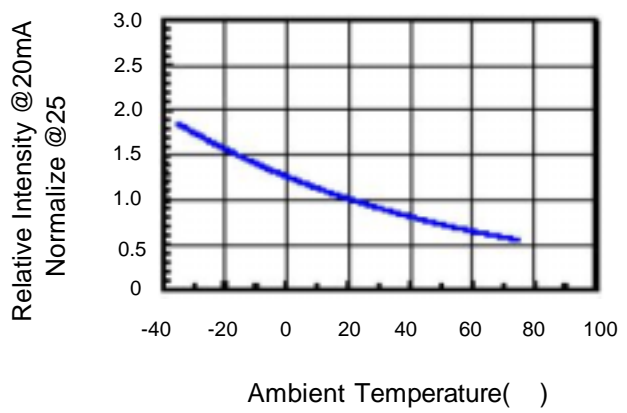

Fig.5 Relative Intensity vs. Wavelength

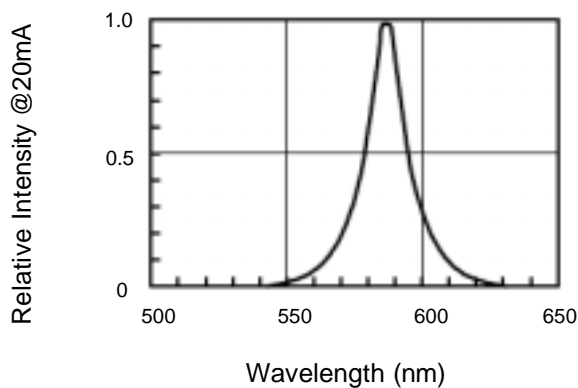
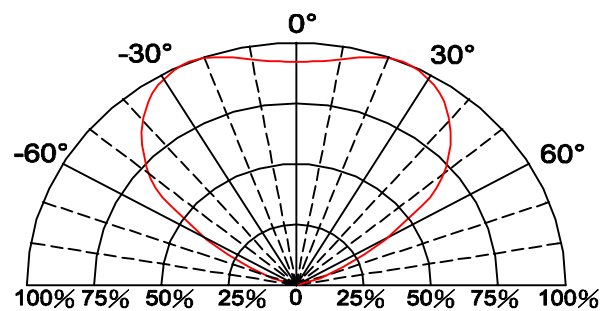
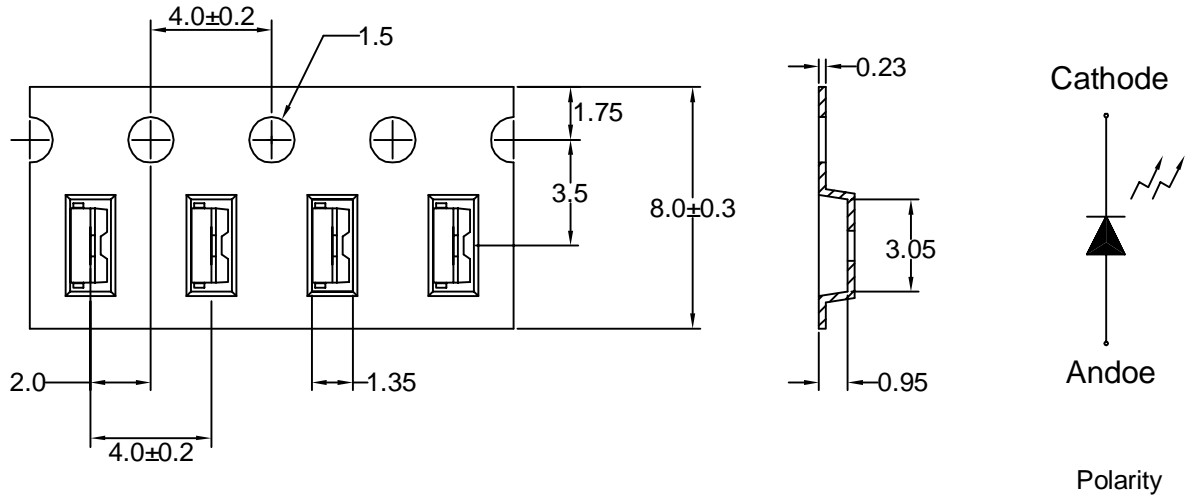

Fig.6 Directive Radiation





Carrier Type Dimensions



Note : The tolerances unless mentioned is $\pm 0.1\text{mm}$, Angle ± 0.5 . Unit=mm.

Packing Specifications

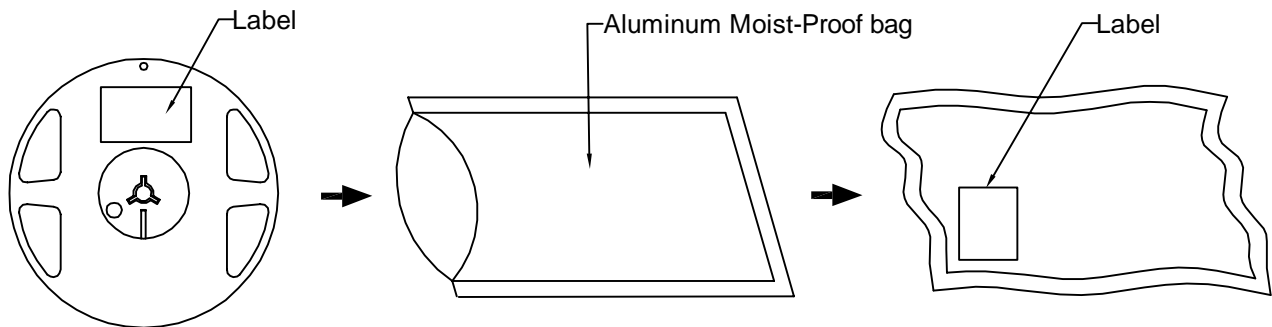

Part No.	Description	Quantity/Reel
LG-008DUYS-CT-L1-A01	8.0mm tape,7"reel	3000 devices



Label Explanation

 立碁電子工業股份有限公司 LIGITEK ELECTRONICS CO., LTD.		
PART NO. : LG-008DUYS-CT-L1-A01		
LOT NO. : MC9500126		
Q'TY(PCS) : 3000 PCS		
BIN/HUE : T5 / 17		2.1 - 2.2

BIN : Luminous Intensity

HUE : Dominant Wavelength

1.8 - 2.0 : Forward Voltage

Reel Dimensions

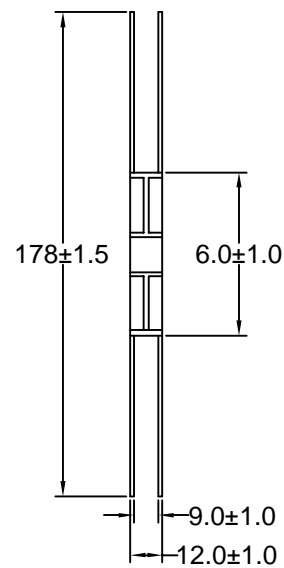
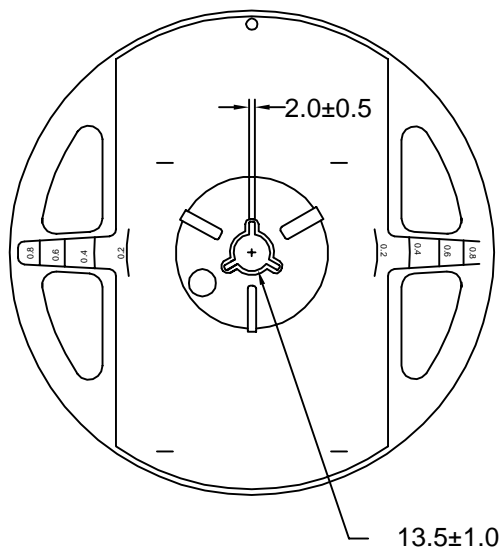



Box Explanation

- 1. 5 BAG / INNER BOX
- 2. INNER BOX SIZE : L X W X H 23cm X 8.5cm x 26cm

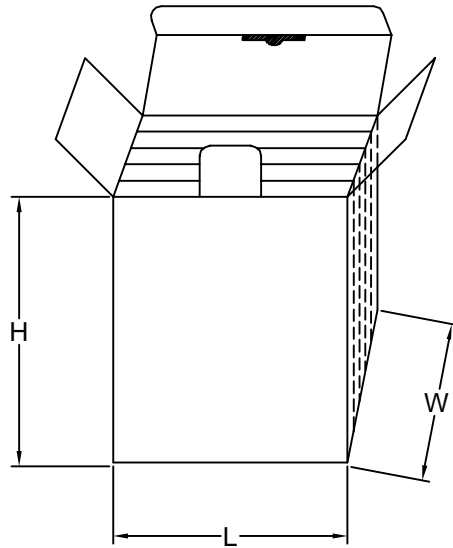

- 3. 10 INNER BOXES / CARTON
- 4. CARTON SIZE : L X W X H 49cm X 46cm x 29cm

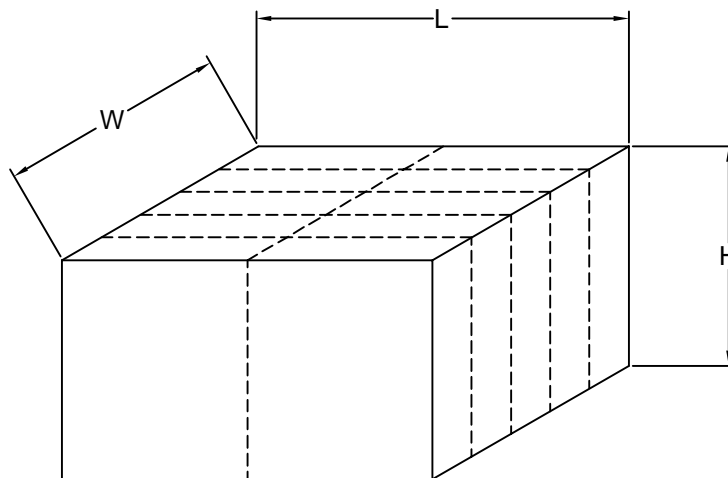



Soldering Iron:

Basic spec is 5 seconds when 260 .
Power dissipation of iron should be smaller than 25W,and temperature should be controllable.
Surface temperature of the device should be under 280 for 3 seconds.

Reflow Temp/Time(Pb-free)

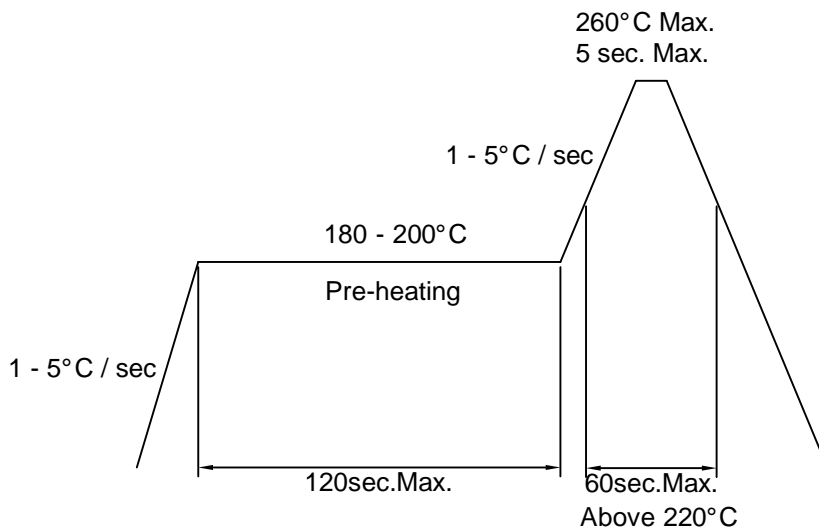

Reflow Temp/Time(Lead solder)

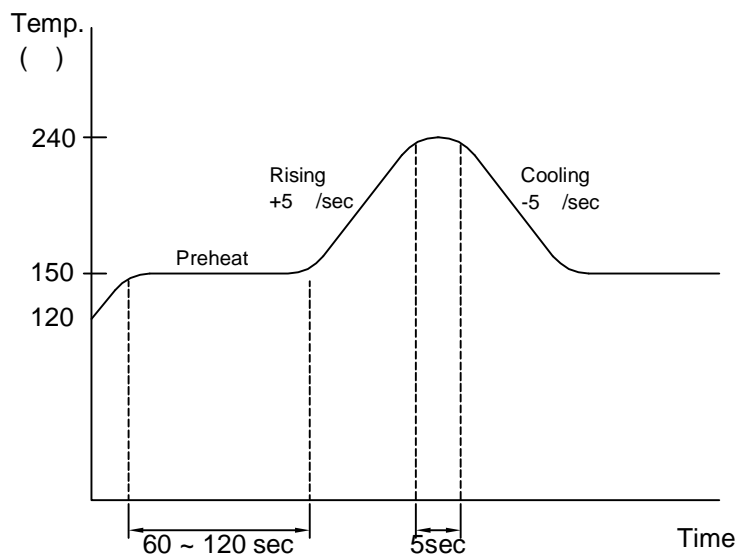

Note:

- 1.Reflow soldering should not be done more than two times.
- 2.When soldering,do not put stress on the LEDs during heating.
- 3.After soldering,do not warp the circuit board.



Precautions For Use:

Storage time:

- 1.The operation of Temperatures and RH are : 5 ~35 ,RH60%.
- 2.Once the package is opened, the products should be used within a week.
Otherwise, they should be kept in a damp proof box with descanting agent.
Considering the tape life, we suggest our customers to use our products within a year(from production date).
- 3.If opened more than one week in an atmosphere 5 ~ 35 ,RH60%, they should be treated at 60 ±5 fo r 15hrs.

Drive Method:

LED is a current operated device, and therefore, requirer some kind of current limiting incorporated into the driver circuit. This current limiting typically takes the form of a current limiting resistor placed in series with the LED.

Consider worst case voltage variations than could occur across the current limiting resistor. The forward current should not be allowed to change by more than 40 % of its desired value.

Circuit model A

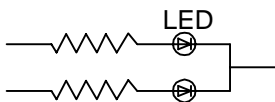

Circuit model B

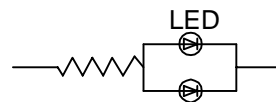

- (A) Recommended circuit.
- (B) The difference of brightness between LED could be found due to the VF-IF characteristics of LED.

Cleaning:

Use alcohol-based cleaning solvents such as isopropyl alcohol to clean the LED.

ESD(Electrostatic Discharge):

Static Electricity or power surge will damage the LED. Use of a conductive wrist band or anti-electrosatic glove is recommended when handing these LED. All devices, equipment and machinery must be properly grounded.

**Reliability Test:****(1)Test items and results**

Classification	Test Item	Test Condition	Sample Size
Endurance Test	Operating Life Test	1.Ta=Under Room Temperature As Per Data Sheet Maximum Rating. 2.If=20mA 3.t=1000 hrs	22
	High Temperature Storage Test	1.Ta=105 ±5 2.t=1000 hrs	22
	Low Temperature Storage Test	1.Ta=-40 ±5 2.t=1000 hrs	22
	High Temperature High Humidity Storage Test	1.IR-Reflow In-Board, 2 Times 2.Ta=60 ±5 3.RH=90%~95% 4.t=1000 hrs±2hrs	22
Environmental Test	Thermal Shock Test	1.IR-Reflow In-Board,2 times 2.Ta=105 ±5 & -40 ±5 (30min) (30min) 3.total 100 cycles	22
	Reflow Soldering Test	1.T.Sol=260 ±5 2.Dwell Time= 10 Max.	22
	Temperature Cycling	1.105 ~ 25 ~ -40 30mins 15mins 30mins 2.100 Cyeles	22

(2)Criteria for judging the damage

Item	Symbol	Test Conditions	Criteria for Judgement	
			Min.	Max.
Forward Voltage	Vf	If=20mA	-	U.S.L x1.2
Reverse Current	Ir	Vr=5V	-	U.S.L x2.0
Luminous Intensity	Iv	If=20mA	L.S.L x 0.5	-

Note:

- 1.U.S.L.:Upper Standard Level.
- 2.L.S.L.:Lower Standard Level.