



O/E/N 53

HEAVY DUTY RELAY

FEATURES

- High Performance
- Heavy duty up to 70Amps
- 6.3mm Flat terminals
- Suitable Couplers available
- Dual Contacts

APPLICATION

- A/C Blower
- A/C Compressor
- Engine Cooling Fan
- Radiator Fan
- Starter Motors
- Rear Window Defogger
- Battery Disconnection

TECHNICAL DATA FOR CONTACT SIDE :

Model	:	53SO	53DO	53TO
		RESISTIVE /INDUCTIVE/CAPACITIVE LOADS		
Areas of Application				
Contact Configuration	:	1A	1A (Dual)	1A (Dual)
Contact Material	:	Silver Nickel	Silver Nickel	Silver Nickel / Tungsten*
Contact Rating at 25°C - 12VDC (Res.)	:	40A	50A	70A
24VDC (Res.)	:	20A	25A	35A
Electrical Life Operations Min.	:	1 x 10 ⁵	1 x 10 ⁵	1 x 10 ⁵
Mechanical Life Operations Min.	:	1 x 10 ⁶	1 x 10 ⁶	1 x 10 ⁶
Contact Voltage Drop at 10 A (Min)	:	30mV	30mV	30mV
Maximum Switching Current @ 12.8 VDC For 3 Sec.	:	120A	150A	240A

*Dual Contact with Tungsten pre-contact / Silver nickel main contact

www.DataSheet4U.com

GENERAL DATA FOR COIL SIDE

Nominal Coil Power	:	1.92W (Approx)
Operating Power	:	1.1W (Approx)
Operate Time**	:	15 milli Seconds
Release Time**	:	15 milli Seconds

** At nominal voltage without coil suppression (excluding bounce)

OPERATING CONDITIONS

Ambient Temperature	:	-25°C to +85°C
Maximum Temperature	:	155°C
Dielectric Strength	:	500VRMS
Insulation Resistance	:	100 Meg. Ohms Min. At 500 VDC, 25°C RH 50
Vibration Resistance (without Change in the switching state > 10μS)	:	10-50Hz 4.4g (min)
Shock Resistance (without Change in the switching state > 10μS)	:	30g, 8mS

CIRCUIT DIAGRAM

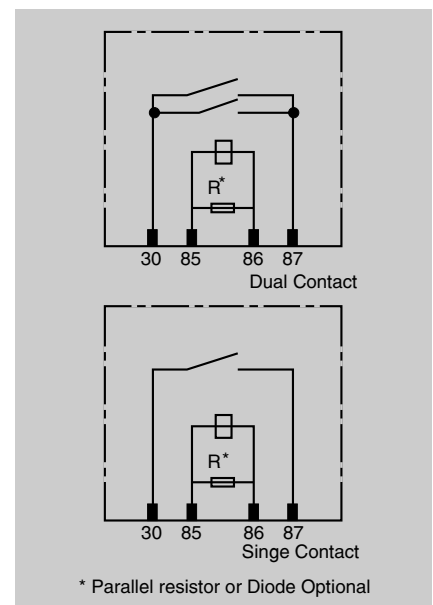

HOW TO ORDER

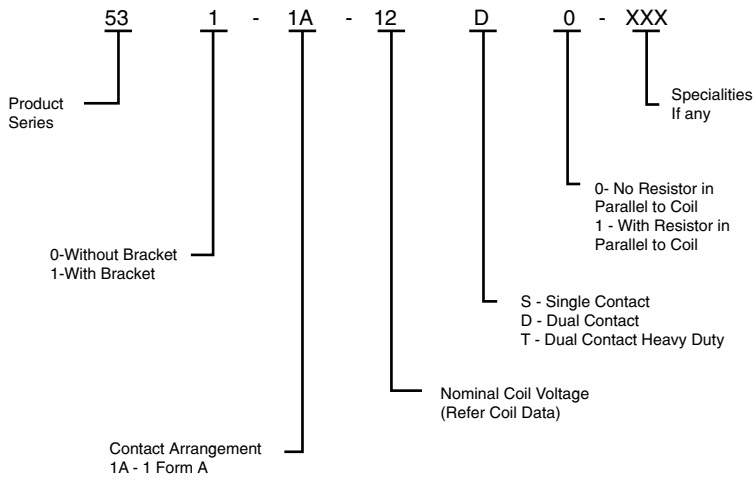

COIL DATA

Nominal Voltage VDC	***Pick-up Voltage VDC Version D	Pick-up Voltage VDC Version T	Coil Resistance without parallel resistor in Ohms ±10%
06	4.8	5.2	20
09	6.8	7.2	55
12	9.0	9.6	75
18	13.5	14.4	165
24	18.0	19.2	250
48	36.0	38.4	1100

***Lower pick-up Voltages available on request

DIMENSIONS

Relay without Bracket

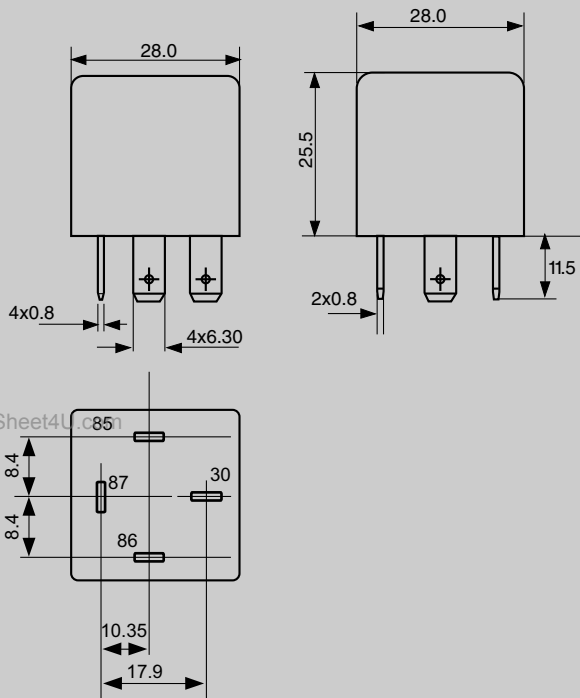

Relay with Bracket

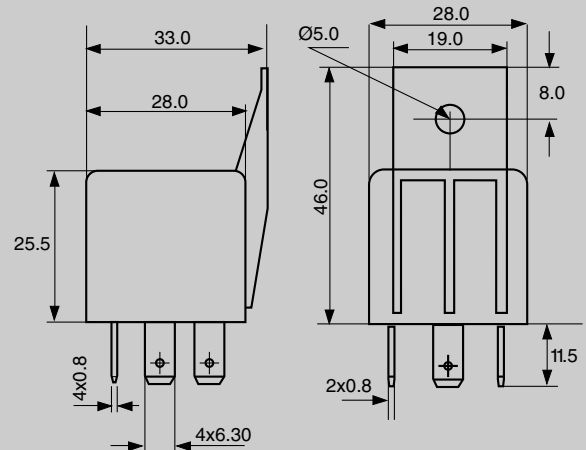

MECHANICAL DATA

COVER RETENTION

Pull : 20KgF

Push : 20KgF

TERMINAL STRENGTH

Pull : 10KgF

Push : 10KgF

AVAILABLE ON REQUEST

- High temperature winding wire
- Special coil resistance & pick-up
- For other custom solutions consult factory

DATA ON VARIOUS TESTS CONDUCTED FOR OPERATING CONDITIONS *

TEST	TEST CONDITION	RESULT
Continuous Energisation test at Extreme temperature Conditions	Relay kept at 100°C Coil Voltage : 14 VDC Load given : 25 A @ 12 VDC Duration : 5 Sec. On, 5 Sec. OFF No. of operation : 50000 The above test repeated at - 30°C for 50000 operations	Relays successfully completed 100000 operations at given load
Thermal cycling	Relay subjected to :- -30°C to + 100°C in 2 Hrs. with coil ON +100°C for 2 Hrs. with coil ON +100°C to - 30°C in 2 Hrs. with 1 Hrs. Coil ON & 1 Hrs. Coil OFF -30°C for two Hrs. with Coil ON No. of Cycles : 3	All operating parameters within the specifications after test
Shock Voltage	Relay is subjected to :- Max. Voltage : 100VDC Shock Wave : Exponential Damping vibration Time : 500 micro Sec. Period : 30 Sec. Test Time : 10 Hrs.	After the test, all operating parameters of the relay are within specification.
Dropping Impact	Relays dropped from a height of 1 Meter to a concrete floor	No change in operating parameters of the relay.
Jump Start	24 VDC for 1 minute conducting nominal current at 23°C	Withstood successfully
Corrosion Resistance	5% Sodium Chloride solution applied to relay for 48 Hrs.	No damage to relay parts
Water Resistance test	Horizontal Plane:23rev. / Min. Water Pressure:0.03 Mpa Test time:10 Min	No water ingress inside the relay

*Typical values for relays with 12 VDC coil. For higher severity please consult factory

All Parameters except the load given are same for 53 & 53PT Relays.