

High Performance Appliance Motor Control IC

Features

- **MCE™(Motion Control Engine) - Hardware based computation engine for high efficiency sinusoidal sensorless control for Permanent Magnet AC motors**
- **Built-in hardware peripheral for single shunt current feedback reconstruction**
- **Supports both interior and surface permanent magnet motor sensorless control**
- **No external current or voltage sensing OP amp circuit required**
- **Loss minimization Space Vector PWM**
- **Three-channel analog output (PWM)**
- **Embedded 8-bit high speed microcontroller (8051) for flexible I/O and man-machine control**
- **JTAG programming port for emulation/debugger**
- **Serial communication interface (UART)**
- **I²C/SPI serial interface**
- **Three general purpose timers/counters**
- **Three special timers: watchdog timer, periodic timer, capture timer**
- **Three general purpose timers/counters**
- **External EEPROM and internal RAM facilitates debugging and code development**
- **Pin compatible with OTP ROM version**

Product Summary

Maximum clock input (f_{crystal})	60 MHz
Maximum internal clock (SYSCLK)	128 MHz
Sensorless control computation time	11 μsec typ
MCE™ computation data range	16 bit signed
Program RAM loaded from external EEPROM	48K bytes
Data RAM	8K bytes
GateKill latency (digital filtered)	2 μsec
PWM carrier frequency	14 bits/ SYSCLK
A/D input channels	8
A/D converter resolution	12 bits
A/D converter conversion speed	2 μsec
8051 instruction execution speed	2 SYSCLK
Analog output (PWM) resolution	8 bits
UART baud rate (typ)	57.6K bps
Number of I/O (max)	24
Package	QFP64

Description

IRMCF341 is a high performance RAM based motion control IC designed primarily for appliance applications. IRMCF341 is designed to achieve low cost and high performance control solutions for advanced inverterized appliance motor control. IRMCF341 contains two computation engines. One is the Motion Control Engine (MCE™) for sensorless control of permanent magnet motors; the other is an 8-bit high-speed microcontroller (8051). Both computation engines are integrated into one monolithic chip. The MCE™ contains a collection of control elements implemented in hardware such as Proportional plus Integral, Vector rotator, Angle estimator, Multiply/Divide, Low loss SVPWM and Single Shunt IFB. The user can program a motion control algorithm by connecting these control elements using a graphic compiler. Key components of the complex sensorless control algorithms, such as the Angle Estimator, are provided as complete pre-defined control blocks. A unique analog/digital circuit and algorithm to fully support single shunt current reconstruction is also provided. The 8051 microcontroller performs 2-cycle instruction execution (60MIPS at 120MHz). The MCE and 8051 microcontroller are connected via dual port RAM for signal monitoring and command input. An advanced graphic compiler for the MCE™ is seamlessly integrated into the MATLAB/Simulink environment, while third party JTAG-based emulator tools are supported for 8051 software developments. IRMCF341 comes in a small QFP64 pin package.

1 Overview

IRMCF341 is a new International Rectifier integrated circuit device primarily designed as a one-chip solution for complete inverter controlled appliance motor control applications. Unlike a traditional microcontroller or DSP, the IRMCF341 provides a built-in closed loop sensorless control algorithm using the unique Motion Control Engine (MCE™) for permanent magnet motors. The MCE™ consists of a collection of control elements, motion peripherals, a dedicated motion control sequencer and dual port RAM to map internal signal nodes. IRMCF341 also employs a unique single shunt current reconstruction circuit to eliminate additional analog/digital circuitry and enables a direct shunt resistor interface to the IC. Motion control programming is achieved using a dedicated graphical compiler integrated into the MATLAB/Simulink™ development environment. Sequencing, user interface, host communication, and upper layer control tasks can be implemented in the 8051 high-speed 8-bit microcontroller. The 8051 microcontroller is equipped with a JTAG port to facilitate emulation and debugging tools. Figure 1 shows a typical application schematic using the IRMCF341.

IRMCF341 contains 48K bytes of program RAM, which can be loaded from external EEPROM for 8051 program execution. The IRMCF341 is intended for development purposes. For high volume production, the program RAM is replaced with 64K bytes of OTP ROM. Both the development and ROM versions come in a 64-pin QFP package with identical pin configuration to facilitate PC board layout and transition to mass production.

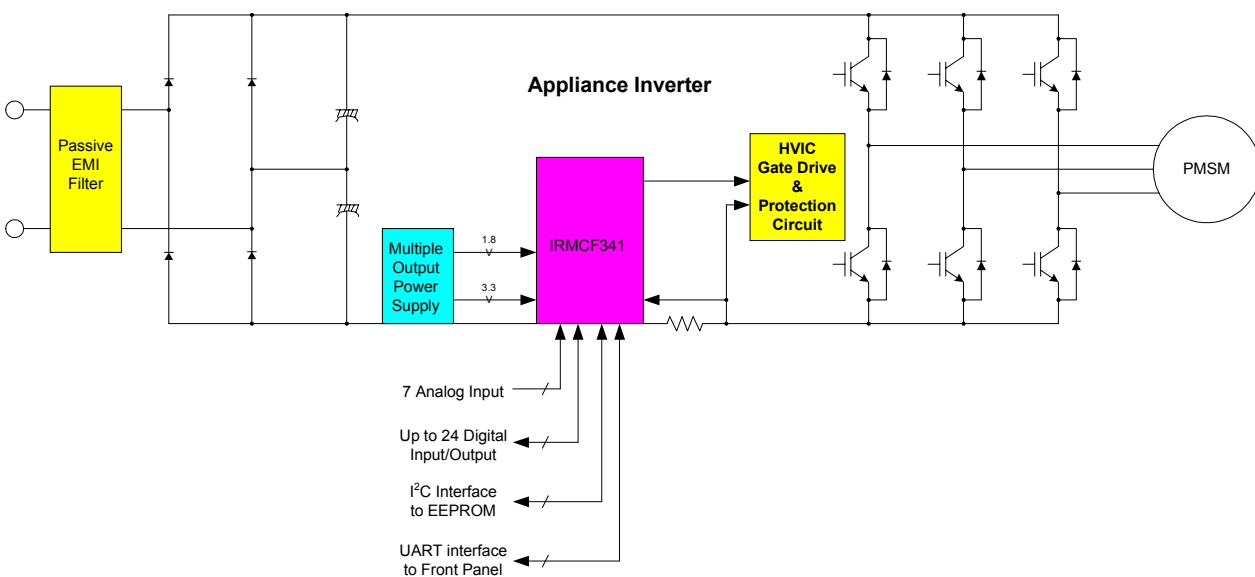

Figure 1. Typical Application Block Diagram Using IRMCF341

2 IRMCF341 Block Diagram and Main Functions

IRMCF341 block diagram is shown in Figure 2.

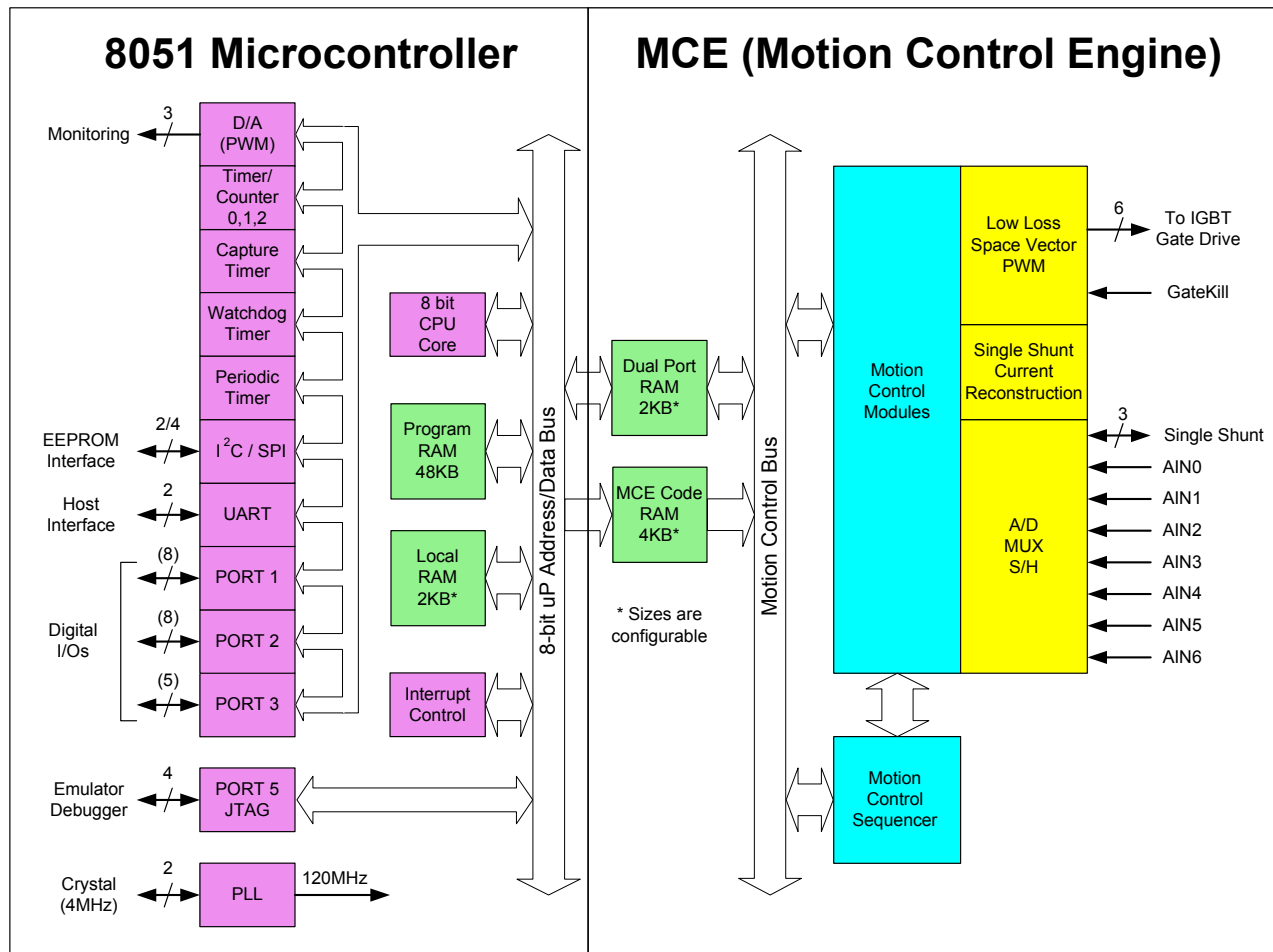

Figure 2. IRMCF341 Internal Block Diagram

IRMCF341 contains the following functions for sensorless AC motor control applications:

- Motion Control Engine (MCE™)
 - Proportional plus Integral block
 - Low pass filter
 - Differentiator and lag (high pass filter)
 - Ramp
 - Limit

- Angle estimate (sensorless control)
- Inverse Clark transformation
- Vector rotator
- Bit latch
- Peak detect
- Transition
- Multiply-divide (signed and unsigned)
- Divide (signed and unsigned)
- Adder
- Subtractor
- Comparator
- Counter
- Accumulator
- Switch
- Shift
- ATAN (arc tangent)
- Function block (any curve fitting, nonlinear function)
- 16 bit wide Logic operations (AND, OR, XOR, NOT, NEGATE)
- MCE™ program memory and dual port RAM (6K byte)
- MCE™ control sequencer
- 8051 microcontroller
 - Three 16 bit timer/counters
 - One 16 bit periodic timer
 - One 16 bit watchdog timer
 - One 16 bit capture timer
 - Up to twenty discrete I/Os
 - Eight-channel 12 bit A/D
 - Buffered (current sensing) one channel (0 – 1.2V input)
 - Unbuffered seven channels (0 – 1.2V input)
 - JTAG port (4 pins)
 - Up to three channels of analog output (8 bit PWM)
 - UART
 - I²C/SPI port
 - 48K byte program RAM loaded from external EEPROM
 - 2K byte data RAM

3 Pinout

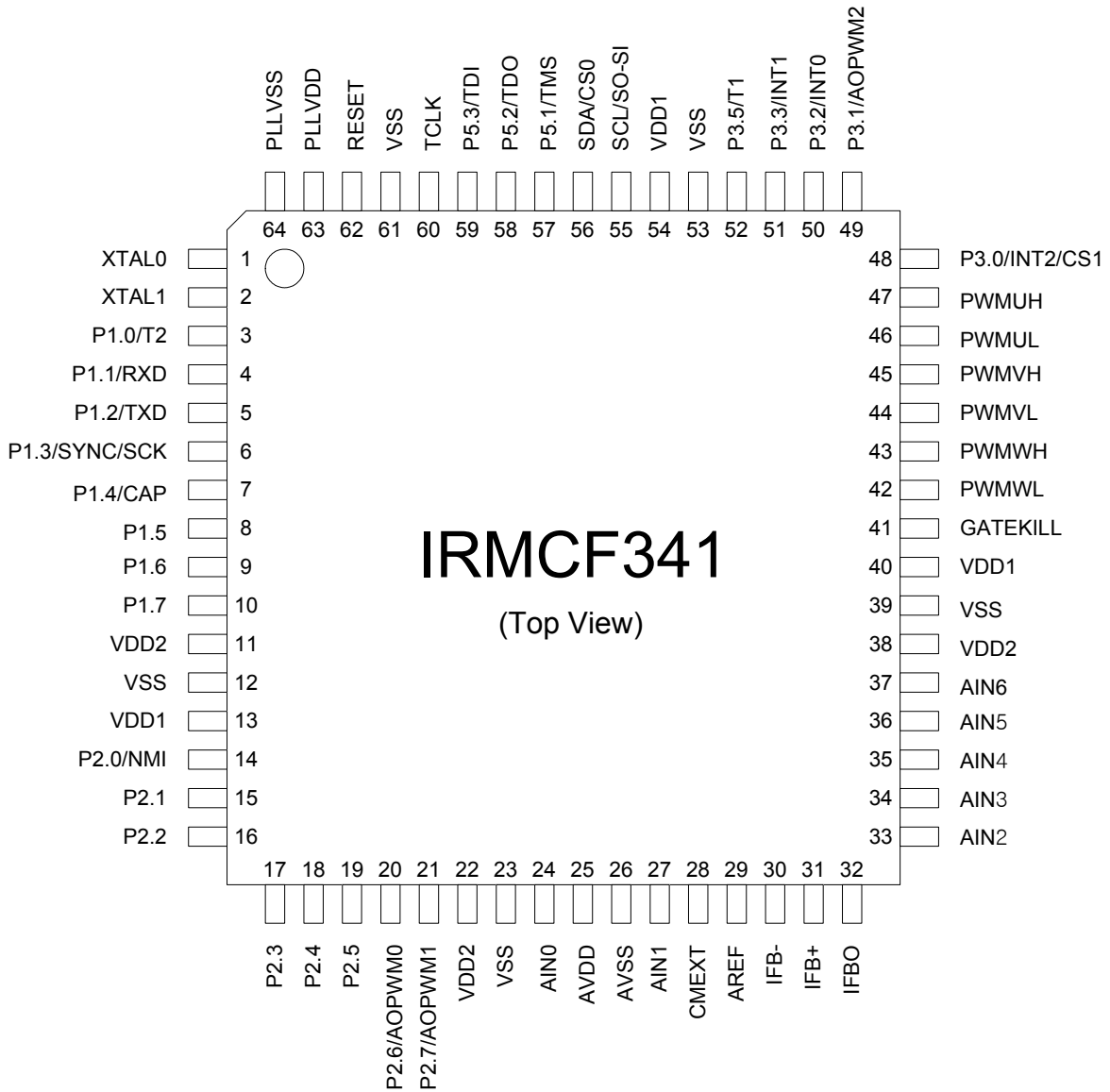

Figure 3. IRMCF341 Pin Configuration

4 Application Connections

Typical application connection is shown in Figure 4. All components necessary to implement a complete sensorless drive control algorithm are shown connected to IRMCF341.

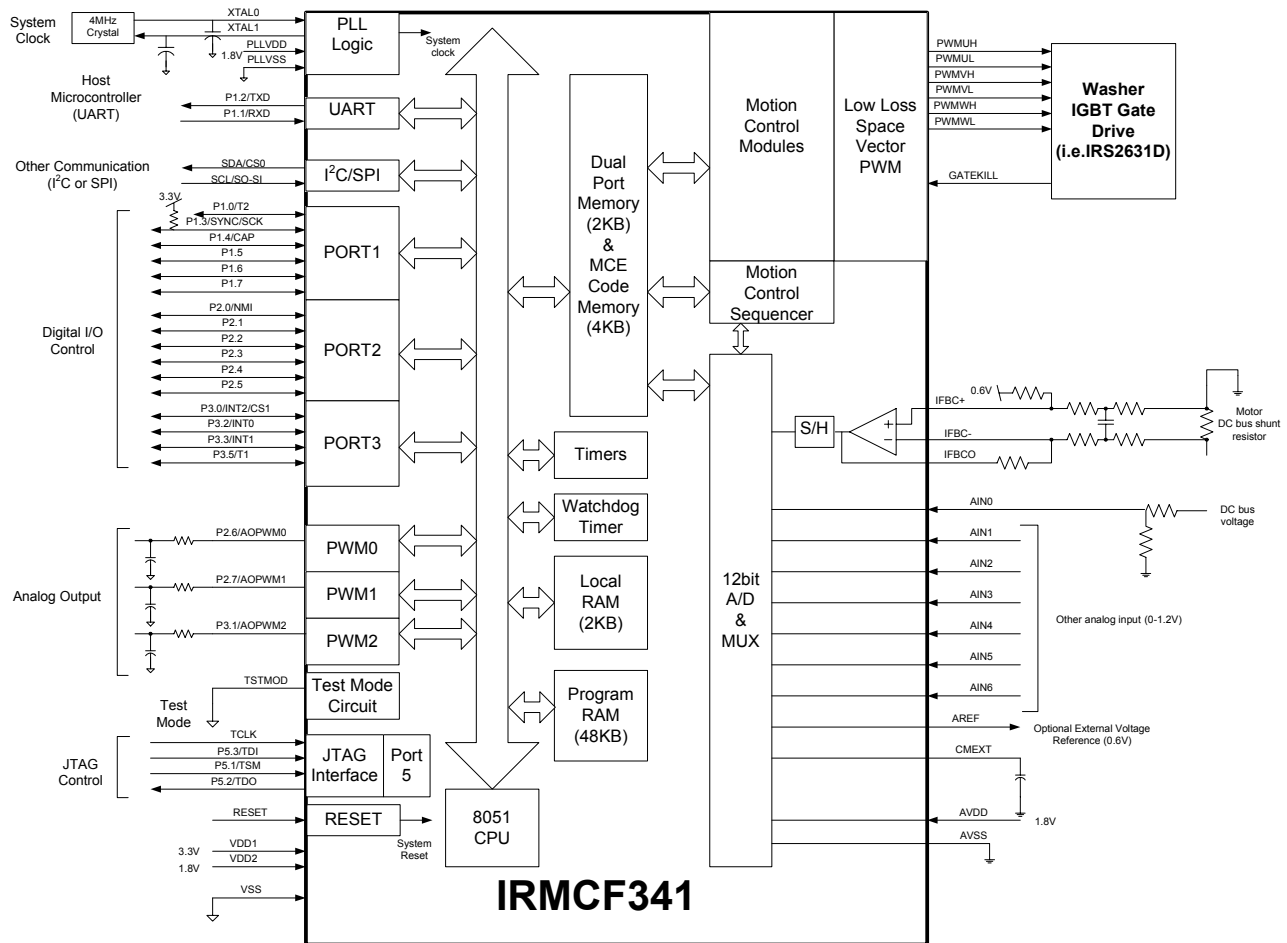
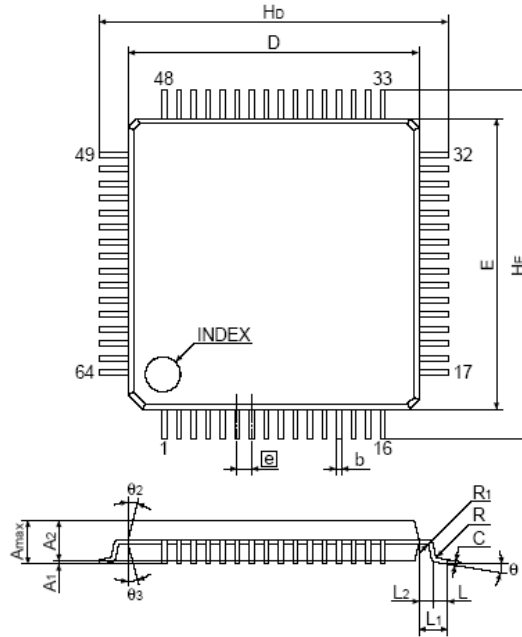

Figure 4. Application Connection of IRMCF341

5 Package Dimensions



Lead type STD (QFP13-64pin STD)						
Symbol	Dimension in Millimeters			Dimension in Inches *		
	Min.	Nom.	Max.	Min.	Nom.	Max.
E	9.9	10	10.1	(0.390)	(0.394)	(0.397)
D	9.9	10	10.1	(0.390)	(0.394)	(0.397)
A			1.7			(0.066)
A ₁		0.1			(0.004)	
A ₂	1.3	1.4	1.5	(0.052)	(0.055)	(0.059)
\overline{e}		0.5			(0.020)	
b	0.13	0.18	0.28	(0.006)	(0.007)	(0.011)
C	0.1	0.125	0.175	(0.004)	(0.005)	(0.006)
θ	0°		10°	(0°)		(10°)
L	0.3	0.5	0.7	(0.012)	(0.020)	(0.027)
L ₁		1			(0.039)	
L ₂		0.5			(0.020)	
H _E	11.6	12	12.4	(0.457)	(0.472)	(0.488)
H _D	11.6	12	12.4	(0.457)	(0.472)	(0.488)
θ_2		12°			(12°)	
θ_3		12°			(12°)	
R		0.2			(0.008)	
R ₁		0.2			(0.008)	

* for reference

Figure 5. Package Drawing

International
IOR Rectifier

IR WORLD HEADQUARTERS: 233 Kansas St., El Segundo, California 90245, Tel: (310) 252-7105
<http://www.irf.com> *Data and specifications subject to change without notice. 5/26/2006*

Sales Offices, Agents and Distributors in Major Cities Throughout the World.