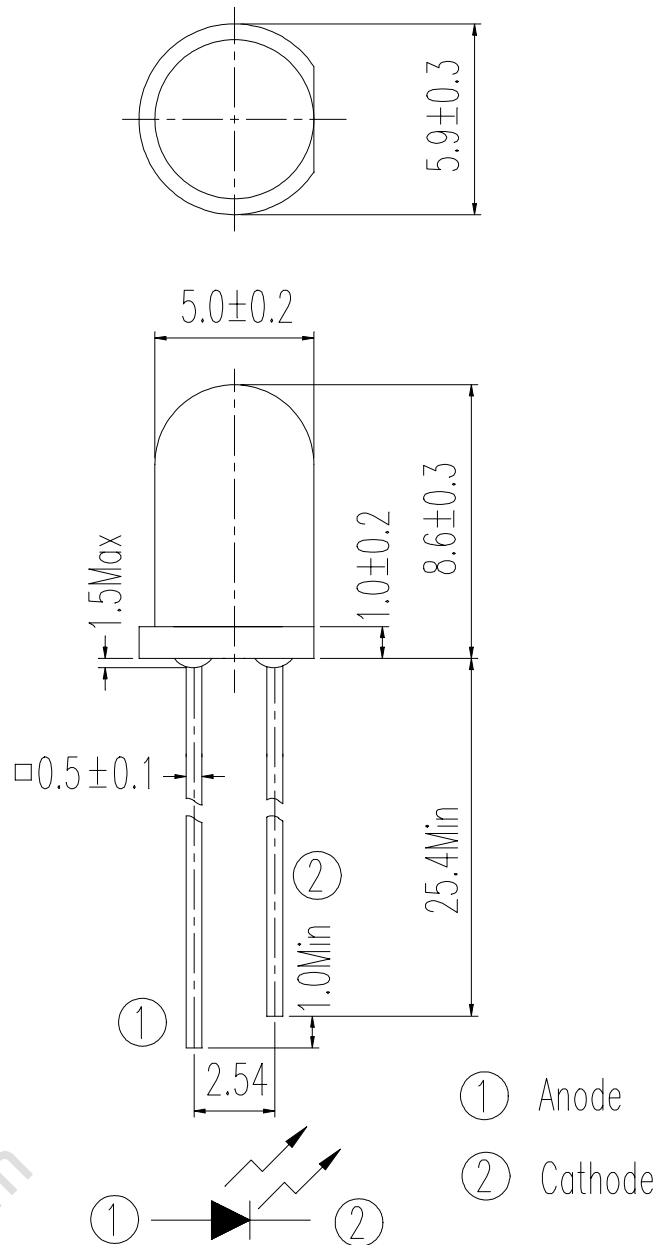

Device Number: DIR-033-103 REV: 1.2
MODEL NO: IR333/L10 ECN: _____ Page: 1/8

Package Dimensions:

DESIGNER	CHECKER	APPROVED

Office: NO 25, Lane 76, Chung Yang Rd., Sec.3
Tucheng, Taipei 236, Taiwan, R.O.C.
TEL: 886-2-2267-2000, 267-9936 (22 Lines)
FAX: 886-2-2267-6189

Device Number: DIR-033-103 REV: 1.2
MODEL NO: IR333/L10 ECN: _____ Page: 2/8

©Notes :

- 1.All dimensions are in millimeters.
- 2.Lead spacing is measured where the lead emerge from the package .
- 3.Protruded resin under flange 1.5 mm Max.
- 4.Lens color : Blue transparent.
- 5.Above specification may be changed without notice. EVERLIGHT will reserve authority on material change for above specification.
- 6.These specification sheets include materials protected under copyright of EVERLIGHT corporation . Please don't reproduce or cause anyone to reproduce them without EVERLIGHT's consent.
- 7.When using this product , please observe the absolute maximum ratings and the instructions for use outlined in these specification sheets. EVERLIGHT assumes no responsibility for any damage resulting from use of the product which does not comply with the absolute maximum ratings and the instructions included in these specification sheets.

Description

EVERLIGHT's infrared emitting diode (IR333/L10) is a high intensity diode, molded in a clear,blue transparent plastic package.

The device is spectrally matched with phototransistor, photodiode and infrared receiver module.

Features

- High radiant intensity
- Peak wavelength $\lambda_p = 940\text{nm}$
- View angle 20°
- High reliability

Applications

- Free air transmission system
- Optoelectronic switch
- Infrared remote control units with high power requirement

Absolute Maximum Ratings

(Ta=25°C)

Parameter	Symbol	Rating	Unit
Continuous Forward Current	I_F	60	mA
Peak Forward Current Pulse width=100 μ s , Duty cycle=1%	I_{FP}	1.0	A
Reverse Voltage	V_R	5	V
Operating Temperature Range	Topr	-40 to+85	°C
Storage Temperature Range	Tstg	-40 to+85	°C
Lead Soldering Temperature (1/16 inch from body for 5 sec.)	Tsol	260	°C
Power Dissipation at (or below) 25°C Free Air Temperature	Pd	160	mW

Electro Optical Characteristics

(Ta=25°C)

Parameter	Symbol	Min	Typ	Max	Unit	Condition
Radiant Intensity	E_e	7.8	20		mW/sr	$I_F=20\text{mA}$
			85			$I_F=100\text{mA}, t_p=100 \mu\text{s}, t_p/T=0.01$
			750			$I_F=1\text{A}, t_p=100 \mu\text{s}, t_p/T=0.01$
Peak Wavelength	λ_p		940		nm	$I_F=20\text{mA}$
Spectral Bandwidth	$\Delta\lambda$		45		nm	$I_F=20\text{mA}$
Forward Voltage	V_F		1.2	1.5	V	$I_F=20\text{mA}$
			1.4	1.85		$I_F=100\text{mA}, t_p=100 \mu\text{s}, t_p/T=0.01$
			2.6	4.0		$I_F=1\text{A}, t_p=100 \mu\text{s}, t_p/T=0.01$
Reverse Current	I_R			10	μA	$V_R=5\text{V}$
View Angle	2 θ 1/2		20		deg	$I_F=20\text{mA}$

To Distinguish Intensity

(Ta=25°C)

CONDITION: $I_F=20\text{mA}$

Unit : mW/sr

Bin Number	M	N	P	Q
Min	7.80	11.00	15.00	21.00
Max	12.50	17.60	24.00	34.00

Typical Electrical/Optical/Characteristics Curves

Fig. 1 Forward Current vs. Ambient Temperature

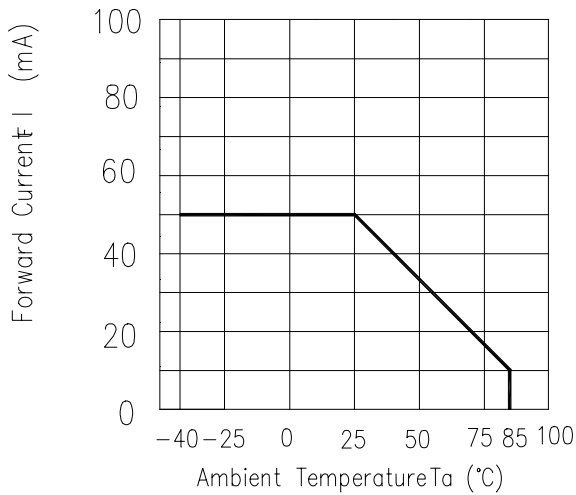

Fig. 2 Spectral Distribution

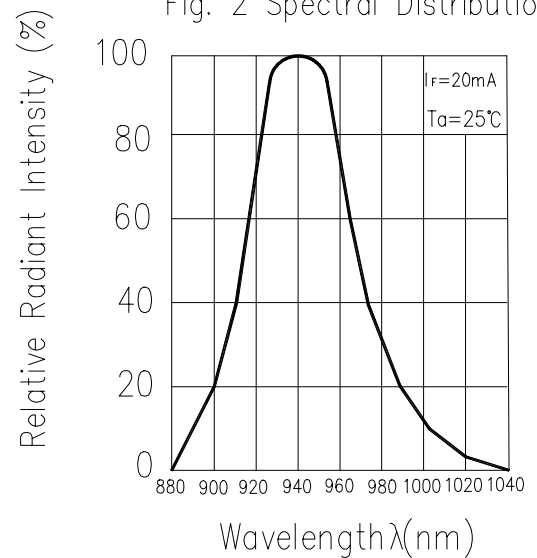

Fig. 3 Peak Emission Wavelength vs. Ambient Temperature

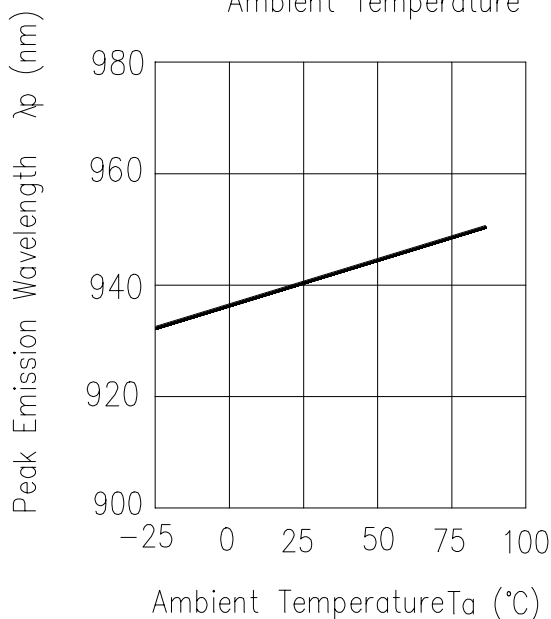
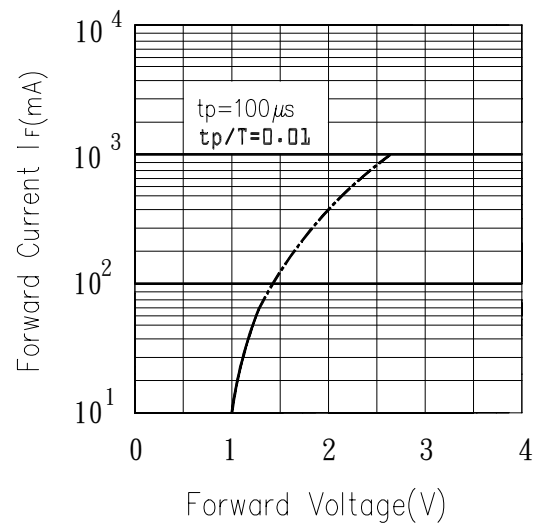
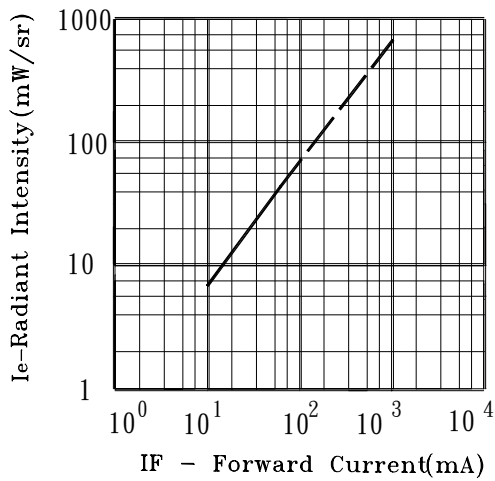
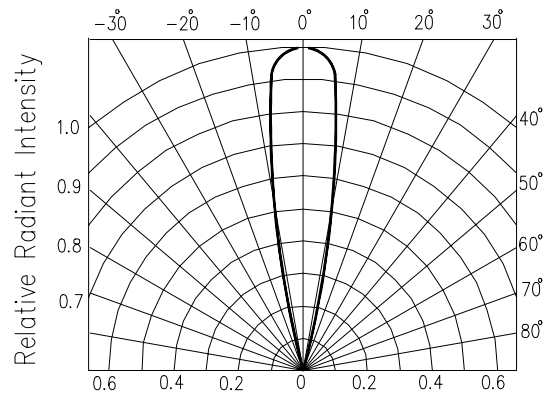
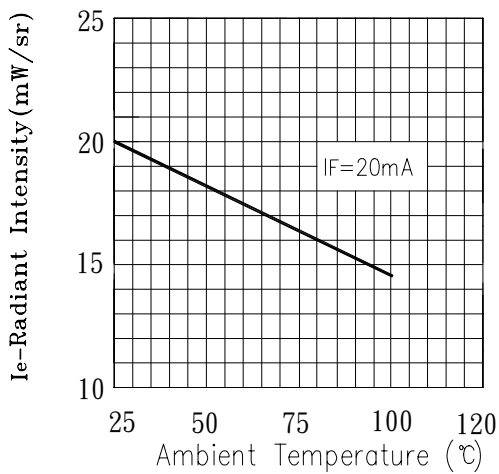
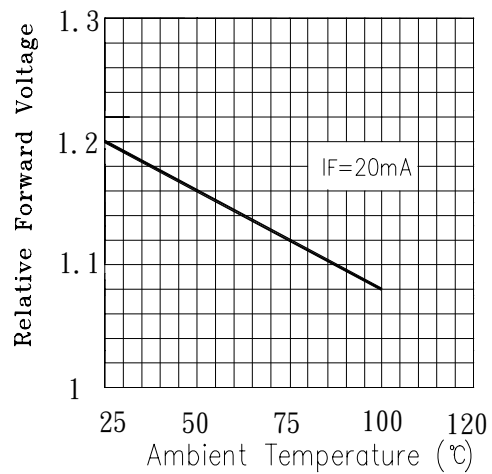

Fig. 4 Forward Current vs. Forward Voltage



Typical Electrical/Optical/Characteristics CurvesFig. 5 Relative Intensity vs.
Forward CurrentFig. 6 Relative Radiant Intensity vs.
Angular DisplacementFig. 7 Relative Intensity vs.
Ambient Temperature (°C)Fig. 8 Forward Current vs.
Ambient Temperature (°C)

Reliability

The reliability of products shall be satisfied with items listed below.

Confidence level : 90%

LTPD : 10%

Test Items	Test Conditions	Failure Judgement Criteria	Samples(n) Defective(c)
Operation life	$I_F=20\text{mA}$, $T_a : 25^\circ\text{C}$ 1000hrs	$I_R \geq U \times 2$ $E_e \leq L \times 0.8$ $V_F \geq U \times 1.2$ U : Upper specification limit L : Lower specification limit	n =22 , c=0
Temperature cycle	1 cycle -55°C to $+25^\circ\text{C}$ to $+85^\circ\text{C}$ (30min) (5min) (30min) 50 cycle test t		n =22 , c=0
Thermal shock	-10°C to $+100^\circ\text{C}$ (5min) (10sec) (5min) 50cycle test		n =22 , c=0
High temperature storage	Temp : $+100^\circ\text{C}$ 1000hrs		n =22 , c=0
Low temperature storage	Temp : -55°C 1000hrs		n =22 , c=0
High temperature High humidity	$T_a : 85^\circ\text{C}$ RH : 85% 1000hrs		n =22 , c=0
Solder heat	Temp : $260 \pm 5^\circ\text{C}$ 5sec 4mm Form the bottom of the package.		n =22 , c=0
Solderability	Temp : $230 \pm 5^\circ\text{C}$ 5sec 4mm Form the bottom of the package.	More than 90% of Lead to be covered by soldering	n =22 , c=0

Test Method For PowerCondition : $I_F=20$ mA

Test Item : Radiant Intensity (mW/sr)

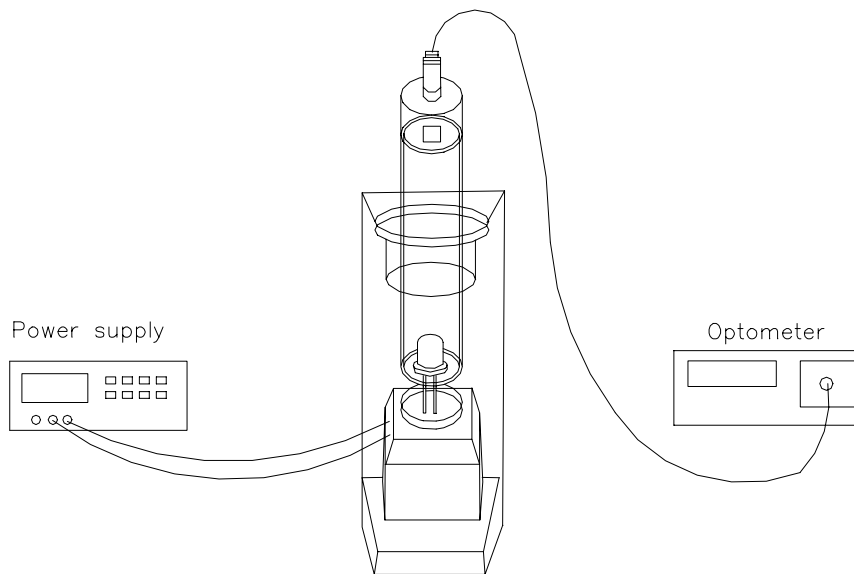
**Supplements**

1.Parts

(1) Chip

Type	Material	Peak Wavelength
IR	GaAlAs	940nm

(2) Material

Type	Lead Frame	Wire	Package
Material	SPCC	Gold	Epoxy

EVERLIGHT

EVERLIGHT ELECTRONICS CO., LTD.

Device Number: DIR-033-103 REV: 1.2MODEL NO: IR333/L10 ECN: _____ Page: 8/8**Packing Specifications**

1. Bag

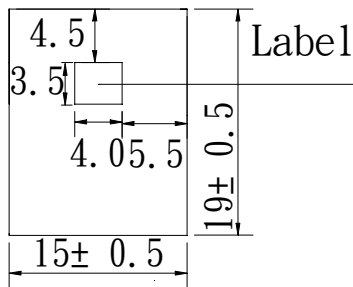

2. Box

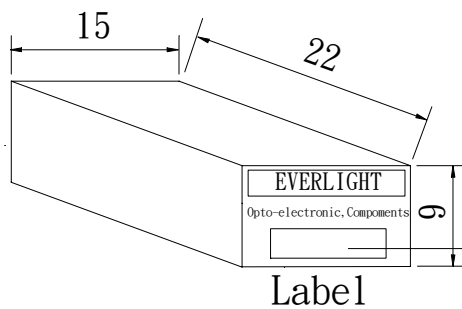
**EVERLIGHT**

CPN:

P/N:

IR333/L10

QTY:

LOT NO:

CAT:

HUE:

REF:

3. Carton

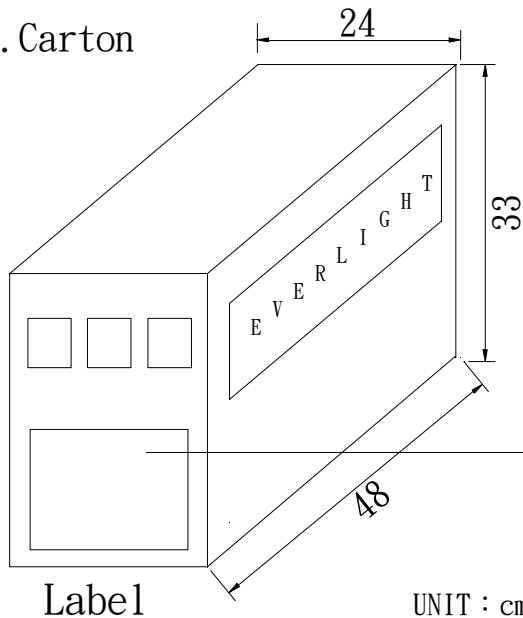

MADE IN TAIWAN

CPN : Customer's Production Number

P/N : Production Number

QTY : Packing Quantity

CAT : Ranks

HUE : Peak Wavelength

REF : Reference

LOT NO : Lot Number

MADE IN TAIWAN : Production Place

Packing Quantity Specification

1.500Pcs/1Bag , 6Bags/1Box

2.10Boxes/1Carton