

Features

- Integral TTL Driver
- Low DC Power Consumption
- Fast Switching Speed: 7 ns Typical
- Surface Mount Package
- 50 Ohm Nominal Impedance
- MIL-STD-883 Screening Available

Description

M/A-COM's SW-313 is a GaAs FET SPDT absorptive switch with integral silicon ASIC driver. Packaged in a 16-lead ceramic surface mount package, this device offers excellent performance and repeatability from DC to 3 GHz while maintaining low power consumption. The SW-313 is ideally suited for use where fast speed, low power consumption and broadband applications are required. MIL-STD-883 screening available.

Electrical Specifications^{1,2} (From -55°C to +85°C)

Parameter	Test Conditions	Frequency	Units	Min	Typ	Max
Insertion Loss	—	DC - 3000 MHz	dB	—	—	1.2
		DC - 2000 MHz	dB	—	—	1.1
		DC - 1000 MHz	dB	—	—	0.9
		DC - 500 MHz	dB	—	—	0.8
VSWR	—	DC - 3000 MHz	Ratio	—	—	1.4:1
		DC - 2000 MHz	Ratio	—	—	1.35:1
		DC - 1000 MHz	Ratio	—	—	1.35:1
		DC - 500 MHz	Ratio	—	—	1.3:1
Isolation	—	DC - 3000 MHz	dB	35	—	—
		DC - 2000 MHz	dB	45	—	—
		DC - 1000 MHz	dB	50	—	—
		DC - 500 MHz	dB	55	—	—
Trise, Tfall	10% to 90%	—	ns	—	7	—
Ton, Toff	1.3V CTL to 90% / 10%	—	ns	—	18	—
Transients	In-Band	—	mV	—	25	—
1 dB Compression	Input Power	0.05 GHz	dBm	—	+25	—
		0.5 GHz to 3 GHz	dBm	—	+30	—
IP2	Two-Tone Input Power up to +5 dBm	0.05 GHz	dBm	—	+60	—
		0.5 GHz to 3 GHz	dBm	—	+65	—
IP3	Two-Tone Input Power up to +5 dBm	0.05 GHz	dBm	—	+40	—
		0.5 GHz to 3 GHz	dBm	—	+46	—
Vin Low	0V to 0.8V	—	µA	—	—	1
Vin High	2.0V to 5.0V	—	µA	—	—	1

1. All specifications apply when operated with bias voltages of +5V for Vcc and -5V for Vee.
2. When DC blocks are used, a 10K ohm return to GND is required on the RFC port.

CR-9

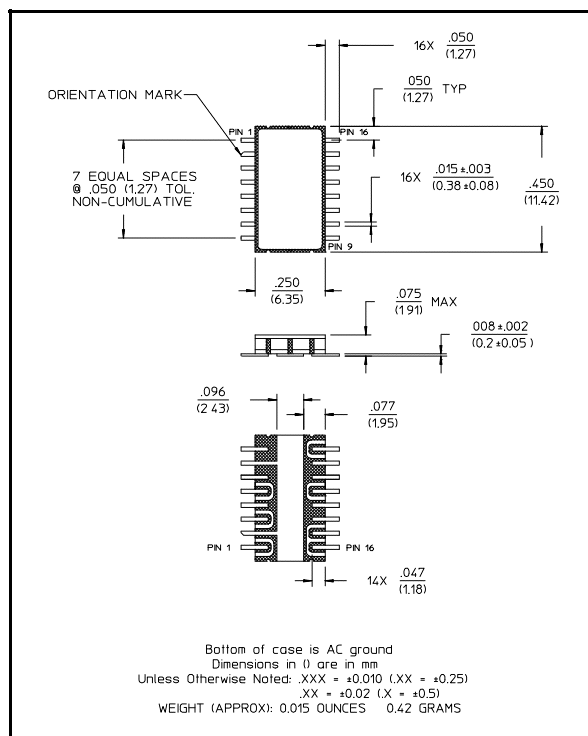

Electrical Specifications (From -55°C to +85°C)

Parameter	Test Conditions	Frequency	Units	Min	Typ	Max
Vcc	+5.0V ± 10%	—	mA	—	—	1
Vee	-5.0V to -8.0V	—	mA	—	—	1

Pin Configuration

Pin No.	Function	Pin No.	Function
1	Vee	9	RFC
2	GND	10	GND
3	GND	11	GND
4	GND	12	RF1
5	RF2	13	GND
6	GND	14	GND
7	GND	15	Vcc
8	GND	16	C1

Pin Configuration (Top View)

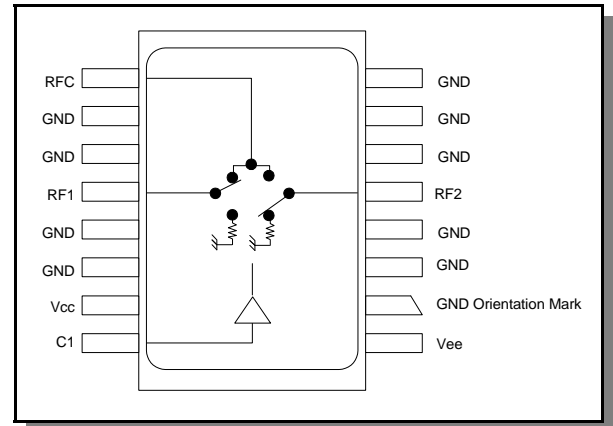

Absolute Maximum Ratings ³

Parameter	Absolute Maximum
Max Input Power 50 MHz 500 - 2000 MHz	+27 dBm +34 dBm
Supply Voltages Vcc Vee	+5.5V -8.5V
Control Voltage ⁴	-0.5V, to Vcc +0.5V
Operating Temperature	-55°C to +125°C
Storage Temperature	-65°C to +150°C

Truth Table

Control Input	Condition of Switch	
	RF Common to Each RF Port	
C1	RF1	RF2
LO	On	Off
HIGH	Off	On

- 3. Operation of this device above any one of these parameters may cause permanent damage.
- 4. Standard CMOS TTL interface, latch-up will occur if logic signal is applied prior to power supply.

Specifications subject to change without notice.

■ North America: Tel. (800) 366-2266
 ■ Asia/Pacific: Tel.+81-44-844-8296, Fax +81-44-844-8298
 ■ Europe: Tel. +44 (1344) 869 595, Fax+44 (1344) 300 020

Visit www.macom.com for additional data sheets and product information.

Typical Performance Curves

Insertion Loss vs. Frequency

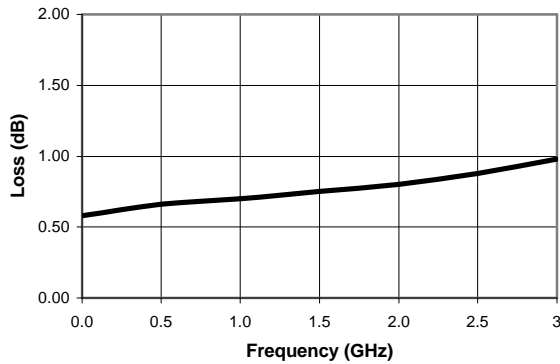

Isolation vs. Frequency

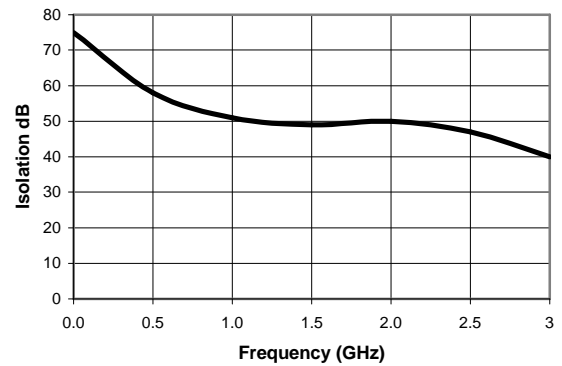

VSWR vs. Frequency

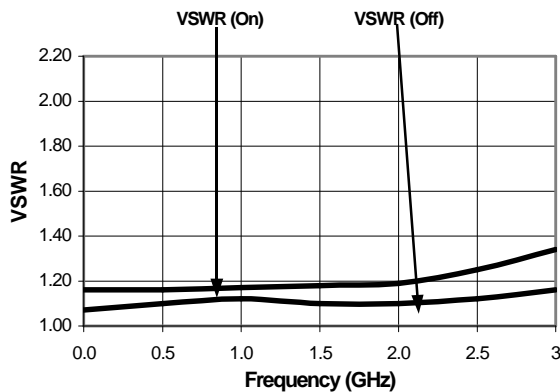

Ordering Information

Part Number	Package
SW-313	CR-9

Specifications subject to change without notice.

- North America: Tel. (800) 366-2266
- Asia/Pacific: Tel.+81-44-844-8296, Fax +81-44-844-8298
- Europe: Tel. +44 (1344) 869 595, Fax+44 (1344) 300 020

Visit www.macom.com for additional data sheets and product information.