

BURN-IN CIRCUITS

1

HA-909

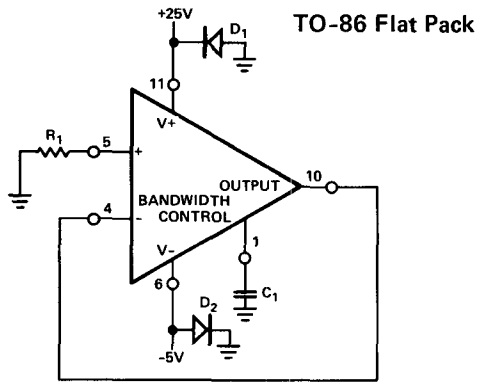

NOTES:
 $T_A = +125^\circ\text{C}$
 $R_1 = 1\text{ Megohm}$
 $C_1 = 0.01\ \mu\text{F}, 100\text{V}$

2

HA-909, HA-2500, HA-2502, HA-2510, HA-2512, HA-2520, HA-2522, HA-2600, HA-2602, HA-2620, HA-2622, HA-2050, HA-2050A, HA-2060, HA-2060A

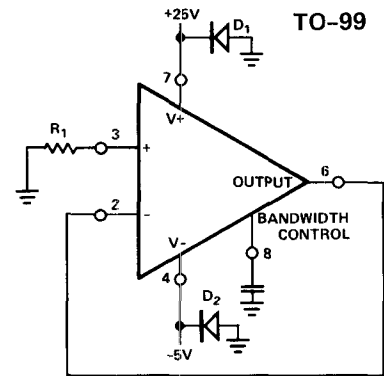

NOTES:
 $T_A = +125^\circ\text{C}$
 $R_1 = 1\text{ Megohm}$
 $C_1 = 0.01\ \mu\text{F}, 100\text{V}$

3

HA-2000

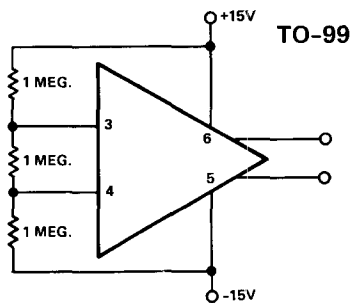

CIRCUIT TYPE:
 FET Front End
 DESIGNATION:
 HA-2000
 OPERATING LIFE TEST CONDITION:
 1) TEMPERATURE: $+125^\circ\text{C}$
 2) VOLTAGE: $\pm 15\text{ Volts}$

4

HA-2111

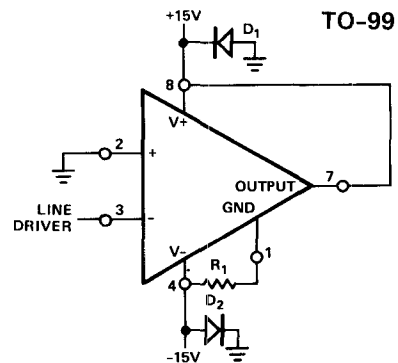

NOTES:
 $T_A = +125^\circ\text{C}$
 $R_1 = 300\ \Omega$
 $D_{1,2} = \text{IN}4002$
 Freq: 50 KHz @ 12V peak to peak

5

HA-2111

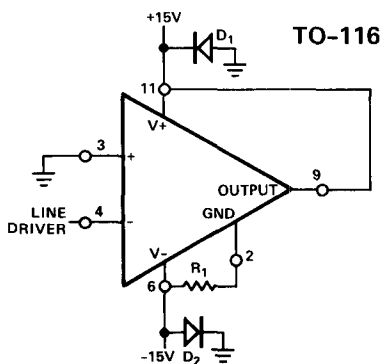

NOTES:
 $T_A = +125^\circ\text{C}$
 $R_1 = 300\ \Omega$
 $D_{1,2} = \text{IN}4002$
 Freq: = 50KHz @ 12V peak to peak

6

HA-2400

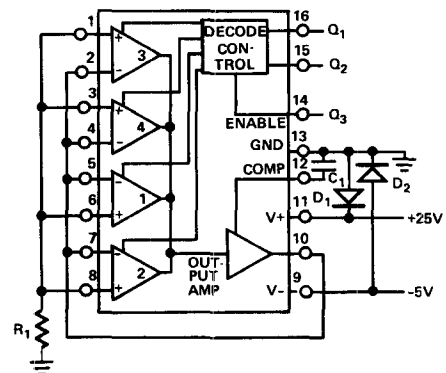

NOTES:
 $T_A = +125^\circ\text{C}$
 $R_1 = 100\text{K}\ \Omega$
 $C_1 = 910\text{pF}, 50\text{V}$
 $D_{1,2} = \text{IN}4002$
 Freq: $Q_1 = 100\text{KHz}; Q_2 = 50\text{KHz}; Q_3 = 25\text{KHz}$

HARRIS OPERATIONAL AMPLIFIERS

Selection Guide for Military Applications

PARAMETER†	-55°C to +125°C												UNITS	
	HA-909	F.E.T. PREAMP		HA-2050	HA-2050A	HA-2060	HA-2060A	PRAM™	S/H	HA-2500	HA-2502	HA-2510		HA-2512
		HA-2000	HA-2000A					HA-2400	HA-2420					
INPUT CHARACTERISTICS														
Offset Voltage	6	25	12	30	17	30	15	7	6	8	10	11	14	mV
Drift (Typ.)	10	50	20	50	20	50	20	20	5	20	20	20	25	μV/°C
Bias Current	300 (1)	10	10	10	10	10	10	400	400	400	500	400	500	nA
Offset Current	300	5	5	5	5	5	5	100	100	50	100	50	100	nA
Common Mode Range	±12	±10	±10	±10	±10	±10	±10	±10	±10	±10	±10	±10	±10	V
INPUT NOISE (1)	5													μVRMS
TRANSFER CHARACTERISTICS														
Large Signal Voltage Gain	25K	.98	.98	5K	5K	60K	60K	25K	25K	15K	10K	7.5K	5K	V/V
Common Mode Rejection Ratio	80	80	80	74	74	74	74	80	80	80	74	80	74	dB
Bandwidth (Typ.) (1)	7	10	10	20(3)	20(3)	24(3)	24(3)	16(3)	2	12	12	12	12	MHz
OUTPUT CHARACTERISTICS														
Output Voltage Swing	±12	±10	±10	±10	±10	±10	±10	±10	±10	±10	±10	±10	±10	V
Output Current (1)	±20	+5(1)	+5(1)	±10(1)	±10(1)	±10(1)	±10(1)	±20(1)	±10	±10	±10	±10	±10	mA
Full Power Bandwidth (Typ.) (1)	25	1,000(3)	1,000(3)	2,000(3)	2,000(3)	600(3)	600(3)	500(3)	70	500	500	1,000	1,000	kHz
TRANSIENT RESPONSE														
Rise Time (1)	75	50(3)	50(3)	50(3)	50(3)	50(3)	50(3)	20(3)	100(3)	50	50	50	50	ns
Overshoot (1)	40	5(3)	5(3)	25(3)	25(3)	25(3)	25(3)	25(3)	20(3)	40	50	40	50	%
Slew Rate (1)	±1.2	100(3)	100(3)	120(3)	120(3)	35(3)	35(3)	50(3)	5(3)	±25	±20	±50	±40	V/μs
Settling Time (Typ.) (1)	(2)	(3) 0.4	(3) 0.4	(3) 0.4	(3) 0.4	(3) 0.8	(3) 0.8	(3) 1.5		0.33	0.33	0.25	0.25	μs
POWER SUPPLY CHARACTERISTICS														
Supply Current (1)	2.5	(1) 1.7	(1) 1.7	(1) 8.0	(1) 8.0	(1) 6.0	(1) 6.0	(1) 6.0	5.0	6.0	6.0	6.0	6.0	mA
Power Supply Rejection Ratio	80	80	80	74	74	74	74	80	80	80	74	80	74	dB
FUNCTIONAL CHARACTERISTICS														
Offset Adjust	Yes*	Yes	Yes	Yes	Yes	Yes	Yes	No	Yes	Yes	Yes	Yes	Yes	
Compensation Components	0	0	0	0AV>3	0AV>3	0AV>5	0AV>5	0AV>10	0	0	0	0	0	
Output Protection	No	No	No	No	No	Yes	Yes	Yes	Yes	No	No	No	No	

PARAMETER†	-55°C to +125°C												UNITS	
	HA-2520	HA-2522	HA-2530	HA-2600	HA-2602	HA-2620	HA-2622	HA-2630	HA-2640	HA-2650	HA-2700	HA-2720		HA-2730
INPUT CHARACTERISTICS														
Offset Voltage	11	14	3	6	7	6	7	±300	6	±5	5	(5)	(5)	.06
Drift (Typ.)	20	25	5	5	5	5	5	(2)	15	8	5	8 to 10	8 to 10	.3
Bias Current	400	500	100	30	60	35	60	200	50	200	50	10 to 40	10 to 40	1
Offset Current	50	100	20	30	60	35	60	(2)	35	60	30	7.5 to 20	7.5 to 20	.5
Common Mode Range	±10	±10	±.5	±11	±11	±11	11	±10	±35(4)	±13	±11	±10	±10	±10
INPUT NOISE (1)												(5)	(5)	μVRMS
TRANSFER CHARACTERISTICS														
Large Signal Voltage Gain	7.5K	5K	100K	70K	60K	70K	60K	.85	75K	20K	100K	25K	25K	10 ⁶
Common Mode Rejection Ratio	80	74	86	80	74	80	74	(2)	80	80	86	80	80	120
Bandwidth (Typ.) (1)	25	25	20	12	12	35	35	8	4	8	1	.01 to 10	.01 to 10	3
OUTPUT CHARACTERISTICS														
Output Voltage Swing	±10	±10	±10	±10	±10	±10	±10	±10	±35(4)	±13	±11	±13.5(3)	±13.5(3)	±10
Output Current (1)	±10	±10	±25	±15	±10	±10	±10	±400	±12	20(3)	±22(3)	±.5 to 5.0(3)	±.5 to 5.0(3)	±10
Full Power Bandwidth (Typ.) (1)	1,500	1,500	5,000	75	75	600	600	8,000	23	30	50	1.5 to 80(3)	1.5 to 80(3)	40
TRANSIENT RESPONSE														
Rise Time (1)	50	50	40	60	60	45	45	30(3)	60(3)	40(3)	(2)	200 to 2,000(3)	200 to 2,000(3)	200(3)
Overshoot (1)	40	50	45	40	40	(2)	(2)	25(3)	15(3)	15(3)	(2)	5 to 15(3)	5 to 15(3)	20(3)
Slew Rate (1)	±100	±80	±280	±4	±4	±25	±20	200	5(3)	±2	±10	.1 to .8(3)	.1 to .8(3)	2.5(3)
Settling Time (Typ.) (1)	0.20	0.20	.5	1.5	1.5	0.30	0.30	.5(3)	1.5(3)	1.5(3)	5.0	(2)	(2)	(2)
POWER SUPPLY CHARACTERISTICS														
Supply Current (1)	6.0	6.0	6	3.7	4.0	3.7	4.0	20	3.8	3	0.15	(5)	(5)	
Power Supply Rejection Ratio	80	74	86	80	74	80	74	66	80	80	86	.02 to .2	.02 to .2	5
FUNCTIONAL CHARACTERISTICS														
Offset Adjust	Yes	Yes	No	Yes	Yes	Yes	Yes	No	Yes	Dip Pkg. Only	Yes	Yes	Yes	No
Compensation Components	0AV>3	0AV>3	1	0	0	0AV>5	0AV>5	0	0	0	0	0	0	3
Output Protection	No	No	No	Yes	Yes	Yes	Yes	External	Yes	Yes	Yes	Yes	Yes	Yes

- (1) At +25°C (3) Typical (5) Dependent upon I_{set} value
(2) Not applicable or not specified (4) V supply = ±40V

* TO-86 only † Guaranteed for ±15V supplies and applicable temperature range unless otherwise specified

MANUFACTURER	PART NUMBER	HARRIS EQUIVALENT	NOTES
Solitron	CM4016A	HI-201	C2
	μ c4000/4001/4002	HA-2600	C2
	μ c4000C/4001C/4002C	HA-2605	C2
	μ c4250	HA-2720	A2
	μ c4250c	HA-2725	A2
Sprague	μ LS/ μ LN2139	HA-2600/2605	B2
	μ LS/ μ LN2151	HA-2600/2605	B2
	μ LS/ μ LN2156	HA-2600/2605	B2
	μ LS/ μ LN2157	HA-2650/2655	B2
	μ LS/ μ LN2158	HA-2620/2625	B2
	μ LS/ μ LN2171	HA-2600/2605	B2
	μ LS/ μ LN2172	HA-2620/2625	B2
	μ LS/ μ LN2173	HA-2600/2605	B2
	μ LS/ μ LN2174	HA-2620/2625	B2
	μ LS/ μ LN2175	HA-2600/2605	B2
	μ LS/ μ LN2176	HA-2620/2625	B2
	μ LS/ μ LN2177	HA-2060/2065	B2
	μ LS/ μ LN2178	HA-2060/2065	B2
	Teledyne Philbrick	1321	HA-2625
1322		HA-2525	A1
1323		HA-2705	A1
1324		HA-2505	B2
1422		HA-2055/2065	B2
1427		HA-2065	C2
1431		HA-2065A	A1
143101		HA-2060A	A1
Texas Instruments		51/72L022	HA-2730/2735
	52/72088	HA-2904/2905	C2
	52/72310	HA-2500/2505	B2
	52111/72311	HA-2111/2311	A1
	52/72558	HA-2650/2655	A2
	52/72660	HA-2700/2705	B2
	52/72770	HA-2600/2605	B2
	52/72771	HA-2620/2625	B2
	75107A/108A	HD-549	C2
	75109/110	HD-545	C2
	75150	HD-1488	C2
	75152	HD-1489/A	C2
	75154	HD-1489/A	C2
Transitron	TOA7709	HA-2600	B2
	TOA8709	HA-2605	B2
	TOA7809	HA-2060A	B2
	TOA8809	HA-2065A	B2

NOTES: A. Pin-for-pin replacement
 B. Minor pin-out difference (offset adj., compensation, etc.)
 C. Not pin compatible — consult data sheets.

1. Identical electrical specifications
 2. Harris part superior in most parameters
 3. Parameter tradeoffs — consult data sheets

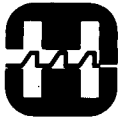

HARRIS
SEMICONDUCTOR
A DIVISION OF HARRIS CORPORATION

HA-2060/2065/ 2060A/2065A

Wide Band F.E.T. Input Operational Amplifier

LINEAR

FEATURES

- GAIN BANDWIDTH PRODUCT 100 MHz
- HIGH INPUT IMPEDANCE 10^{12} OHMS
- LOW BIAS CURRENT 1 pA
- HIGH SLEW RATE $35V/\mu s$
- WIDE POWER BANDWIDTH 600 kHz
- TRUE OP AMP - CAN BE OPERATED INVERTING OR NON-INVERTING
- MEETS MIL-STD-883 REQUIREMENTS

DESCRIPTION

The HA-2060/2065 is an operational amplifier combining the advantages of very wide bandwidth and high slew rate with ultra-low input current and high input resistance. These devices are ideal for use in sample-and-hold circuits, active filters, wide band amplifiers, high gain amplifiers with superior bandwidth, and wherever very low closed loop gain and phase shift errors are required. The device may be operated inverting or non-inverting; and external compensation is required only when operated at closed loop gains less than five. An internal feedback capacitor is provided to cancel phase shift in the feedback loop due to input capacitance.

The HA-2060 is guaranteed for operation from $-55^{\circ}C$ to $+125^{\circ}C$ and the HA-2065 is guaranteed from $0^{\circ}C$ to $+75^{\circ}C$.

PACKAGE

CODE 2A

Bottom View

T0-99

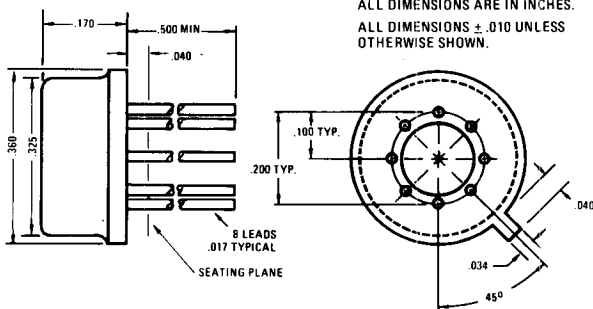

SLEWING WAVEFORM

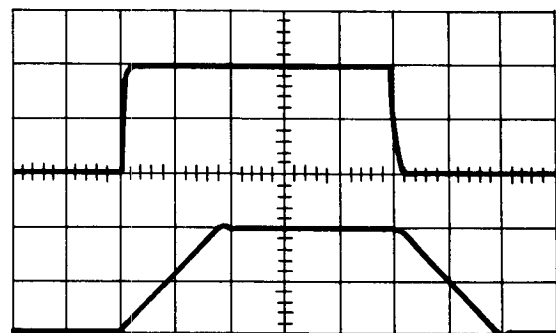

Horizontal Scale: 200ns/Div.
Upper Trace: Input; 1.0V/Div.
Lower Trace: Output; 5.0V/Div.
Gain = +5, $R_L = 2K$ Ohms, $C_L = 50pF$

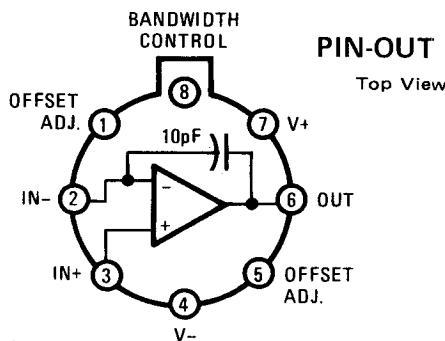

Case Connected to V+

SPECIFICATIONS

ABSOLUTE MAXIMUM RATINGS

Voltage Between V+ and V- Terminals	35.0V	Internal Power Dissipation (Note 10)	300mW	
Differential Input Voltage	±12V	Operating Temp. Range	-55°C ≤ T _A ≤ +125°C	(HA-2060)
Output Current / Full Short Circuit Protection		Storage Temp. Range	0°C ≤ T _A ≤ +75°C	(HA-2065)
			-65°C ≤ T _A ≤ +150°C	

ELECTRICAL CHARACTERISTICS

Test Conditions: V_{Supply} = ±15.0V unless otherwise specified.

PARAMETER	TEMP.	HA-2060/HA-2060A -55°C to +125°C			HA-2065/HA-2065A 0°C to +75°C			UNITS
		LIMITS			LIMITS			
		MIN.	TYP.	MAX.	MIN.	TYP.	MAX.	
INPUT CHARACTERISTICS								
Offset Voltage (Note 1)								
HA-2060 / HA-2065	+25°C		15	25		15	60	mV
	Full			30			65	mV
HA-2060A / HA-2065A	+25°C		7	12		7	12	mV
	Full			15			15	mV
Bias Current	+25°C		1	20		1	20	ρA
	Full		0.5	10		0.02	1	nA
Offset Current	+25°C		0.5	20		0.5	20	ρA
	Full		0.1	5		.005	.5	nA
Input Resistance	+25°C		10 ¹²			10 ¹²		Ω
Input Capacitance	+25°C		5			5		ρF
Common Mode Range	Full	±10.0			±10.0			V
TRANSFER CHARACTERISTICS								
Large Signal Voltage Gain (Note 2, 5)	+25°C	80K	150K		80K	150K		V/V
	Full	60K			70K			V/V
Common Mode Rejection Ratio (Note 3)	Full	74	90		70	90		dB
Gain Bandwidth Product (Note 4)	+25°C		100			100		MHz
OUTPUT CHARACTERISTICS								
Output Voltage Swing (Note 2)	Full	±10	±12		±10	±12		V
Output Current	+25°C	±10	±18		±10	±18		mA
Full Power Bandwidth (Note 5)	+25°C		600			600		kHz
TRANSIENT RESPONSE (NOTES 2, 8, 9)								
Rise Time (Note 6)	+25°C		50			50		ns
Overshoot (Note 6)	+25°C		25			25		%
Slew Rate (Note 5)	+25°C		35			35		V/μs
POWER SUPPLY CHARACTERISTICS								
Supply Current	+25°C		4.0	6.0		4.0	6.0	mA
Power Supply Rejection Ratio (Note 7)	Full	74	90		70	90		dB

- NOTES: 1. Adjustable to zero with 100K Ω pot between pins 1 and 5; wiper to V+.
2. R_L = 2K
3. V_{CM} = ±5.0V
4. A_V > 10
5. V_O = ±10V

6. V_O = ±200mV
7. ΔV = ±5.0V
8. C_L = 50 ρF
9. A_V = +5, See transient response test circuits and waveforms, page 4.
10. Derate by 6.6mW/°C above 105°C

PERFORMANCE CURVES

$V_+ = 15\text{VDC}$, $V_- = 15\text{VDC}$, $T_A = 25^\circ\text{C}$ UNLESS OTHERWISE STATED

INPUT BIAS AND OFFSET CURRENT VS. TEMPERATURE

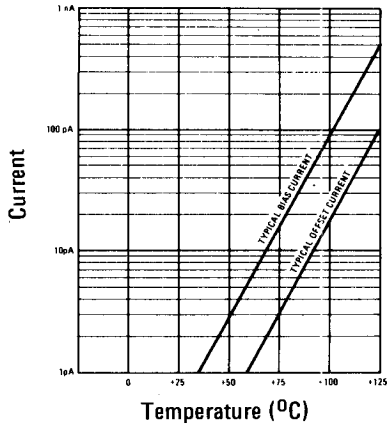

EQUIVALENT INPUT NOISE VS. BANDWIDTH

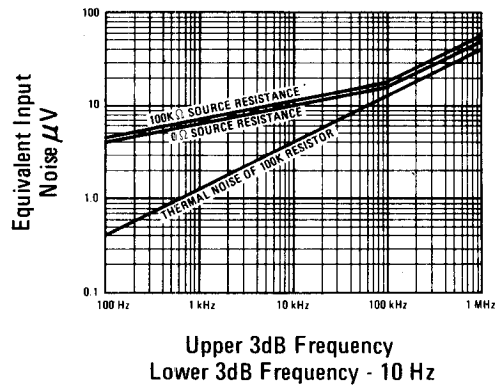

NORMALIZED AC PARAMETERS VS. TEMPERATURE

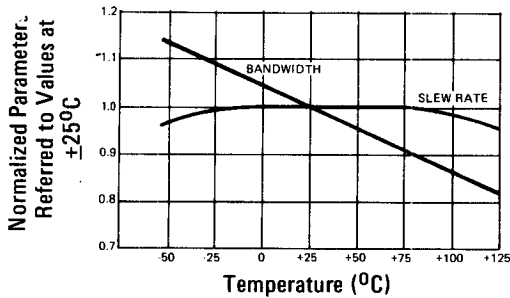

OPEN-LOOP FREQUENCY AND PHASE RESPONSE

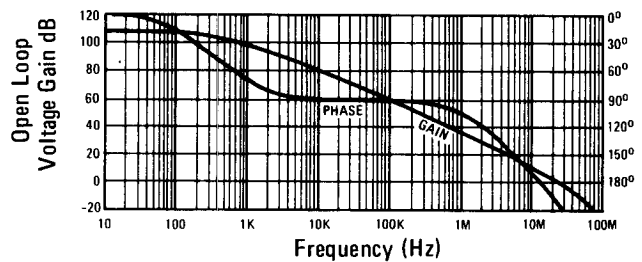

NORMALIZED AC PARAMETERS VS. SUPPLY VOLTAGE AT +25°C

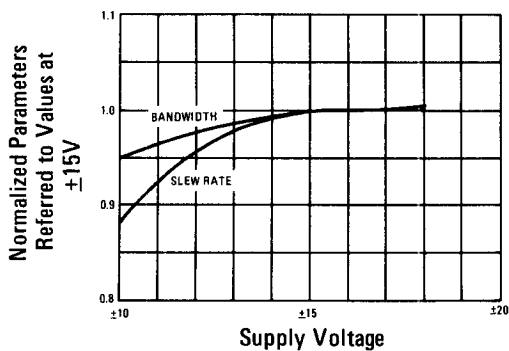

OPEN LOOP FREQUENCY RESPONSE FOR VARIOUS VALUES OF CAPACITORS FROM BANDWIDTH CONTROL PIN TO GROUND

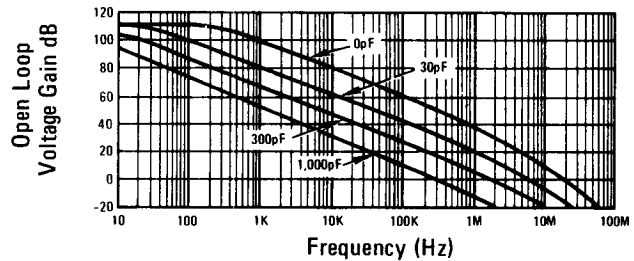

OPEN LOOP VOLTAGE GAIN VS. TEMPERATURE

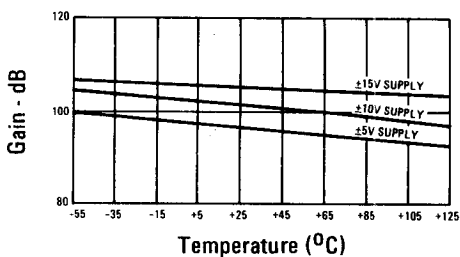

OUTPUT VOLTAGE SWING VS. FREQUENCY AT +25°C

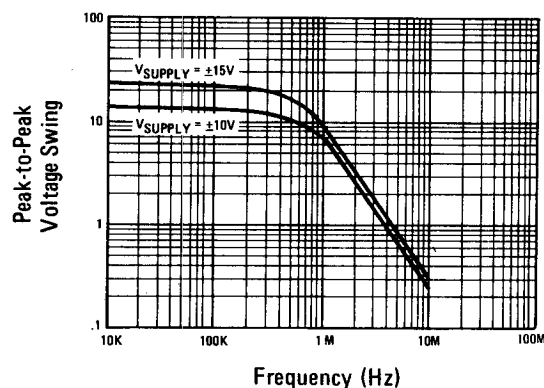

PERFORMANCE CURVES (continued)

POWER SUPPLY CURRENT VS. TEMPERATURE

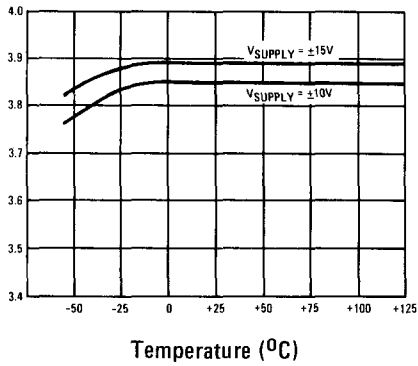

TRANSIENT RESPONSE; $A_V = +5$

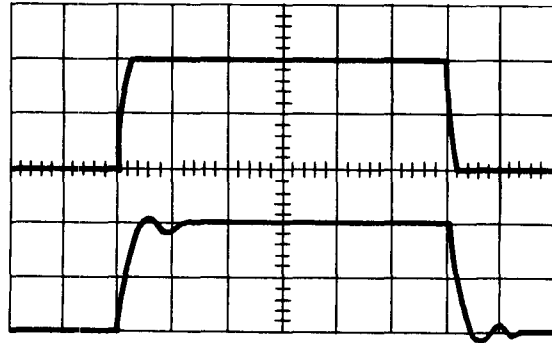

$R_L = 2K \text{ Ohms}, C_L = 50pF$
 Upper Trace: Input; 20mV/Div.
 Lower Trace: Output; 100mV/Div.
 Horizontal = 100ns/Div.
 $T_A = +25^\circ C, V_S = \pm 15V$

SLEW RATE AND SETTLING TIME

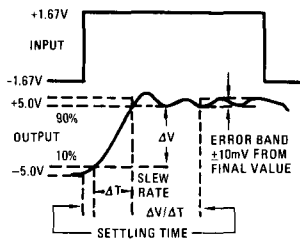

TRANSIENT RESPONSE

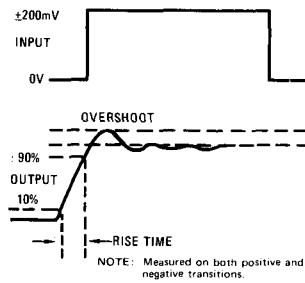

NOTE: Measured on both positive and negative transitions.

SLEW RATE AND TRANSIENT RESPONSE

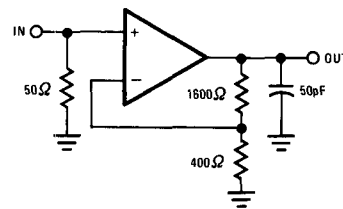

SUGGESTED OFFSET ZERO ADJUST HOOK-UP

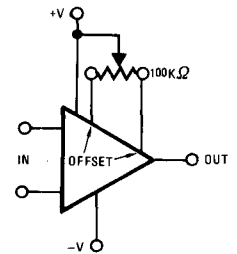

TYPICAL APPLICATIONS

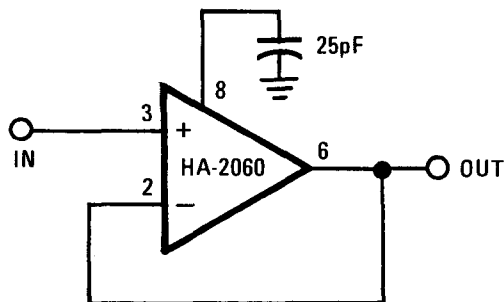

COMPENSATION CIRCUIT FOR UNITY GAIN

SLEW RATE $\approx 5 \text{ V}/\mu s$
 BANDWIDTH $\approx 10 \text{ MHz}$