



厦门华联电子有限公司

Xiamen Hualian Electronics Co., Ltd.

---

# 产品规格书

## SPECIFICATION

---

**产品名称：红色超高亮发光二极管**

**DESCRIPTION: RED SUPER BRIGHT LED**

**型号 MODEL: HFR8053C-30**

电 话：(0592) 6037469

传 真：(0592) 6037471

E-mail : [xmhlec@public.xm.fj.cn](mailto:xmhlec@public.xm.fj.cn)

Website : [www.xmhl.com](http://www.xmhl.com)

地 址：厦门火炬高技术产业开发区华联电子大厦

邮 编：361006

## 1、特点 (FEATURES) :

- 驱动电流低, 发光强度高。 Low Drive Current, High Intensity of Light Emission.
- 快速响应时间, 可用脉冲驱动。 Fast Response Time, Pulse Driven.
- 环氧树脂无色透明封装。 Water Clear Plastic Molding.

## 2、极限参数 (ABSOLUTE MAXIMUM RATINGS) (Ta=25°C):

参数名称 PARAMETER	符号 SYMBOL	额定值 RATING	单位 UNIT
正向脉冲电流(1) Forward Pulse Current	$I_{FPM}$	100	mA
正向电流 Forward Current	$I_{FM}$	50	mA
反向电压 Reverse Voltage	$V_R$	5	V
耗散功率 Power Dissipation	$P_D$	150	mW
工作温度 Operating Temperature	$T_{opr}$	-25 - +80	°C
贮存温度 Storage Temperature	$T_{stg}$	-30 - +100	°C
焊接温度 (5 秒) (2) Soldering Heat (5s)	$T_{sol}$	260	°C

(1) 占空比 Duty: 1/10, 频率 Frequency: 1KHz

(2) 离器件本体 2 mm 以上 Up to 2 mm from the body.

## 3、光电参数 (OPTOELECTRIC CHARACTERISTICS) (Ta=25°C):

参数名称 PARAMETER	符号 SYMBOL	测试条件 TEST CONDITION	最小值 MIN	典型值 TYP	最大值 MAX	单位 UNIT
正向电压 Forward Voltage	$V_F$	$I_F=20mA$	-	2.0	2.5	V
反向电流 Reverse Current	$I_R$	$V_R=5V$	-	-	10	$\mu A$
发光强度 Luminous Intensity	$I_V$	$I_F=20mA$	2500	-	-	mcd
峰值波长 Peak Wave Length	$\lambda_P$	$I_F=20mA$	-	638	-	nm
主波长 Dominate Wave Length	$\lambda_D$	$I_F=20mA$	-	628	-	nm
光谱半宽度 Spectral Line Half Width	$\Delta \lambda$	$I_F=20mA$	-	20	-	nm
半强角度 Viewing Angle	$2\theta_{1/2}$	$I_F=20mA$	-	15	-	°

4、外形尺寸 (DIMENSION)

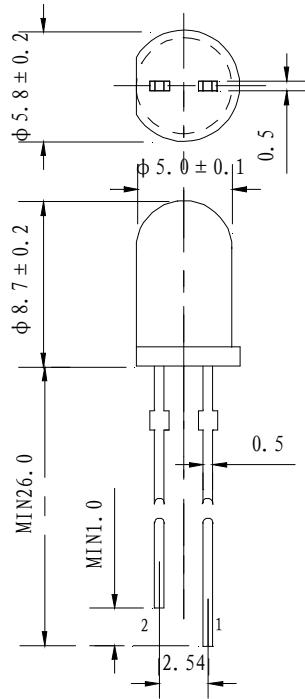

- 1. Anode
- 2. Cathode

- 1. 正极 Anode
- 2. 负极 Cathode

未注公差:  $\pm 0.2\text{mm}$

6. 包装方式 **Packing**

6.1 用 220×110mm<sup>2</sup>防静电塑料袋内包装，500 只/袋。

Internally packed with 220×110mm<sup>2</sup> plastic bag anti-statically, 500pcs/bag.

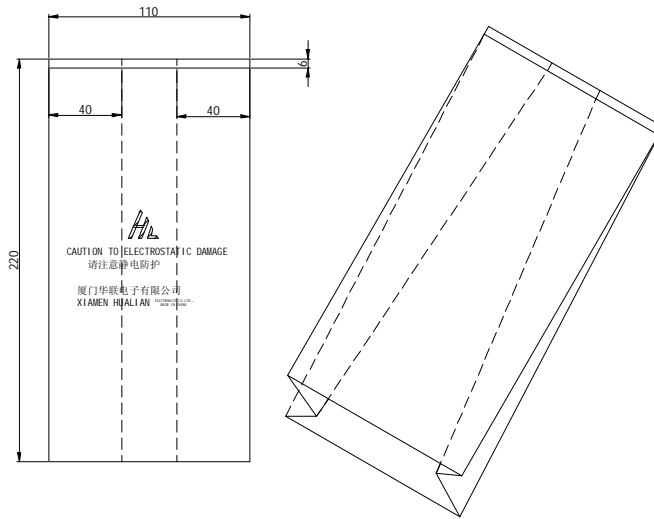

6.2 外包装用纸盒(220×220×190mm)<sup>3</sup>， 10000 只/盒。

Externally Packed with 220×220×190mm<sup>3</sup> cartons, 10000 pcs/carton.

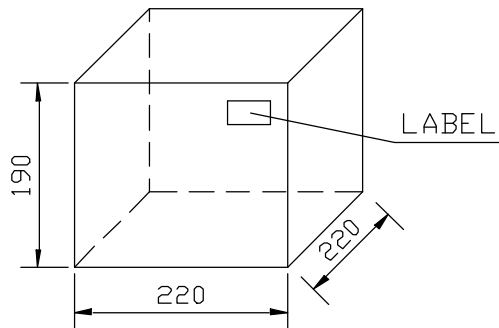

6.3 标识 Label

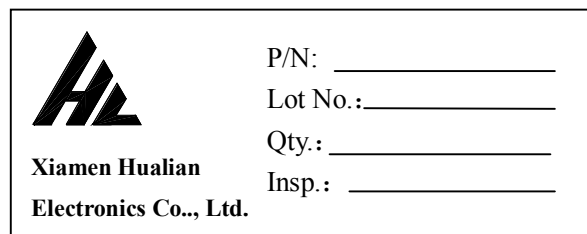

7. 注意事项 **Precautions**

7.1 引线成型 **Forming**

1) 引线成型需在焊接前完成。Leads should be formed before soldering.

- 2) 不能以引线基材为支点成型。Do not form the leads with their bases as a fulcrum.
- 3) 成型位置应离环氧本体 5mm 以上。Forming location should be up to 5mm from the epoxy body.

### 7.2 安装 Installation

LED 安装在 PCB 上，不能造成对引线施加压力。

Installation on PCB do not apply physical stress to the leads when mounting LED lamps on PCB.

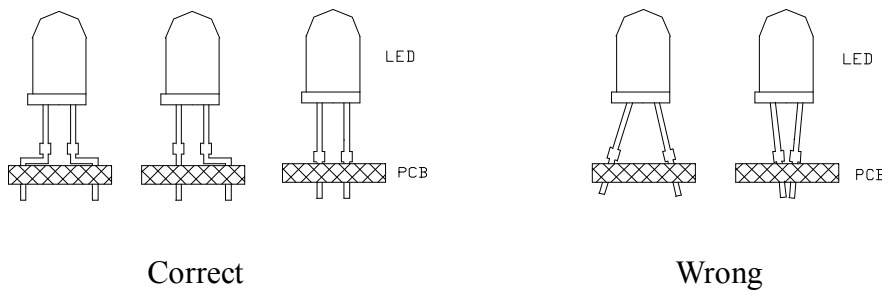

### 7.3 焊接 Soldering

- 1) 环氧不可浸入锡槽内。Do not dip epoxy body into solder bath.
- 2) 加热过程中不能对引线施加压力。Do not apply stress to the leads while they are heated.
- 3) 使用电烙铁焊接时，电烙铁的功率应小于等于 30W，焊接时间应小于 3 秒。

When soldering LED, the solder iron power should be not more than 30W and with the soldering time not more than 3 seconds.

### 9.4 清洗 Cleaning

- 1) 在任何情况下，清洗时间应在常温 1 分钟之内进行。

In any case, the cleaning time should be 1 minute or less at a normal temperature.

- 2) 不可用水清洗，以免腐蚀引线，推荐使用酒精。

Do not clean LEDs with water as the remains may rust the leads. Alcohol is suggested to be used.

- 3) 用超声波清洗 LED 时，超声功率和时间应分别小于 300W 和 30 秒；PCB 和 LED 不能接触振荡器；不能使 PCB 上 LED 产生共振。

When LEDs are ultrasonic-washed, use the ultrasonic output power of less than 300W and the time of less than 30s; do not let the PCB and LEDs touch on the oscillator; do not resonate the LEDs attached on the PCB.

### 7.5 超高亮 LED 为静电敏感器件，所以静电和电涌会损坏 LED。要求使用时佩带防静电腕带，

所有的装置、设备、机器、桌子、地面都必须防静电接地。

The ultra bright LED is an electrostatic insensitive device, so static electricity and surge will damage the LED. It is required to wear a wrist-band when handling the LED. All device, equipment, machinery, desk and ground must be properly grounded.

#### 8. 建议使用方式 **Suggested way of usage.**

LED 使用时必须串联一个保护电阻，正向直流电流为 20mA 左右。

When using LED, it must use a protective resistor in series with DC current about 20 mA.