

CIRCUIT BOARD HARDWARE

SRLCBS Series

Snap Rivet Locking Circuit Board Support



Use Richco Rivet #	For Chassis Thickness
SR-4050	.026 (0.7) - .062 (1.6)
SR-4060	.062 (1.5) - .105 (2.7)
SR-4070	.105 (2.7) - .145 (3.7)
SR-4080	.145 (3.7) - .184 (4.7)
SR-4100	.223 (5.7) - .263 (6.7)

TO SNAP-LOCK IN A .156 ±.003
(4.0 ±0.08) DIA. HOLE, IN A
.062 (1.6) THICK PANEL/BOARD

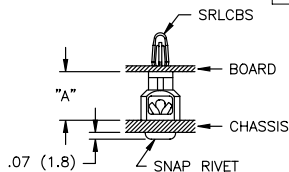
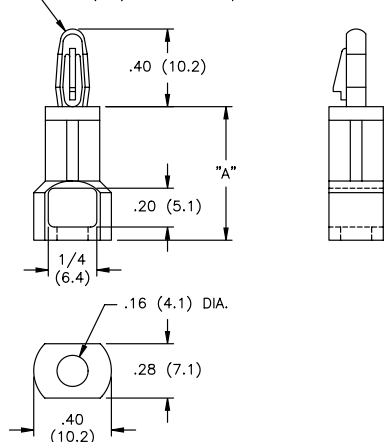

Material: Nylon 6/6, RMS-01
Color: Natural

Part No.	Standard Pack:
	1000 per bag
	"A" ± .015 (0.4)
SRLCBS-6-01	3/8 (9.5)
SRLCBS-7-01	7/16 (11.1)
SRLCBS-8-01	1/2 (12.7)
SRLCBS-10-01	5/8 (15.9)
SRLCBS-12-01	3/4 (19.1)
SRLCBS-14-01	7/8 (22.2)
SRLCBS-16-01	1 (25.4)

Part available in V-0 material by special order. To order, replace -01 with -19.

SRLAHS Series

Snap Rivet Locking Arrowhead Support

Material: Nylon 6/6, RMS-01
Color: Natural

Part No	Standard Pack:
	1000 per bag
	"A" ± .015 (0.4)
SRLAHS-7-01	7/16 (11.1)
SRLAHS-8-01	1/2 (12.7)
SRLAHS-10-01	5/8 (15.9)
SRLAHS-12-01	3/4 (19.1)
SRLAHS-14-01	7/8 (22.2)
SRLAHS-16-01	1 (25.4)

Part available in V-0 material by special order. To order, replace -01 with -19.

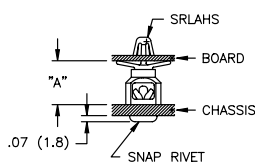
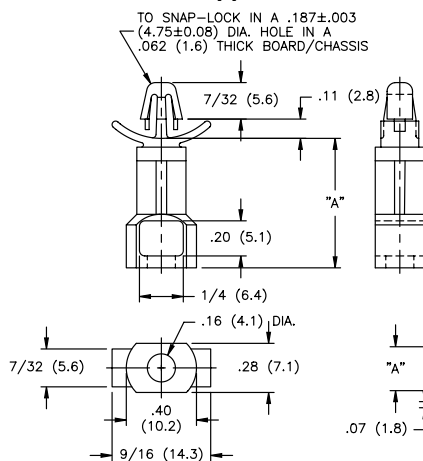

SRSCBS Series

Snap Rivet Studded Circuit Board Support

Material: Nylon 6/6, RMS-01
Color: Natural

Part No.	Standard Pack:
	1000 per bag
	"A" ± .015 (0.4)
SRSCBS-6-01	3/8 (9.5)
SRSCBS-7-01	7/16 (11.1)
SRSCBS-8-01	1/2 (12.7)
SRSCBS-10-01	5/8 (15.9)
SRSCBS-12-01	3/4 (19.1)
SRSCBS-14-01	7/8 (22.2)
SRSCBS-16-01	1 (25.4)

Part available in V-0 material by special order. To order, replace -01 with -19.

Part available with an M-3 or M-4 thread by special order. To order use part number SRSCBS-M3-XX-01 for M-3 thread. Use part number SRSCBS-M4-XX-01 for M-4 thread

Mating Nuts	Threads
HN-6-32-01	6-32
HN-M3-79	M3
HN-M4-01	M4

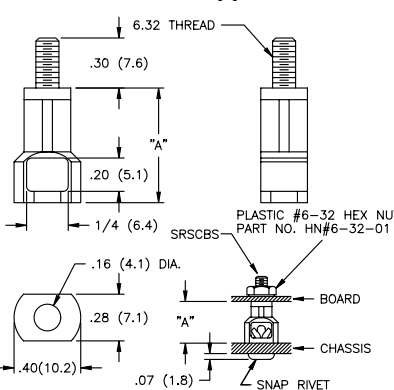

LCBS-L Series

Locking Circuit Board Support, L-Style

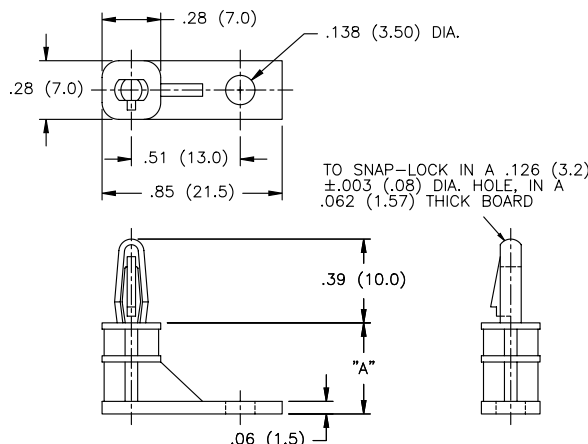

Material: Nylon 6/6, RMS-01
Color: Natural

Part Number	Standard Pack:
	1,000 per bag
	"A" ± .015 (0.4)
LCBS-L-5-01	0.3 (7.6)
LCBS-L-6-01	3/8 (9.5)
LCBS-L-7-01	7/16 (11.1)
LCBS-L-8-01	1/2 (12.7)
LCBS-L-9-01	9/16 (14.3)
LCBS-L-10-01	5/8 (15.9)

Installs with a #4 (M-3) Screw or Rivet

Part available in V-0 material by special order. To order, replace -01 with -19.