



# 12N60

**Power MOSFET**

## 12 Amps, 600/650 Volts N-CHANNEL MOSFET

■ **DESCRIPTION**

The UTC **12N60** are N-Channel enhancement mode power field effect transistors (MOSFET) which are produced using UTC's proprietary, planar stripe, DMOS technology.

These devices are suited for high efficiency switch mode power supply. To minimize on-state resistance, provide superior switching performance, and withstand high energy pulse in the avalanche and commutation mode the advanced technology has been especially tailored.

■ **FEATURES**

- \*  $R_{DS(ON)} = 0.8\Omega @ V_{GS} = 10V$
- \* Ultra low gate charge ( typical 42 nC )
- \* Low reverse transfer capacitance (  $C_{RSS} =$  typical 25 pF )
- \* Fast switching capability
- \* Avalanche energy specified
- \* Improved dv/dt capability, high ruggedness

■ **SYMBOL**

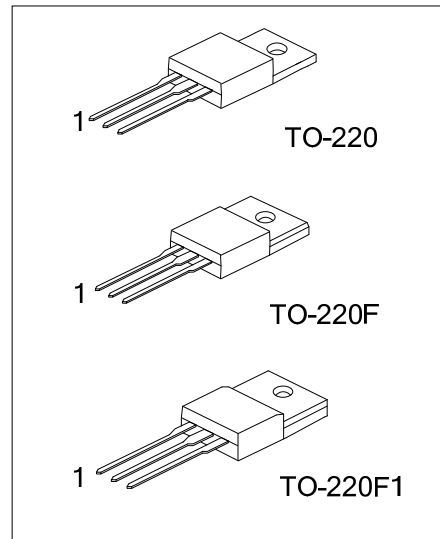
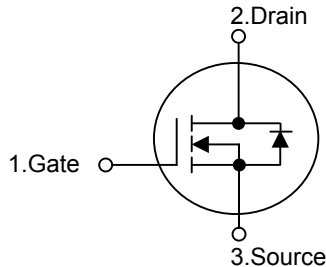

Lead-free: 12N60L  
Halogen-free: 12N60G

■ **ORDERING INFORMATION**

Ordering Number		Package	Pin Assignment			Packing
Lead Free	Halogen Free		1	2	3	
12N60L-x-TA3-T	12N60G-x-TA3-T	TO-220	G	D	S	Tube
12N60L-x-TF1-T	12N60G-x-TF1-T	TO-220F1	G	D	S	Tube
12N60L-x-TF3-T	12N60G-x-TF3-T	TO-220F	G	D	S	Tube

Note: Pin Assignment: G: Gate D: Drain S: Source

<p>12N60L-x-TA3-T</p>	<p>(1) T: Tube (2) TA3: TO-220, TF1: TO-220F1, TF3: TO-220F (3) A: 600V, B: 650V (4) G: Halogen Free, L: Lead Free</p>
-----------------------	--

■ ABSOLUTE MAXIMUM RATINGS ( $T_C = 25^\circ\text{C}$ , unless otherwise specified)

PARAMETER		SYMBOL	RATINGS	UNIT
Drain-Source Voltage	12N60-A	$V_{DSS}$	600	V
	12N60-B		650	V
Gate-Source Voltage		$V_{GSS}$	$\pm 30$	V
Avalanche Current (Note 2)		$I_{AR}$	12	A
Drain Current	Continuous	$I_D$	12	A
	Pulsed (Note 2)	$I_{DM}$	48	A
Avalanche Energy	Single Pulsed (Note 3)	$E_{AS}$	790	mJ
	Repetitive (Note 2)	$E_{AR}$	24	mJ
Peak Diode Recovery dv/dt (Note 4)		dv/dt	4.5	V/ns
Power Dissipation	TO-220	$P_D$	225	$^\circ\text{C/W}$
	TO-220F/TO-220F1		51	$^\circ\text{C/W}$
Junction Temperature		$T_J$	+150	$^\circ\text{C}$
Operating Temperature		$T_{OPR}$	-55 ~ +150	$^\circ\text{C}$
Storage Temperature		$T_{STG}$	-55 ~ +150	$^\circ\text{C}$

Notes: 1. Absolute maximum ratings are those values beyond which the device could be permanently damaged.

Absolute maximum ratings are stress ratings only and functional device operation is not implied.

2. Repetitive Rating : Pulse width limited by maximum junction temperature

3. L = 10mH,  $I_{AS} = 12\text{A}$ ,  $V_{DD} = 50\text{V}$ ,  $R_G = 25\Omega$ , Starting  $T_J = 25^\circ\text{C}$

$I_{SD} \leq 12\text{A}$ ,  $di/dt \leq 200\text{A/s}$ ,  $V_{DD} \leq BV_{DSS}$  Starting  $T_J = 25^\circ\text{C}$

■ THERMAL DATA

PARAMETER		SYMBOL	RATING	UNIT
Junction to Ambient		$\theta_{JA}$	62.5	$^\circ\text{C/W}$
Junction to Case	TO-220	$\theta_{JC}$	0.56	$^\circ\text{C/W}$
	TO-220F/TO-220F1		2.43	$^\circ\text{C/W}$

■ ELECTRICAL CHARACTERISTICS ( $T_C = 25^\circ\text{C}$ , unless otherwise specified)

PARAMETER		SYMBOL	TEST CONDITIONS	MIN	TYP	MAX	UNIT
<b>OFF CHARACTERISTICS</b>							
Drain-Source Breakdown Voltage	12N60-A	$BV_{DSS}$	$V_{GS} = 0\text{V}$ , $I_D = 250\ \mu\text{A}$	600			V
	12N60-B			650			V
Drain-Source Leakage Current		$I_{DSS}$	$V_{DS} = 600\text{V}$ , $V_{GS} = 0\text{V}$			1	$\mu\text{A}$
Gate-Source Leakage Current		$I_{GSS}$	$V_{GS} = \pm 30\text{V}$ , $V_{DS} = 0\text{V}$			$\pm 100$	nA
Breakdown Voltage Temperature Coefficient		$\Delta BV_{DSS}/\Delta T_J$	$I_D = 250\ \mu\text{A}$ , Referenced to $25^\circ\text{C}$		0.7		$\text{V}/^\circ\text{C}$
<b>ON CHARACTERISTICS</b>							
Gate Threshold Voltage		$V_{GS(TH)}$	$V_{DS} = V_{GS}$ , $I_D = 250\ \mu\text{A}$	2.0		4.0	V
Static Drain-Source On-State Resistance		$R_{DS(ON)}$	$V_{GS} = 10\text{V}$ , $I_D = 6.0\text{A}$		0.55	0.8	$\Omega$
<b>DYNAMIC CHARACTERISTICS</b>							
Input Capacitance		$C_{ISS}$	$V_{DS} = 25\text{V}$ , $V_{GS} = 0\text{V}$ , $f = 1\text{MHz}$		1480	1900	pF
Output Capacitance		$C_{OSS}$			200	270	pF
Reverse Transfer Capacitance		$C_{RSS}$			25	35	pF
<b>SWITCHING CHARACTERISTICS</b>							
Turn-On Delay Time		$t_{D(ON)}$	$V_{DD} = 300\text{V}$ , $I_D = 12\text{A}$ , $R_G = 25\Omega$ (Note 4, 5)		30	70	ns
Turn-On Rise Time		$t_R$			115	240	ns
Turn-Off Delay Time		$t_{D(OFF)}$			95	200	ns
Turn-Off Fall Time		$t_F$			85	180	ns
Total Gate Charge		$Q_G$			42	54	nC
Gate-Source Charge		$Q_{GS}$	$V_{DS} = 480\text{V}$ , $I_D = 12\text{A}$ , $V_{GS} = 10\text{V}$ (Note 4, 5)		8.6		nC
Gate-Drain Charge		$Q_{GD}$			21		nC

■ ELECTRICAL CHARACTERISTICS(Cont.)

PARAMETER	SYMBOL	TEST CONDITIONS	MIN	TYP	MAX	UNIT
<b>SOURCE- DRAIN DIODE RATINGS AND CHARACTERISTICS</b>						
Drain-Source Diode Forward Voltage	$V_{SD}$	$V_{GS} = 0\text{ V}, I_S = 12\text{ A}$			1.4	V
Maximum Continuous Drain-Source Diode Forward Current	$I_S$				12	A
Maximum Pulsed Drain-Source Diode Forward Current	$I_{SM}$				48	A
Reverse Recovery Time	$t_{RR}$	$V_{GS} = 0\text{ V}, I_S = 12\text{ A},$		380		ns
Reverse Recovery Charge	$Q_{RR}$	$di_F/dt = 100\text{ A}/\mu\text{s}$ (Note 4)		3.5		$\mu\text{C}$

Notes: 1. Pulse Test : Pulse width  $\leq 300\mu\text{s}$ , Duty cycle  $\leq 2\%$   
 2. Essentially independent of operating temperature.

■ TEST CIRCUITS AND WAVEFORMS

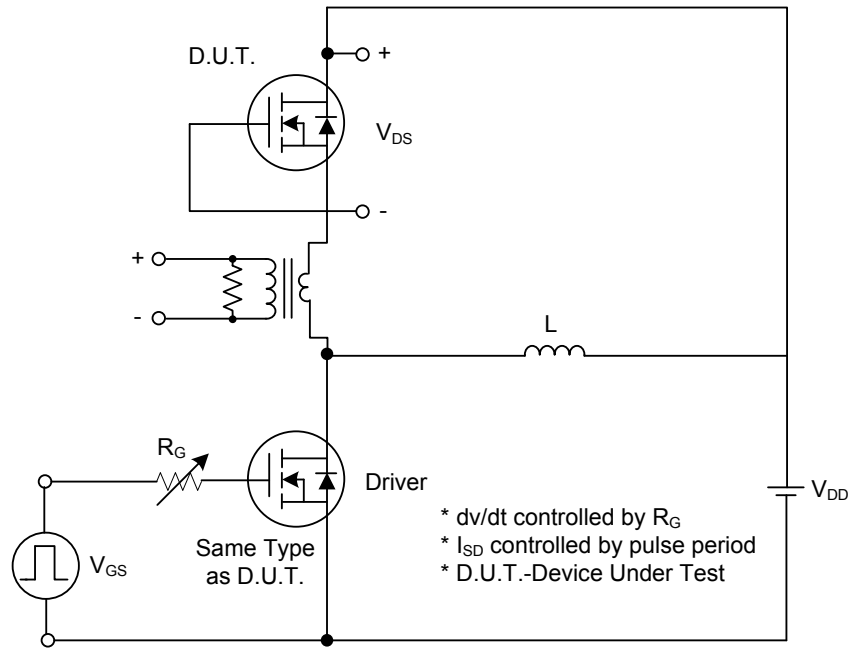

Fig. 1A Peak Diode Recovery dv/dt Test Circuit

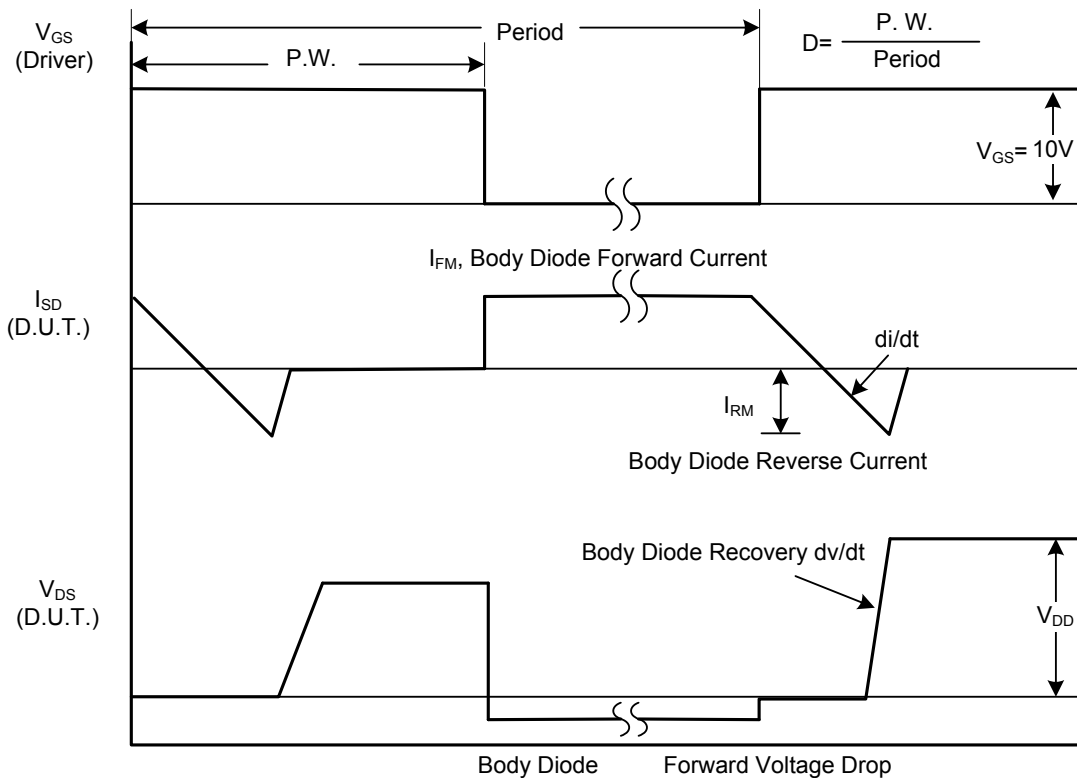

Fig. 1B Peak Diode Recovery dv/dt Waveforms

■ TEST CIRCUITS AND WAVEFORMS (Cont.)

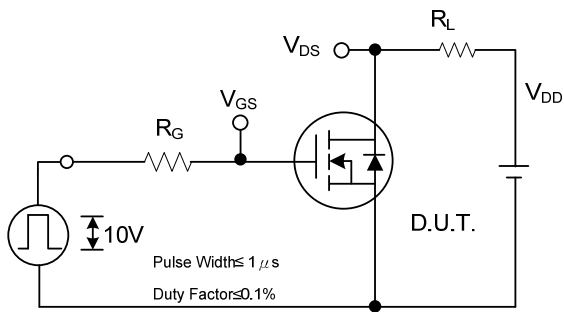

Fig. 2A Switching Test Circuit

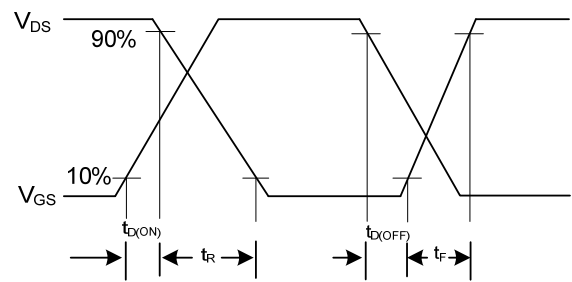

Fig. 2B Switching Waveforms

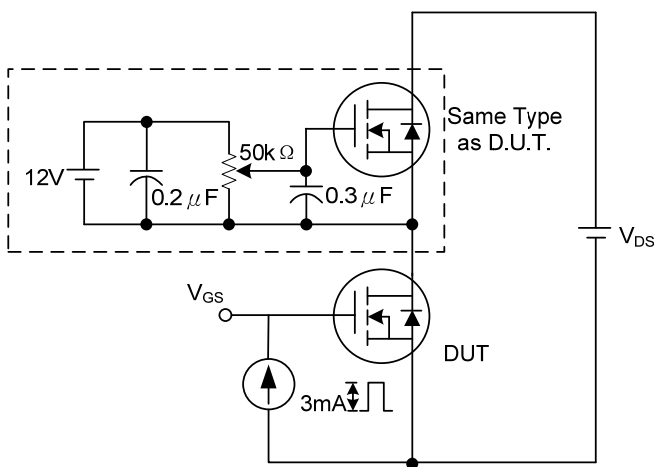

Fig. 3A Gate Charge Test Circuit

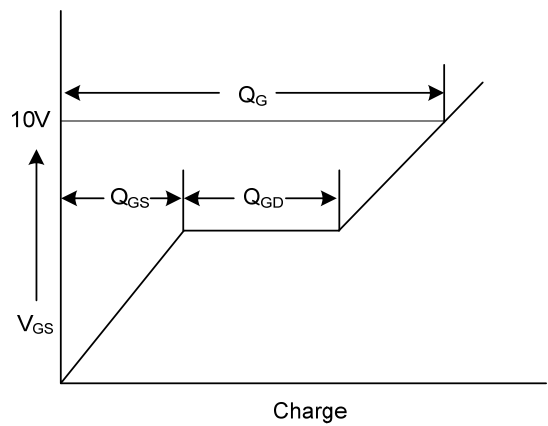

Fig. 3B Gate Charge Waveform

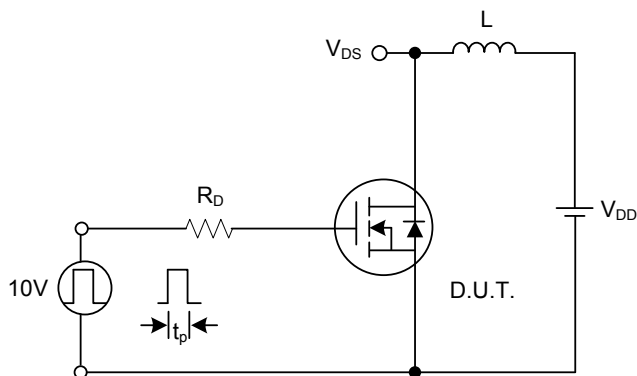

Fig. 4A Unclamped Inductive Switching Test Circuit

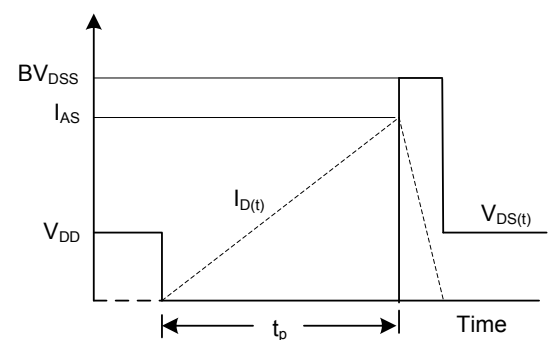
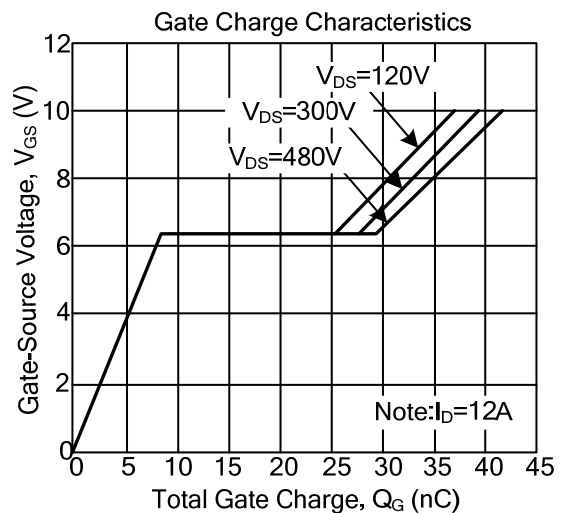
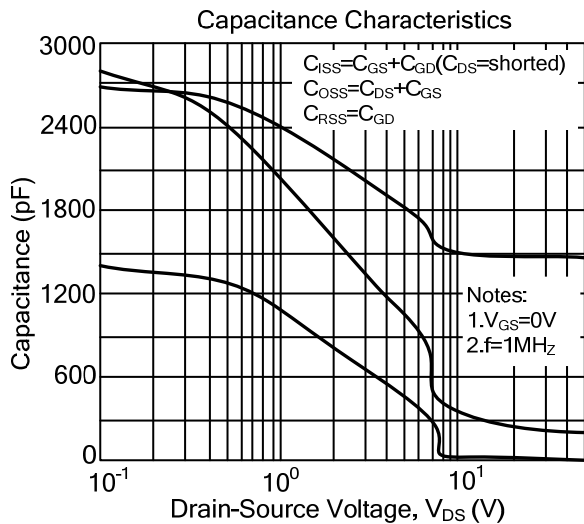
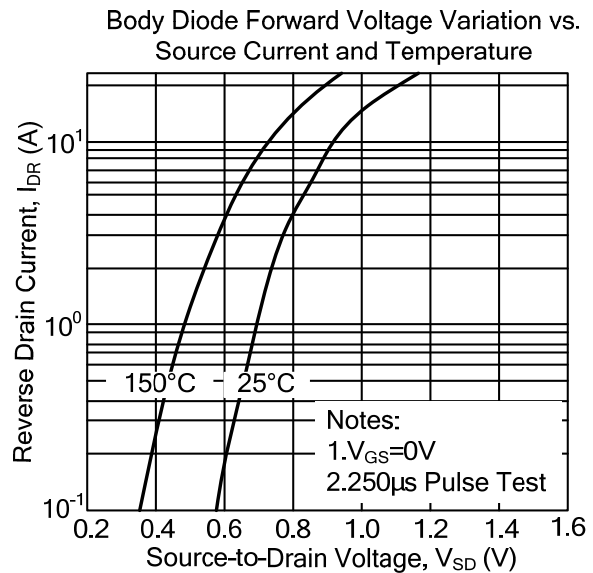
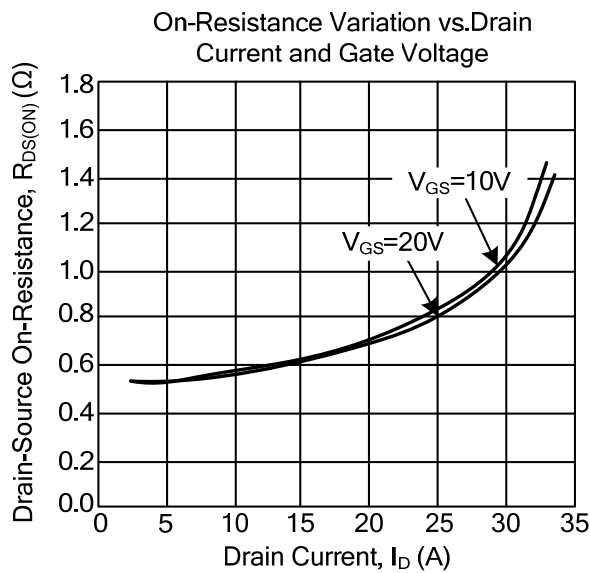
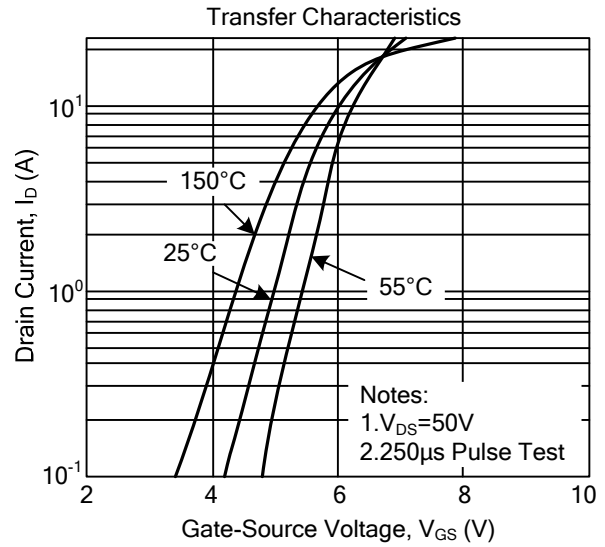
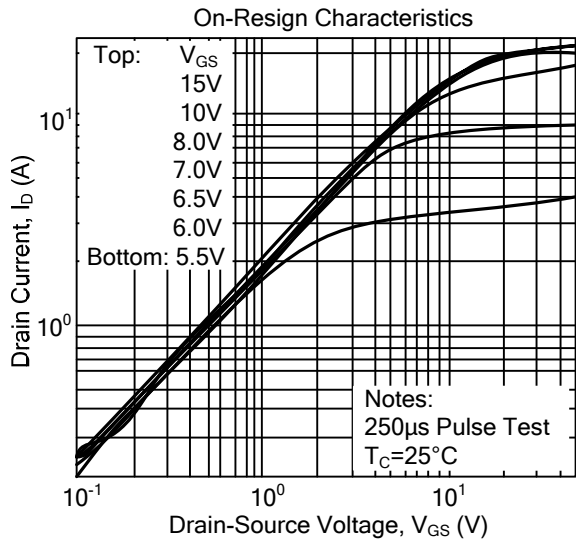
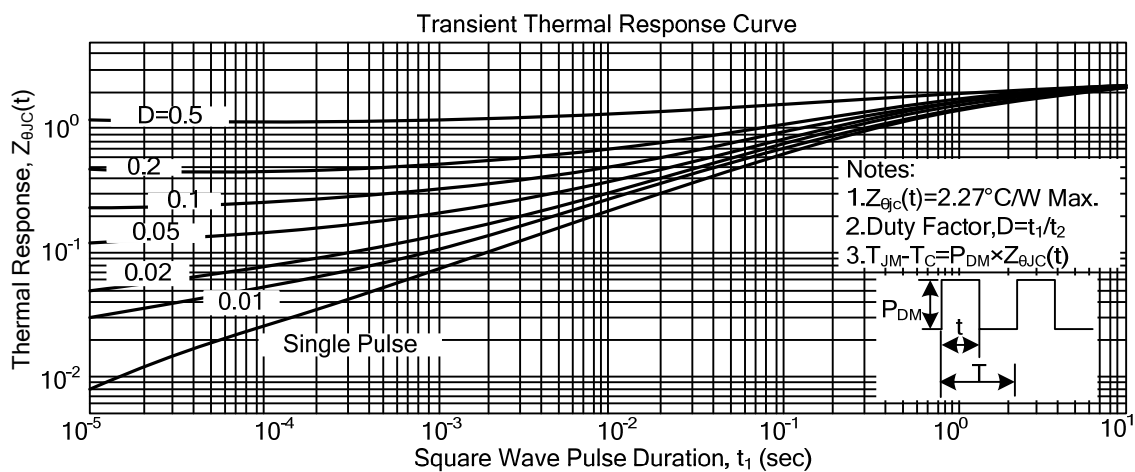
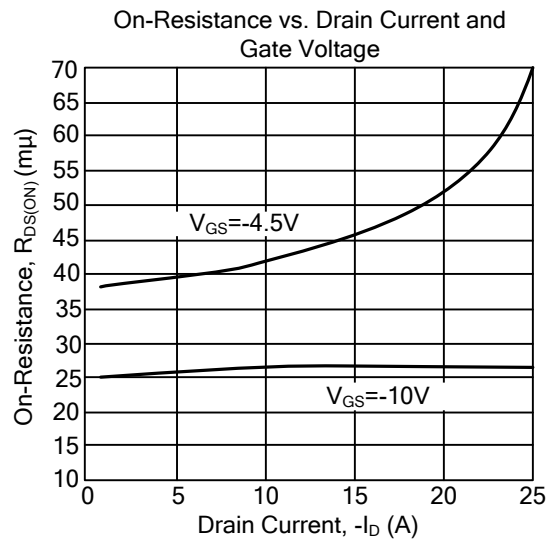
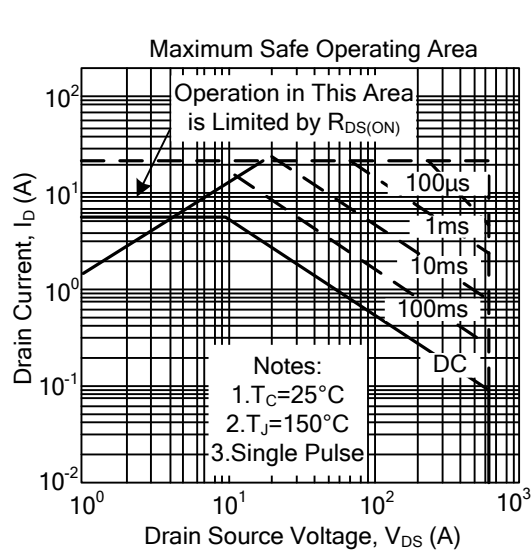

Fig. 4B Unclamped Inductive Switching Waveforms

## TYPICAL CHARACTERISTICS



## TYPICAL CHARACTERISTICS



UTC assumes no responsibility for equipment failures that result from using products at values that exceed, even momentarily, rated values (such as maximum ratings, operating condition ranges, or other parameters) listed in products specifications of any and all UTC products described or contained herein. UTC products are not designed for use in life support appliances, devices or systems where malfunction of these products can be reasonably expected to result in personal injury. Reproduction in whole or in part is prohibited without the prior written consent of the copyright owner. The information presented in this document does not form part of any quotation or contract, is believed to be accurate and reliable and may be changed without notice.