

TOLERANCE UNLESS SPECIFIED =

.XXX= +/- .005

.XX= +/- .015

FRACTIONS= +/- .032

VPP10-5600.DC2

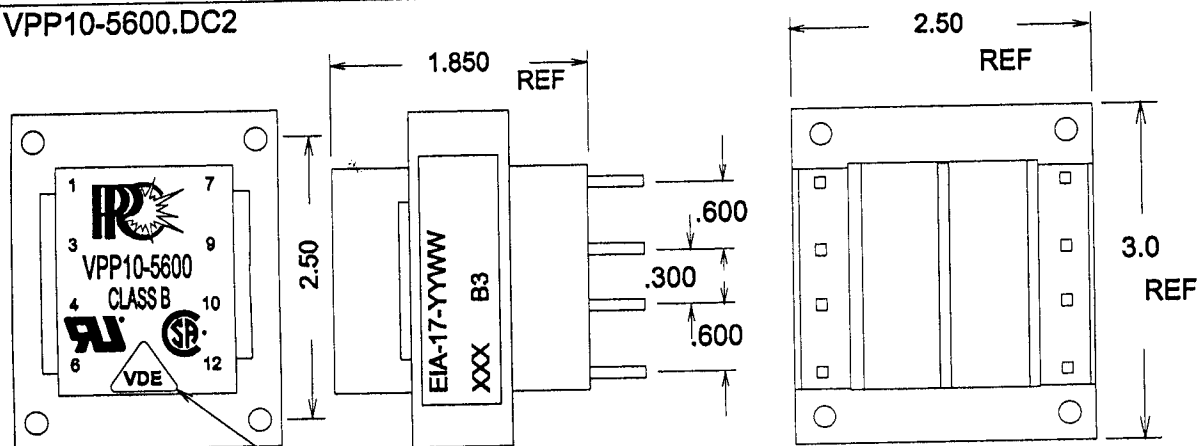

ALL MANUFACTURING SITES USE THIS MARK

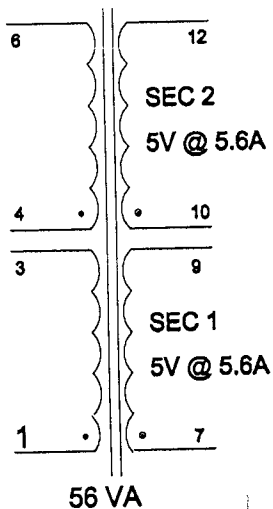

PC PINS .045 SQ

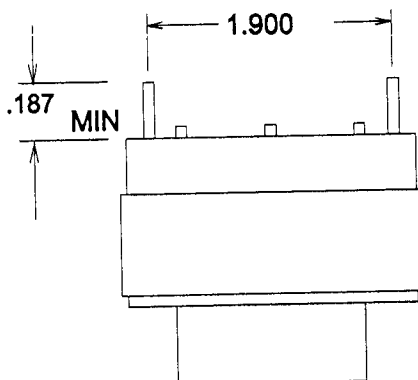

PRODUCTION TESTS

TURN'S RATIO = 100%

DC RESISTANCE IN OHMS	1-3 =	21.5 NOM
	4-6 =	26.5 NOM
	7-9 =	.061 NOM
	10-12 =	.074 NOM

MAX EXCITATION CURRENT = 75 MA

APPLY 230V 60HZ 1-6 (3+4)

PRI WDGS 114.5 TO 115.5 V

SEC WDGS 5.40 TO 5.94V

HIPOT: 4000V P-S
4000V P,S, TO CORE
600V P-P, S-S

IMPREGNATION NOTES: PREHEAT 2 HRS
PINS TO BE FREE OF IMPREGNATION.

FINAL ASSEMBLY NOTES

METHOD 1 X 1
LEAVE OFF LAST "I" PCS

MARKING SEE LABEL DETAIL ABOVE
APPLY PART NO. LABEL, AFTER IMPREGNATION



PART NO.: VPP10-5600