

# CL-421 シリーズ

Multi-Color Side-Lighting Type **CL-421 Series**

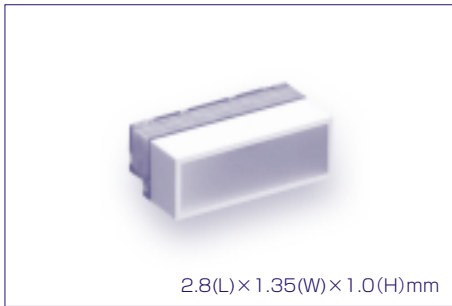

● 同一パッケージで赤、青、緑の3色に発光するチップLEDです。

● 3 colors of red, blue, and green chip LEDs in one package

## ●絶対最大定格/Absolute Maximum Rating (Ta 25°C)

Series	Lighting color	P*1 (mW)	Pd (mW)	IF (mA)	IFP (mA)	VR (V)	Top (°C)	Tst (°C)
CL-421	TR1	125	78	30	100*2	4	-25~+80	-30~+85
	MG/MB		76	20				

\*1 Pは同時点灯時の全許容損失を示します。

\*1 P means total value of power dissipation when both colors are on.

\*2 IFPの条件はduty 1/10、パルス巾30msecです。

\*2 Condition for IFP is pulse of 1/10 duty and 30msec width.

## ●電気的光学的特性/Electro-optical Characteristics (Ta 25°C)

Product code	Lighting color	VF			λp typ (nm)	Δλ typ (nm)	IV*		
		IF (mA)	typ (V)	max (V)			IF (mA)	min (mcd)	typ (mcd)
CL-421S-G	TR1	—	2.0	2.6	624	15	20	79	120
	MG	—	3.3	3.8	515	35	20	110	300
	MB	—	3.4	3.8	470	35	20	30	95

\*NIST規格に準拠

\*Per NIST standards

## ●外形寸法図/Outline drawing

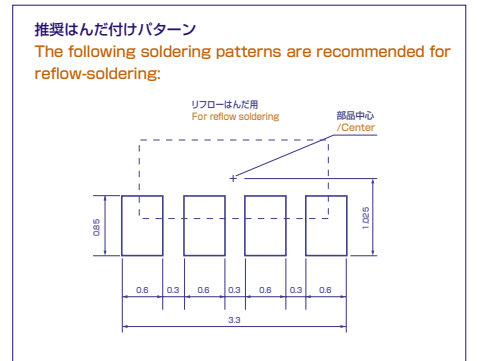
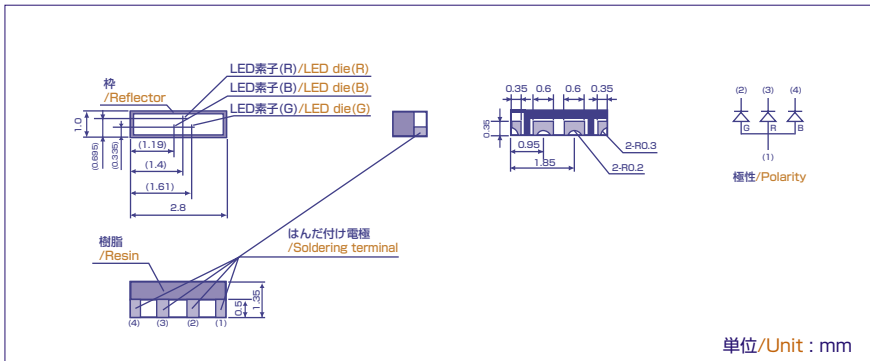

## ■ 諸特性 / Characteristics

