

LG2401281-CW 240 x 128 dots + CCFL backlight

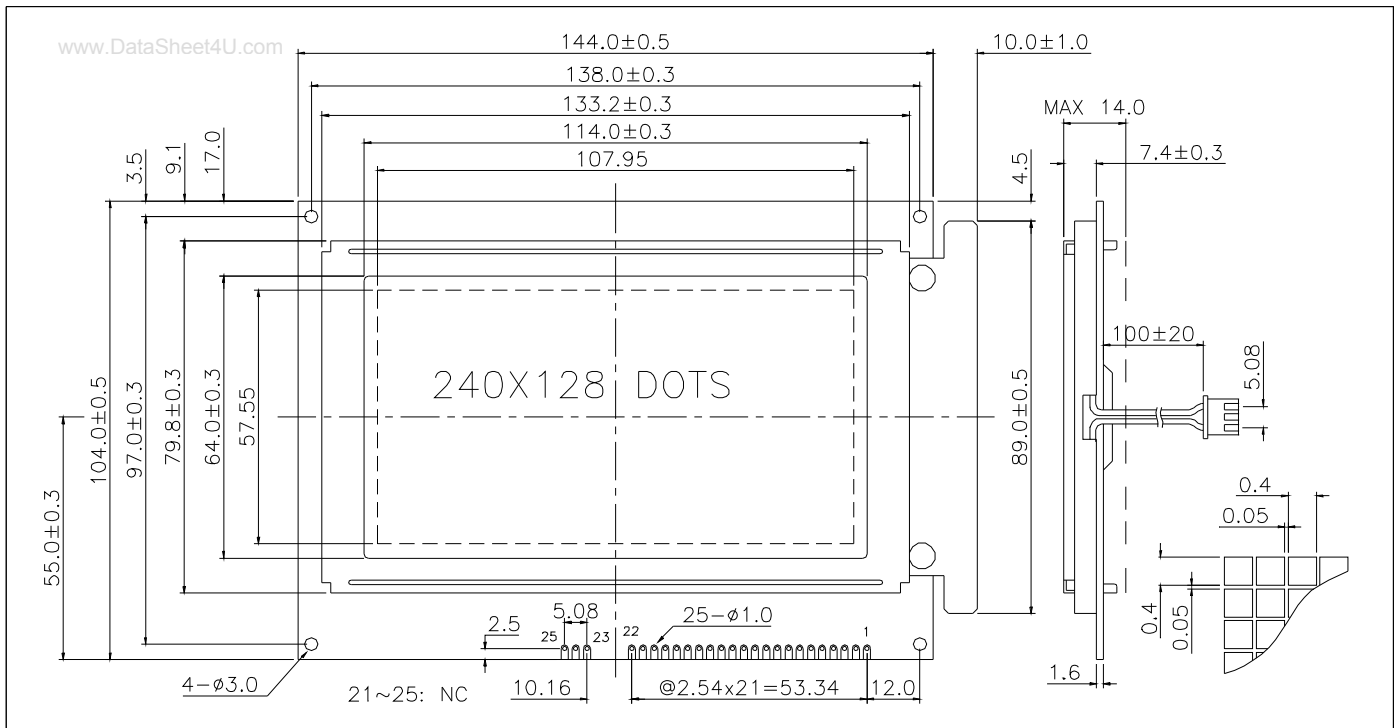

ABSOLUTE MAXIMUM RATINGS

Item	Symbol	Min.	Max.	Unit
Supply Voltage(Logic)	$V_{DD} - V_{SS}$	-0.3	7.0	V
Supply Voltage(LCD)	$V_{DD} - V_o$	-0.3	25.0	V
Input Voltage	V_i	-0.3	$V_{DD} + 0.3$	V
Operating Temp.	T_{opr}	-20	70	°C
Storage Temp.	T_{stg}	-30	80	°C

MECHANICAL DATA

Item	Nominal Dimensions	Unit
Module Size (W x H x T)	154.0 x 104.0 x 14.0	mm
Viewing Area (W x H)	114.0 x 64.0	mm
Dot Pitch (W x H)	0.45 x 0.45	mm
Dot Size (W x H)	0.40 x 0.40	mm
Weight	Approx. 190	g

ELECTRICAL CHARACTERISTICS ($V_{DD}=5V\pm0.25V$)

Item	Symbol	Test Condition	Min.	Typ.	Max.	Unit
Input High Voltage	V_{IH}	--	$V_{DD}-2.2$	--	V_{DD}	V
Input Low Voltage	V_{IL}	--	-0.3	--	0.8	V
Output High Voltage	V_{OH}	--	$V_{DD}-0.3$	--	V_{DD}	V
Output Low Voltage	V_{OL}	--	0	--	0.3	V
Supply Current	I_{DD}	$V_{DD} = 5.0V$	--	18.0	25.0	mA
LCD Driving Voltage	$V_{DD} - V_o$	$T_a=25^\circ C$	--	18.2	--	V

PIN CONNECTIONS

Pin	Symbol	Level	Function
1	FG	--	Frame ground
2	V_{SS}	0V	GND
3	V_{DD}	+5V	Power supply for logic
4	V_o	--	Operating voltage for LCD
5	/WR	L	Write signal, active "L"
6	/RD	L	Read signal, active "L"
7	/CE	L	Chip enable signal, active "L"
8	C/D	H/L	L : Data H : Instruction code
9	NC	--	No connection
10	/RST	L	Reset signal, active "L"
11	DB0	H/L	Data bus line
12	DB1	H/L	
13	DB2	H/L	
14	DB3	H/L	
15	DB4	H/L	
16	DB5	H/L	
17	DB6	H/L	
18	DB7	H/L	
19	FS	H/L	Font selection L: 8x8, H: 6x8
20	V_{OUT}	-15V	Output voltage for LCD driving

BLOCK DIAGRAM

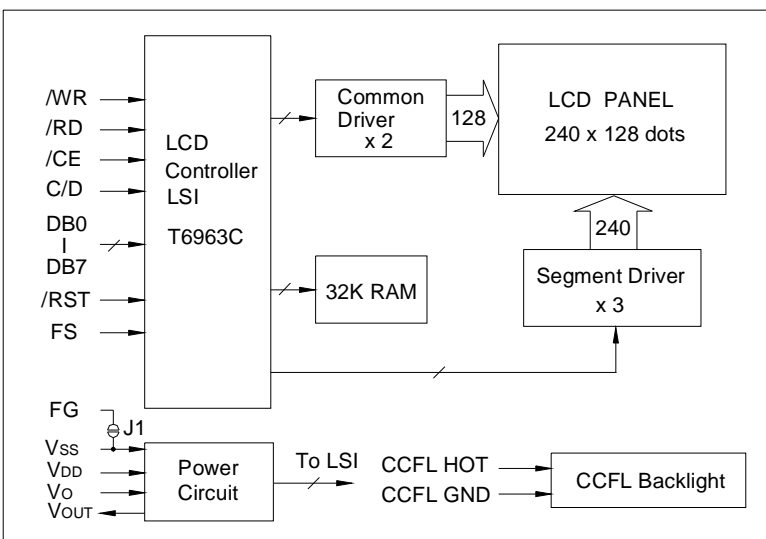

CCFL BACKLIGHT SPECIFICATIONS ($T_a=25^\circ C$)

Item	Symbol	Typ.	Max.	Unit
Tube voltage	V	250	--	V
Tube Current	I	5	--	mA
Emission Wave Length	λ_p	--	--	nm