

High Voltage 3-Phase Motor Drivers

Features and Benefits

- Built-in pre-drive IC
- MOSFET power element
- CMOS compatible input (3.3 to 5 V)
- High-side gate driver using bootstrap circuit or floating power supply
- Built-in protection circuit for controlling power supply voltage drop
- Built-in overtemperature detection circuit (TD)
- Output of fault signal during operation of protection circuits
- Output current 1.5, 2, or 2.5 A
- Small SIP (SLA 24-pin)

Packages: Power SIP

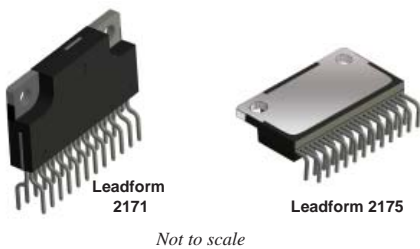

Description

The SLA6820M inverter power module (IPM) series provides a robust, highly-integrated solution for optimally controlling 3-phase motor power inverter systems and variable speed control systems used in energy-conserving designs to drive motors of residential and commercial appliances. These ICs take 230 VAC input voltage, and up to 2.5 A (continuous) output current. They can withstand voltages of up to 500 V (MOSFET breakdown voltage).

The SLA6820M power package includes an IC with all of the necessary power elements (six MOSFETs), pre-driver ICs (two), and flyback diodes (six), needed to configure the main circuit of an inverter. This enables the main circuit of the inverter to be configured with fewer external components than traditional designs.

Applications include residential white goods (home applications) and commercial appliance motor control:

- Air conditioner fan
- Small ventilation fan
- Dishwasher pump

Functional Block Diagram

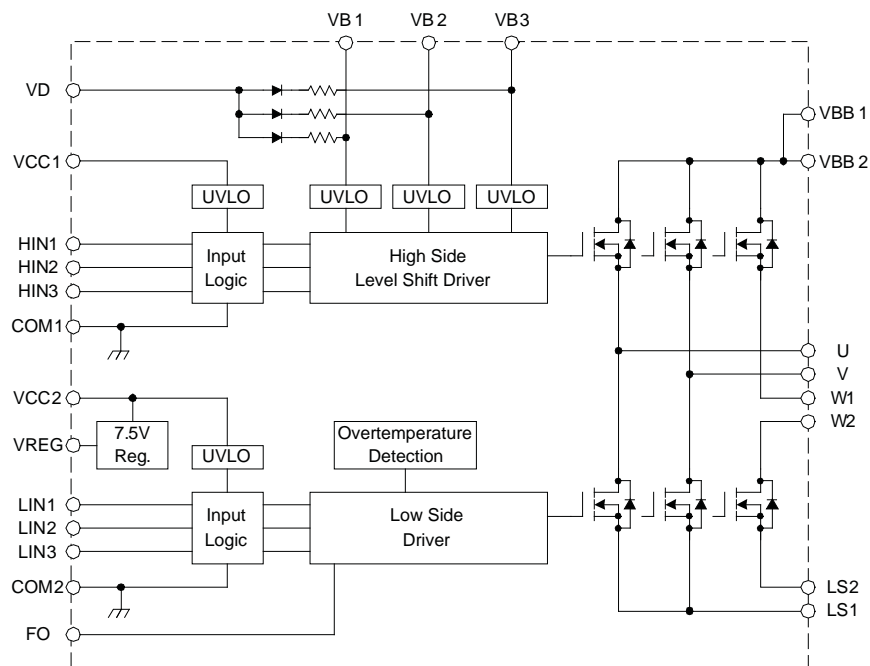

Figure 1. Driver block diagram

SLA6820M Series

High Voltage 3-Phase Motor Drivers

Selection Guide

Part Number	Packing	MOSFET Breakdown Voltage, $V_{DSS}(\text{min})$ (V)	Output Current	
			Continuous, $I_O(\text{max})$ (A)	Pulsed, $I_{OP}(\text{max})$ (A)
SLA6826M	18 pieces per tube	250	2	4
SLA6827M	18 pieces per tube	500	1.5	3
SLA6828M	18 pieces per tube	500	2.5	5

Absolute Maximum Ratings, valid at $T_A = 25^\circ\text{C}$

Characteristic	Symbol	Remarks	Rating	Unit	
MOSFET Breakdown Voltage	V_{DSS}	SLA6826M	$V_{CC} = 15\text{ V}$, $I_D = 100\ \mu\text{A}$, $V_{IN} = 0\text{ V}$	250	V
		SLA6827M		500	V
		SLA6828M		500	V
Logic Supply Voltage	V_{CC}	Between VCC and COM	20	V	
Bootstrap Voltage	V_{BS}	Between VB and HS (U,V, and W phases)	20	V	
Output Current, Continuous	I_O	SLA6826M		2	A
		SLA6827M		1.5	A
		SLA6828M		2.5	A
Output Current, Pulsed	I_{OP}	SLA6826M	$PW \leq 100\ \mu\text{s}$, duty cycle = 1%	4	A
		SLA6827M		3	A
		SLA6828M		5	A
Output Current for Regulator	I_{REG}		35	mA	
Input Voltage	V_{IN}	HINx and LINx pins	-0.5 to 7	V	
Allowable Power Dissipation	P_D	$T_C = 25^\circ\text{C}$	32.9	W	
Thermal Resistance (Junction to Case)	$R_{\theta JC}$	All elements operating	3.8	$^\circ\text{C}/\text{W}$	
Case Operating Temperature	T_{COP}		-20 to 100	$^\circ\text{C}$	
Junction Temperature (MOSFET)	T_J		150	$^\circ\text{C}$	
Storage Temperature	T_{stg}		-40 to 150	$^\circ\text{C}$	

Recommended Operating Conditions

Characteristic	Symbol	Remarks	Min.	Typ.	Max.	Units	
Main Supply Voltage	V_{BB}	SLA6826M	Between VBB and LS	-	140	200	V
		SLA6827M		-	300	400	V
		SLA6828M		-	300	400	V
Logic Supply Voltage	V_{CC}	Between VCC and COM	13.5	-	16.5	V	
Dead Time	t_{dead}		1.5	-	-	μs	
Junction Temperature	T_J		-	-	125	$^\circ\text{C}$	

All performance characteristics given are typical values for circuit or system baseline design only and are at the nominal operating voltage and an ambient temperature, T_A , of 25°C , unless otherwise stated.



Typical Application Diagram

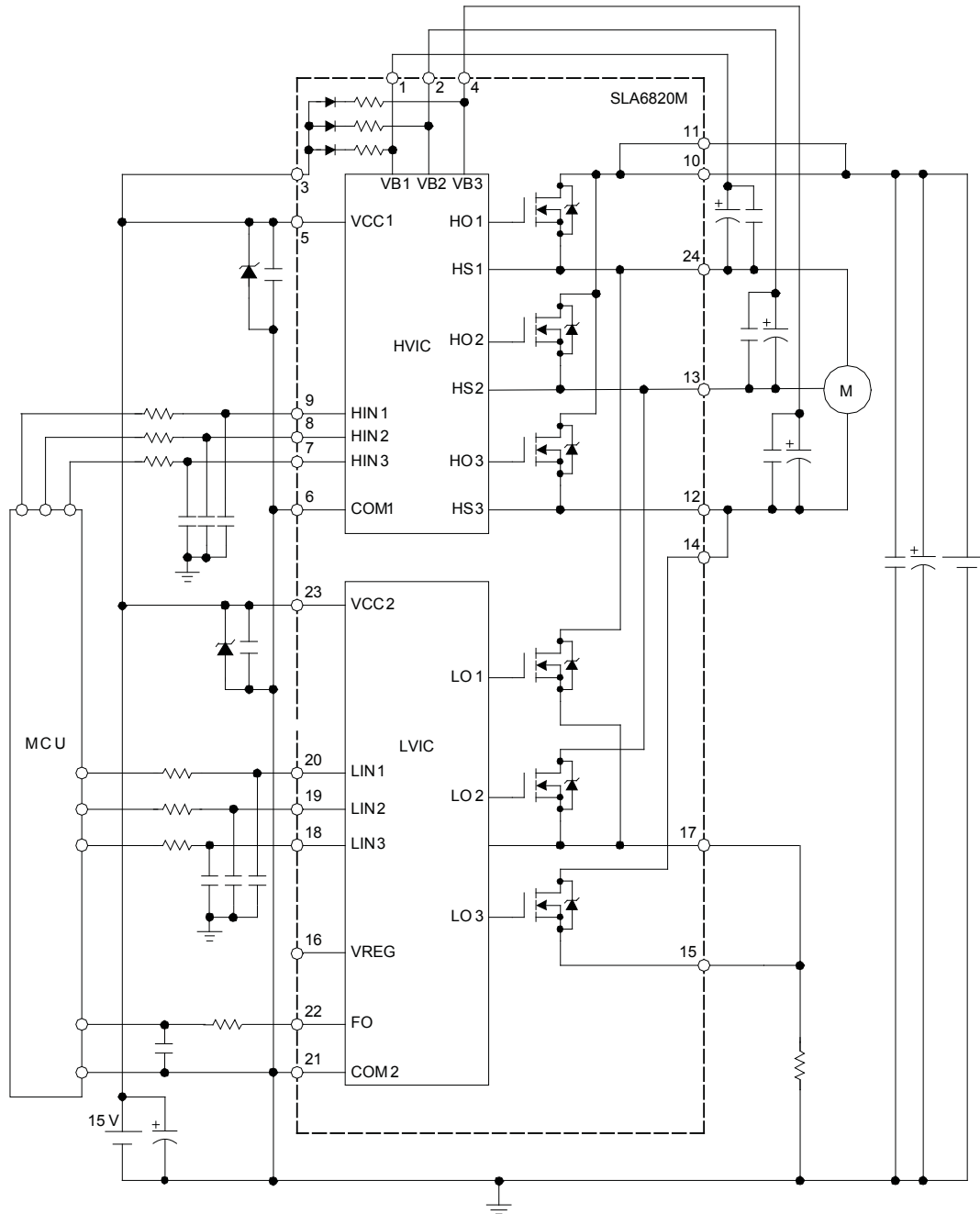

NOTE:

- All of the input pins are connected to GND with internal pull-down resistors rated at 100 kΩ, however, an external pull-down resistor may be required to secure stable condition of the inputs if high impedance conditions are applied to them.
- The external electrolytic capacitors should be placed as close to the IC as possible, in order to avoid malfunctions from external noise interference. Put a ceramic capacitor in parallel with the electrolytic capacitor if further reduction of noise susceptibility is necessary.

SLA6820M Series

High Voltage 3-Phase Motor Drivers

ELECTRICAL CHARACTERISTICS, valid at $T_A=25^{\circ}\text{C}$, unless otherwise noted

Characteristics	Symbol	Conditions	Min	Typ	Max	Units	
Logic Supply Voltage	V_{CC}	Between VCC and COM	13.5	15	16.5	V	
Logic Supply Current	I_{CC}	$V_{CC} = 15\text{ V}$, $I_{REG} = 0\text{ A}$	–	4	6	mA	
Input Voltage	V_{IH}	$V_{CC} = 15\text{ V}$, output on	–	2.0	2.5	V	
	V_{IL}	$V_{CC} = 15\text{ V}$, output off	1.0	1.5	–	V	
Input Voltage Hysteresis	V_{Ihys}	$V_{CC} = 15\text{ V}$	–	0.5	–	V	
Input Current	I_{IH}	High side, $V_{CC} = 15\text{ V}$, $V_{IN} = 5\text{ V}$	–	50	100	μA	
	I_{IL}	Low side, $V_{CC} = 15\text{ V}$, $V_{IN} = 0\text{ V}$	–	–	2	μA	
Undervoltage Lock Out	V_{UVHL}	High side, between VBx and U, V, or W	9.0	10.0	11.0	V	
	V_{UVHH}		9.5	10.5	11.5	V	
	V_{UVHhys}	High side, hysteresis	–	0.5	–	V	
	V_{UVLL}	Low side, between VCC2 and COM2	10.0	11.0	12.0	V	
	V_{UVLH}		10.5	11.5	12.5	V	
	V_{UVLhys}	Low side, hysteresis	–	0.5	–	V	
FO Terminal Output Voltage	V_{FOL}	$V_{CC} = 15\text{ V}$	0	–	1.0	V	
	V_{FOH}		4.0	–	5.5	V	
Overtemperature Detection Threshold Temperature (Activation and Deactivation)	T_{DH}	$V_{CC} = 15\text{ V}$, no heatsink	135	150	165	$^{\circ}\text{C}$	
	T_{DL}		105	120	135	$^{\circ}\text{C}$	
	T_{Dhys}		25	30	35	$^{\circ}\text{C}$	
Output Voltage for Regulator	V_{REG}	$I_{REG} = 35\text{ mA}$, $T_C = -20^{\circ}\text{C}$ to 100°C	6.75	7.5	8.25	V	
Bootstrap Diode Leakage Current	I_{LBD}	SLA6826M $V_R = 250\text{ V}$	–	5	10	μA	
		SLA6827M $V_R = 500\text{ V}$	–	5	10	μA	
		SLA6828M $V_R = 500\text{ V}$	–	–	10	μA	
Bootstrap Diode Forward Voltage	V_{FBD}	$I_F = 0.15\text{ A}$	–	1.1	1.3	V	
Bootstrap Diode Series Resistor	R_{BD}		–	22	–	Ω	
MOSFET Breakdown Voltage	V_{DSS}	SLA6826M	$V_{CC} = 15\text{ V}$, $I_D = 100\text{ }\mu\text{A}$, $V_{IN} = 0\text{ V}$	250	–	–	V
		SLA6827M		500	–	–	V
		SLA6828M		500	–	–	V
MOSFET Leakage Current	I_{DSS}	SLA6826M	$V_{CC} = 15\text{ V}$, $V_{DS} = 250\text{ V}$, $V_{IN} = 0\text{ V}$	–	–	100	μA
		SLA6827M	$V_{CC} = 15\text{ V}$, $V_{DS} = 500\text{ V}$, $V_{IN} = 0\text{ V}$	–	–	100	μA
		SLA6828M	$V_{CC} = 15\text{ V}$, $V_{DS} = 500\text{ V}$, $V_{IN} = 0\text{ V}$	–	–	100	μA
MOSFET On State Resistance	$R_{DS(on)}$	SLA6826M	$V_{CC} = 15\text{ V}$, $I_D = 1.5\text{ A}$, $V_{IN} = 5\text{ V}$	–	1.4	1.8	Ω
		SLA6827M	$V_{CC} = 15\text{ V}$, $I_D = 1\text{ A}$, $V_{IN} = 5\text{ V}$	–	3.6	4	Ω
		SLA6828M	$V_{CC} = 15\text{ V}$, $I_D = 1.5\text{ A}$, $V_{IN} = 5\text{ V}$	–	2.0	2.4	Ω
MOSFET Diode Forward Voltage	V_{SD}	$V_{CC} = 15\text{ V}$, $I_{SD} = 1.5\text{ A}$, $V_{IN} = 0\text{ V}$	–	1.1	1.5	V	
MOSFET Diode Recovery Time	t_{rr}	SLA6826M	$I_{SD} = 1.5\text{ A}$, $di/dt = 100\text{ A}/\mu\text{s}$	–	50	–	ns
		SLA6827M	$I_{SD} = 1\text{ A}$, $di/dt = 100\text{ A}/\mu\text{s}$	–	55	–	ns
		SLA6828M	$I_{SD} = 1.5\text{ A}$, $di/dt = 100\text{ A}/\mu\text{s}$	–	75	–	ns

SLA6820M Series

High Voltage 3-Phase Motor Drivers

SLA6826M SWITCHING CHARACTERISTICS, valid at $T_A=25^\circ\text{C}$, unless otherwise noted

Characteristics	Symbol	Conditions	Min	Typ	Max	Units
Switching Time, High Side	$t_{dH(on)}$	$V_{BB} = 140\text{ V}, V_{CC} = 15\text{ V}, I_D = 1\text{ A}, 0\text{ V} \leq V_{IN} \leq 5\text{ V}$	-	650	-	ns
	t_{rH}		-	100	-	ns
	$t_{dH(off)}$		-	370	-	ns
	t_{fH}		-	10	-	ns
Switching Time, Low Side	$t_{dL(on)}$	$V_{BB} = 140\text{ V}, V_{CC} = 15\text{ V}, I_D = 1\text{ A}, 0\text{ V} \leq V_{IN} \leq 5\text{ V}$	-	600	-	ns
	t_{rL}		-	100	-	ns
	$t_{dL(off)}$		-	300	-	ns
	t_{fL}		-	10	-	ns

SLA6827M SWITCHING CHARACTERISTICS, valid at $T_A=25^\circ\text{C}$, unless otherwise noted

Characteristics	Symbol	Conditions	Min	Typ	Max	Units
Switching Time, High Side	$t_{dH(on)}$	$V_{BB} = 300\text{ V}, V_{CC} = 15\text{ V}, I_D = 1.5\text{ A}, 0\text{ V} \leq V_{IN} \leq 5\text{ V}$	-	550	-	ns
	t_{rH}		-	100	-	ns
	$t_{dH(off)}$		-	420	-	ns
	t_{fH}		-	30	-	ns
Switching Time, Low Side	$t_{dL(on)}$	$V_{BB} = 300\text{ V}, V_{CC} = 15\text{ V}, I_D = 1.5\text{ A}, 0\text{ V} \leq V_{IN} \leq 5\text{ V}$	-	570	-	ns
	t_{rL}		-	100	-	ns
	$t_{dL(off)}$		-	450	-	ns
	t_{fL}		-	30	-	ns

SLA6828M SWITCHING CHARACTERISTICS, valid at $T_A=25^\circ\text{C}$, unless otherwise noted

Characteristics	Symbol	Conditions	Min	Typ	Max	Units
Switching Time, High Side	$t_{dH(on)}$	$V_{BB} = 300\text{ V}, V_{CC} = 15\text{ V}, I_D = 2.5\text{ A}, 0\text{ V} \leq V_{IN} \leq 5\text{ V}$	-	650	-	ns
	t_{rH}		-	130	-	ns
	$t_{dH(off)}$		-	540	-	ns
	t_{fH}		-	50	-	ns
Switching Time, Low Side	$t_{dL(on)}$	$V_{BB} = 300\text{ V}, V_{CC} = 15\text{ V}, I_D = 2.5\text{ A}, 0\text{ V} \leq V_{IN} \leq 5\text{ V}$	-	690	-	ns
	t_{rL}		-	150	-	ns
	$t_{dL(off)}$		-	590	-	ns
	t_{fL}		-	50	-	ns

High Side Driver Input/Output Timing Diagrams

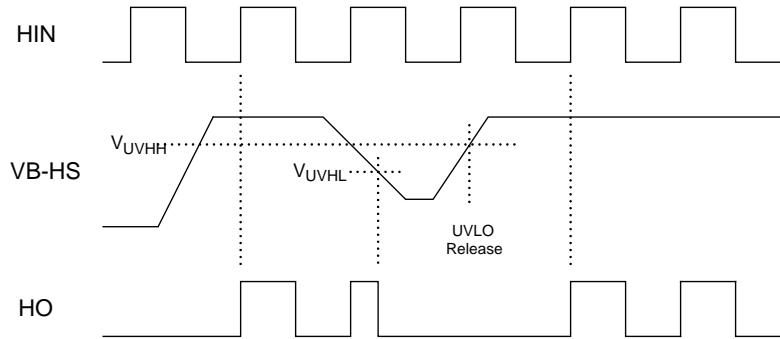

After UVLO is released, IC operation is started by the first rising edge of input

Low Side Driver Input/Output Timing Diagrams

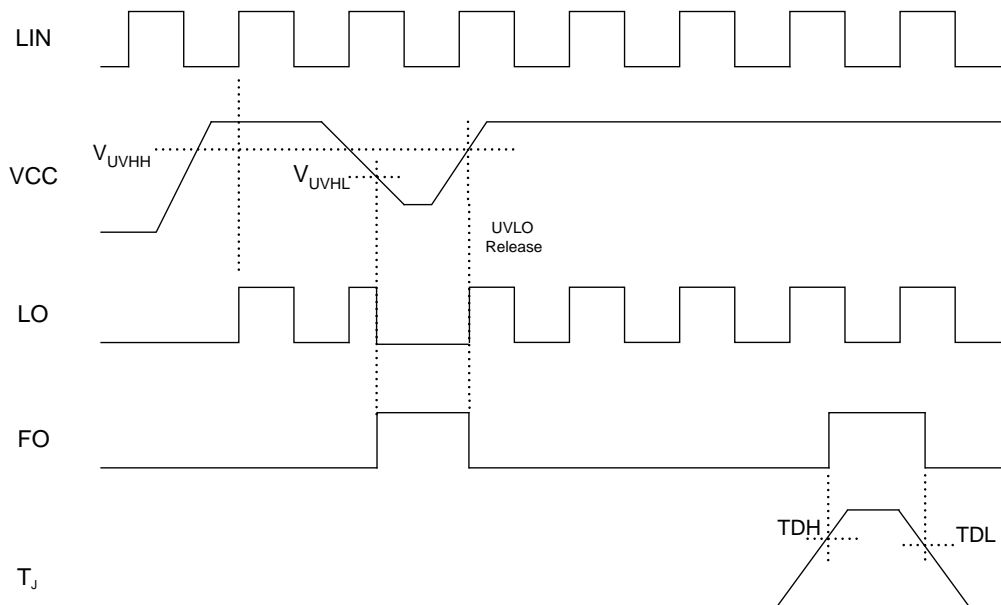

After UVLO is released, IC operation is started by the first rising edge of input

Pin-out Diagrams

Leadform 2171

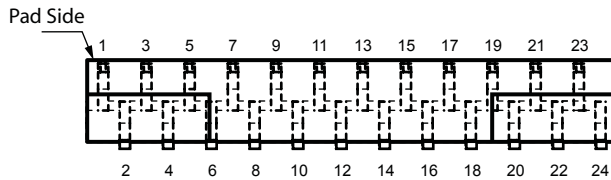

Leadform 2175

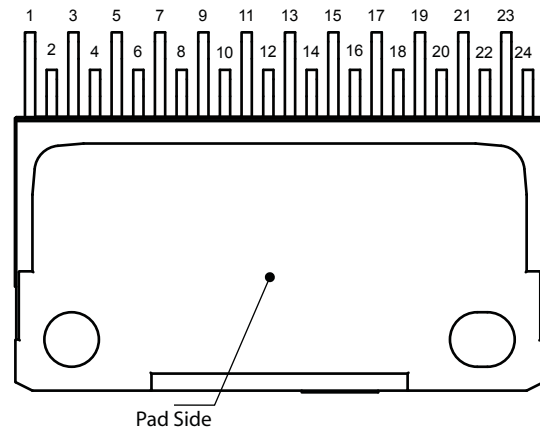

Terminal List Table

Number	Name	Function
1	VB1	High side bootstrap terminal (U phase)
2	VB2	High side bootstrap terminal (V phase)
3	VD	Bootstrap diode anode terminal
4	VB3	High side bootstrap terminal (W phase)
5	VCC1	High side logic supply voltage
6	COM1	High side logic GND terminal
7	HIN3	High side input terminal (W phase)
8	HIN2	High side input terminal (V phase)
9	HIN1	High side input terminal (U phase)
10	VBB1	Main supply voltage 1 (connect to VBB2 externally)
11	VBB2	Main supply voltage 2 (connect to VBB1 externally)
12	W1	Output of W phase (connect to W2 externally)
13	V	Output of V phase
14	W2	Output of W phase (connect to W1 externally)
15	LS2	Low side emitter terminal (connect to LS1 externally)
16	VREG	Internal regulator output terminal
17	LS1	Low side emitter terminal (connect to LS1 externally)
18	LIN3	Low side input terminal (W phase)
19	LIN2	Low side input terminal (V phase)
20	LIN1	Low side input terminal (U phase)
21	COM2	Low side GND terminal
22	FO	Overtemperature detection fault-signal output terminal
23	VCC2	Low side logic supply voltage
24	U	Output of U phase

Package Outline Drawing Leadform 2171

Dual rows, 24 alternating pins; vertical case mounting; pin #1 on tab side

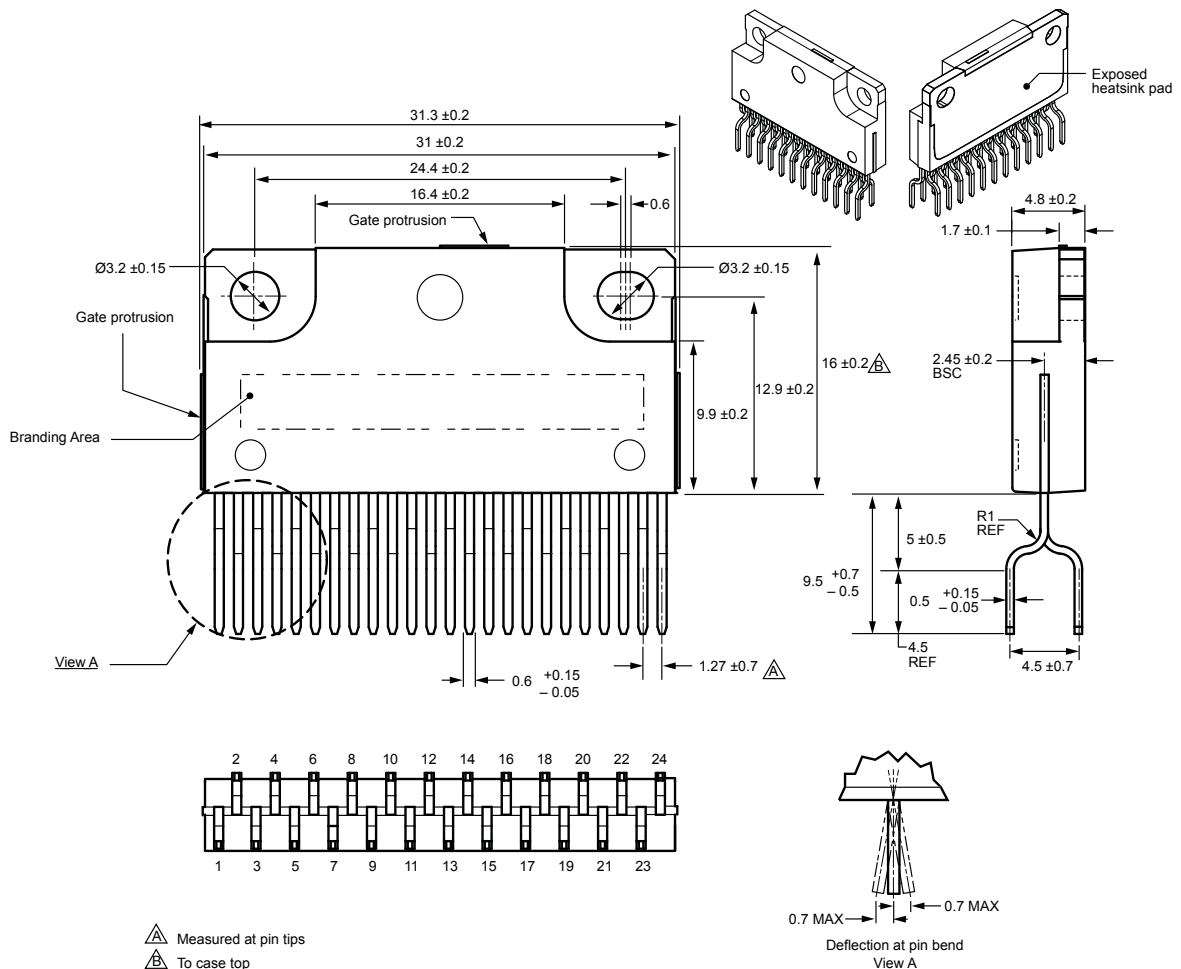

Leadform: 2171
Terminal core material: Cu
Terminal plating: Ni
Recommended attachment: Solder dip (Sn-Ag-Cu)

Dimensions in millimeters

Branding codes (exact appearance at manufacturer discretion):
1st line, type: SLA682xM

2nd line, lot: YMDD#
Where: Y is the last digit of the year of manufacture
M is the month (1 to 9, O, N, D)
DD is the date
is the tracking letter



Leadframe plating Pb-free. Device composition complies with the RoHS directive.

Package Outline Drawing Leadform 2175

Dual rows, 24 alternating pins; pins bent 90° for horizontal case mounting; pin #1 in outer row

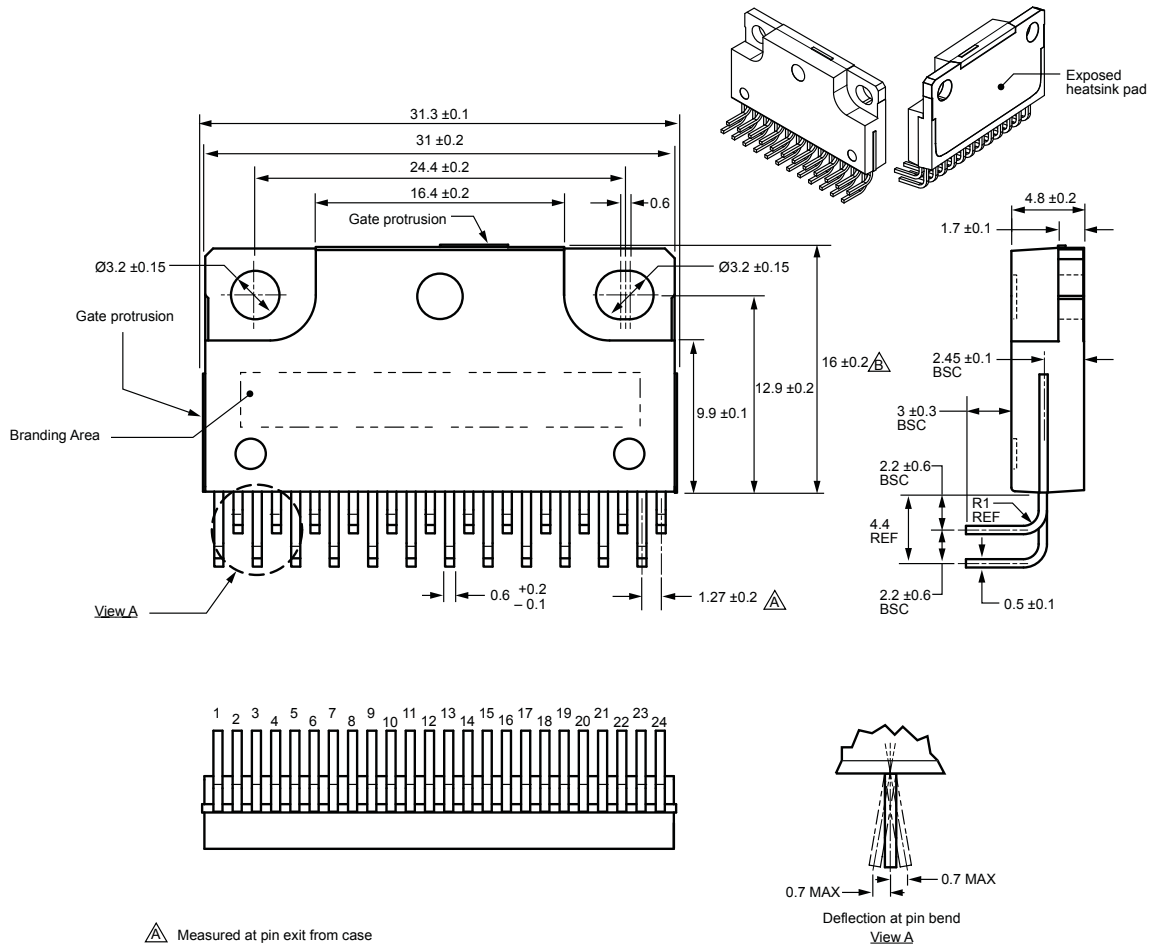

△ Measured at pin exit from case
△ To case top

Leadform: 2175
Terminal core material: Cu
Terminal plating: Ni
Recommended attachment: Solder dip (Sn-Ag-Cu)

Dimensions in millimeters

Branding codes (exact appearance at manufacturer discretion):
1st line, type: SLA682xM

2nd line, lot: YMDD#
Where: Y is the last digit of the year of manufacture
M is the month (1 to 9, O, N, D)
DD is the date
is the tracking letter



Leadframe plating Pb-free. Device composition complies with the RoHS directive.

Packing Specification

Leadform 2171

Dimensions in millimeters

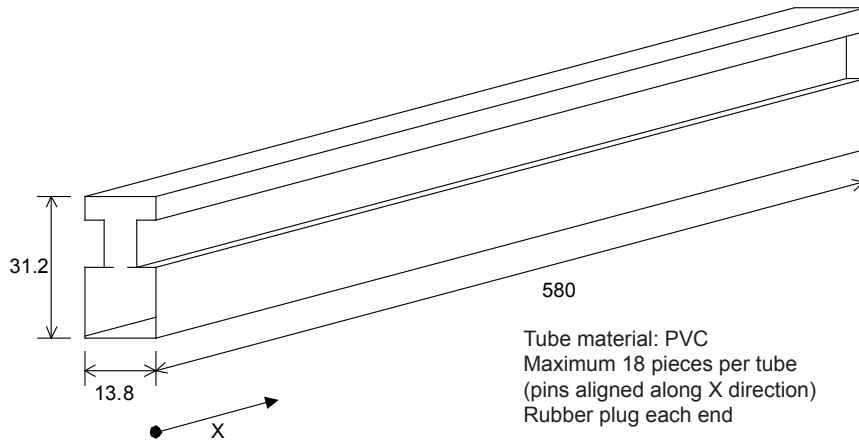

Tube material: PVC
Maximum 18 pieces per tube
(pins aligned along X direction)
Rubber plug each end

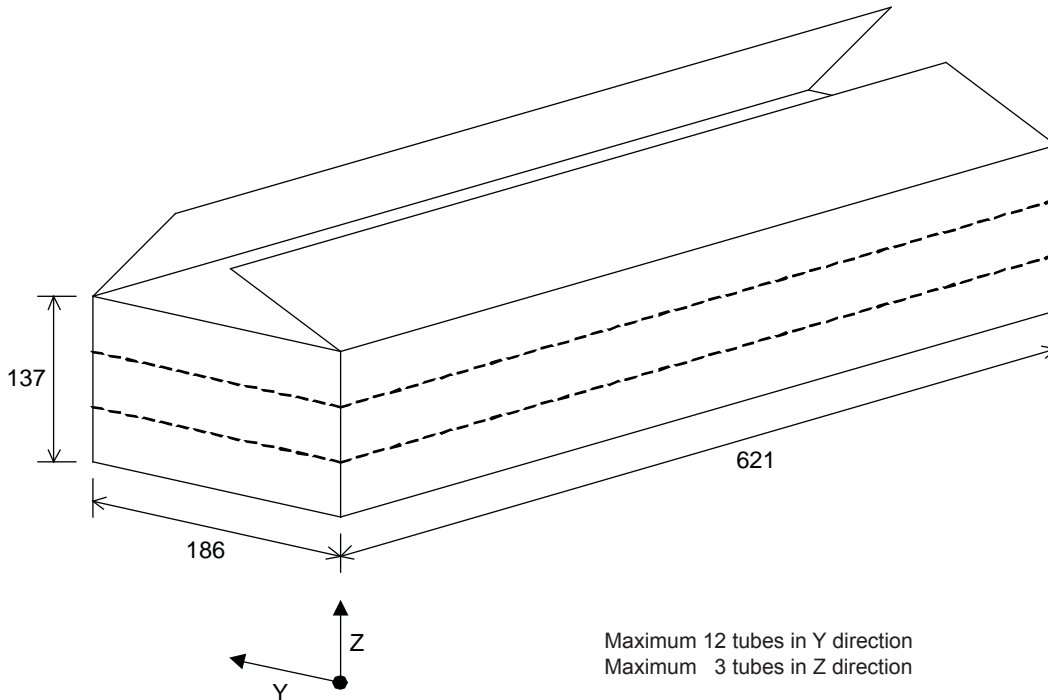

Maximum 12 tubes in Y direction
Maximum 3 tubes in Z direction

Maximum pieces per carton:

18 pieces per tube
12 tubes per layer
x 3 layers of tubes
648 pieces per carton

Packing Specification

Leadform 2175

Dimensions in millimeters

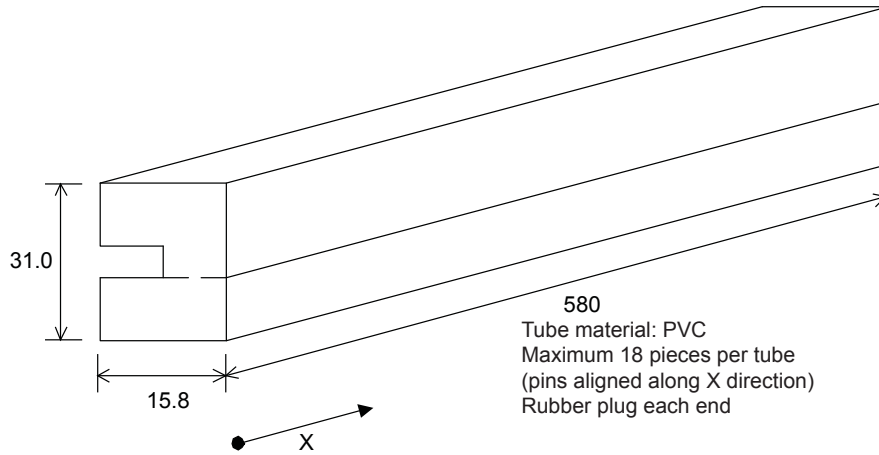

580
Tube material: PVC
Maximum 18 pieces per tube
(pins aligned along X direction)
Rubber plug each end

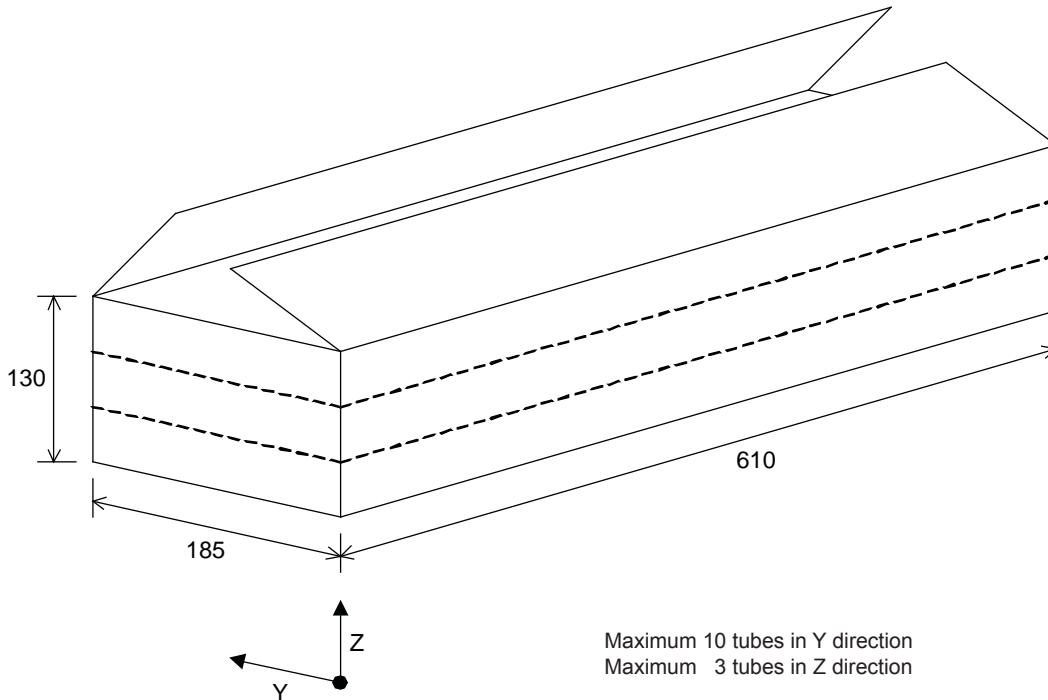

Maximum 10 tubes in Y direction
Maximum 3 tubes in Z direction

Maximum pieces per carton:
18 pieces per tube
10 tubes per layer
x 3 layers of tubes
540 pieces per carton

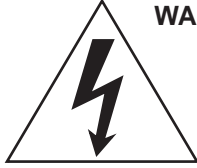

WARNING — These devices are designed to be operated at lethal voltages and energy levels. Circuit designs that embody these components must conform with applicable safety requirements. Precautions must be taken to prevent accidental contact with power-line potentials. Do not connect grounded test equipment.

The use of an isolation transformer is recommended during circuit development and breadboarding.

Because reliability can be affected adversely by improper storage environments and handling methods, please observe the following cautions.

Cautions for Storage

- Ensure that storage conditions comply with the standard temperature (5°C to 35°C) and the standard relative humidity (around 40 to 75%); avoid storage locations that experience extreme changes in temperature or humidity.
- Avoid locations where dust or harmful gases are present and avoid direct sunlight.
- Reinspect for rust on leads and solderability of products that have been stored for a long time.

Cautions for Testing and Handling

When tests are carried out during inspection testing and other standard test periods, protect the products from power surges from the testing device, shorts between adjacent products, and shorts to the heatsink.

Remarks About Using Silicone Grease with a Heatsink

- When silicone grease is used in mounting this product to a heatsink, it shall be applied evenly and thinly. If more silicone grease than required is applied, it may produce stress.
- Volatile-type silicone greases may permeate the product and produce cracks after long periods of time, resulting in reduced heat radiation effect, and possibly shortening the lifetime of the product.
- Our recommended silicone greases for heat radiation purposes, which will not cause any adverse effect on the product life, are indicated below:

Type	Suppliers
G746	Shin-Etsu Chemical Co., Ltd.
YG6260	Momentive Performance Materials, Inc.
SC102	Dow Corning Toray Silicone Co., Ltd.

Heatsink Mounting Method

Torque When Tightening Mounting Screws. The recommended tightening torque for this product package type is: 58.8 to 78.4 N•cm (6.0 to 8.0 kgf•cm).

Soldering

- When soldering the products, please be sure to minimize the working time, within the following limits:
 - 260±5°C 10 s
 - 380±5°C 5 s
- Soldering iron should be at a distance of at least 1.5 mm from the body of the products

Electrostatic Discharge

- When handling the products, operator must be grounded. Grounded wrist straps worn should have at least 1 MΩ of resistance to ground to prevent shock hazard.
- Workbenches where the products are handled should be grounded and be provided with conductive table and floor mats.
- When using measuring equipment such as a curve tracer, the equipment should be grounded.
- When soldering the products, the head of soldering irons or the solder bath must be grounded in order to prevent leak voltages generated by them from being applied to the products.
- The products should always be stored and transported in our shipping containers or conductive containers, or be wrapped in aluminum foil.

The products described herein are manufactured in Japan by Sanken Electric Co., Ltd. for sale by Allegro MicroSystems, Inc.

Sanken and Allegro reserve the right to make, from time to time, such departures from the detail specifications as may be required to permit improvements in the performance, reliability, or manufacturability of its products. Therefore, the user is cautioned to verify that the information in this publication is current before placing any order.

When using the products described herein, the applicability and suitability of such products for the intended purpose shall be reviewed at the users responsibility.

Although Sanken undertakes to enhance the quality and reliability of its products, the occurrence of failure and defect of semiconductor products at a certain rate is inevitable.

Users of Sanken products are requested to take, at their own risk, preventative measures including safety design of the equipment or systems against any possible injury, death, fires or damages to society due to device failure or malfunction.

Sanken products listed in this publication are designed and intended for use as components in general-purpose electronic equipment or apparatus (home appliances, office equipment, telecommunication equipment, measuring equipment, etc.). Their use in any application requiring radiation hardness assurance (e.g., aerospace equipment) is not supported.

When considering the use of Sanken products in applications where higher reliability is required (transportation equipment and its control systems or equipment, fire- or burglar-alarm systems, various safety devices, etc.), contact a company sales representative to discuss and obtain written confirmation of your specifications.

The use of Sanken products without the written consent of Sanken in applications where extremely high reliability is required (aerospace equipment, nuclear power-control stations, life-support systems, etc.) is strictly prohibited.

The information included herein is believed to be accurate and reliable. Application and operation examples described in this publication are given for reference only and Sanken and Allegro assume no responsibility for any infringement of industrial property rights, intellectual property rights, or any other rights of Sanken or Allegro or any third party that may result from its use.

The contents in this document must not be transcribed or copied without Sanken's written consent.

Worldwide Contacts

Asia-Pacific

China

Sanken Electric Hong Kong Co., Ltd.

Suite 1026, Ocean Centre
Canton Road, Tsimshatsui
Kowloon, Hong Kong
Tel: 852-2735-5262, Fax: 852-2735-5494

Sanken Electric (Shanghai) Co., Ltd.

Room 3202, Maxdo Centre
Xingyi Road 8, Changning District
Shanghai, China
Tel: 86-21-5208-1177, Fax: 86-21-5208-1757

Sanken Electric (Shanghai) Co., Ltd.

Shenzhen Office
Room 1013, Xinhua Insurance Building
Mintian Road, Futian District
Shenzhen City, Guangdong, China
Tel: 86-755-3391-9356/9358, Fax: 86-755-3391-9368

Taiwan Sanken Electric Co., Ltd.

Room 1801, 18th Floor
88 Jung Shiau East Road, Sec. 2
Taipei 100, Taiwan R.O.C.
Tel: 886-2-2356-8161, Fax: 886-2-2356-8261

Japan

Sanken Electric Co., Ltd.

Overseas Sales Headquarters

Metropolitan Plaza Building
1-11-1 Nishi-Ikebukuro, Toshima-ku
Tokyo 171-0021, Japan
Tel: 81-3-3986-6164, Fax: 81-3-3986-8637

Korea

Sanken Electric Korea Co., Ltd.

Samsung Life Yeouido Building 16F
23-10, Yeouido-Dong, Yeongdeungpo-gu
Seoul 150-734, Korea
Tel: 82-2-714-3700, Fax: 82-2-3272-2145

Singapore

Sanken Electric Singapore Pte. Ltd.

150 Beach Road, #14-03 The Gateway West
Singapore 189720
Tel: 65-6291-4755, Fax: 65-6297-1744

Europe

Sanken Power Systems (UK) Limited

Pencoed Technology Park
Pencoed, Bridgend CF35 5HY, United Kingdom
Tel: 44-1656-869-100, Fax: 44-1656-869-162

North America

United States

Allegro MicroSystems, Inc.

115 Northeast Cutoff
Worcester, Massachusetts 01606, U.S.A.
Tel: 1-508-853-5000, Fax: 1-508-853-7895

Allegro MicroSystems, Inc.

14 Hughes Street, Suite B105
Irvine, California 92618, U.S.A.
Tel: 1-949-460-2003, Fax: 1-949-460-7837