

# TDA8777

Triple 10-bit video DAC, up to 330 MHz sample frequency

Rev. 04 — 11 April 2006

Product data sheet

## 1. General description

---

The TDA8777 consists of three separate 10-bit video Digital-to-Analog Converters (DACs) with complementary outputs. They convert the digital input signals into analog current outputs at a maximum conversion rate of 330 MHz.

The DACs are based on current source architecture.

A sync pulse can be added to the green signal (sync-on-green) to allow devices driven by the video DAC to be synchronized.

The TDA8777 has a Power-down mode to reduce power consumption during inactive periods.

The TDA8777 is fabricated in a CMOS process that ensures high functionality with low power dissipation.

## 2. Features

---

- Triple 10-bit DAC
- Sampling frequency up to 330 MHz
- Internal voltage reference (1.21 V)
- Complementary outputs
- Direct drive of double terminated 75  $\Omega$  load into standard level
- TTL compatible input
- Sync and blank control inputs
- Analog output current source
- Power-down mode
- 3.3 V power supply
- LQFP48 package

## 3. Applications

---

- PC video cards
- High resolution image processing
- Digital video systems
- General purpose high-speed digital-to-analog conversion

**PHILIPS**

## 4. Quick reference data

Table 1. Quick reference data

Symbol	Parameter	Conditions	Min	Typ	Max	Unit
$V_{DDA}$	analog supply voltage		3.0	3.3	3.6	V
$I_{DDA}$	analog supply current		-	90	-	mA
INL	integral non-linearity		-2	-	+2	LSB
DNL	differential non-linearity		-1	-	+1	LSB
$f_{CLK}$	clock frequency					
	TDA8777HL/14/C1		-	-	140	MHz
	TDA8777HL/24/C1		-	-	240	MHz
	TDA8777HL/33/C1		-	-	330	MHz
$P_{tot}$	total power dissipation		-	297	-	mW
$I_{pd}$	current in Power-down mode		-	20	-	mA

## 5. Ordering information

Table 2. Ordering information

Type number	Package			Sampling frequency
	Name	Description	Version	
TDA8777HL/14/C1	LQFP48	plastic low profile quad flat package; 48 leads; body $7 \times 7 \times 1.4$ mm	SOT313-2	140 MHz
TDA8777HL/24/C1				240 MHz
TDA8777HL/33/C1				330 MHz

6. Block diagram

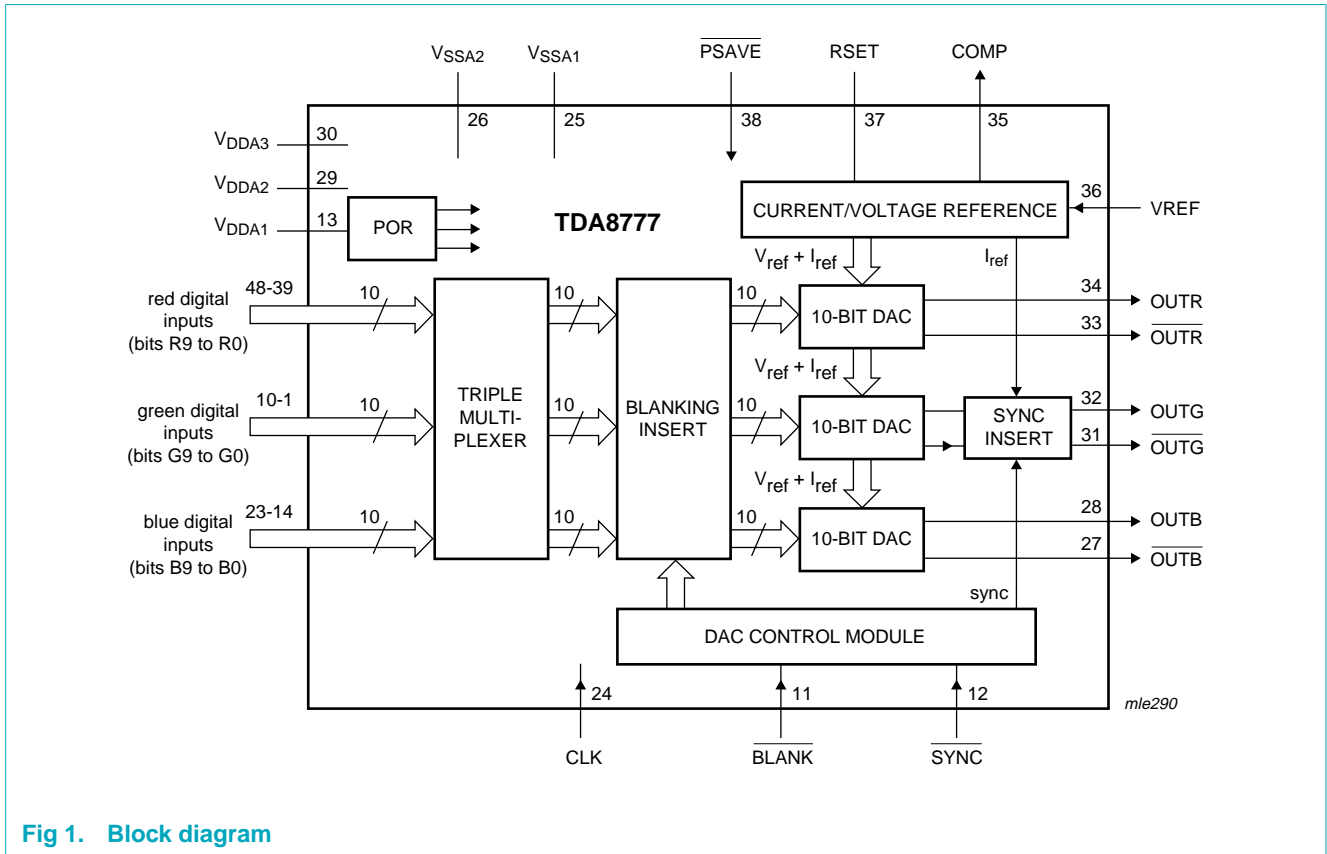

Fig 1. Block diagram

## 7. Pinning information

### 7.1 Pinning

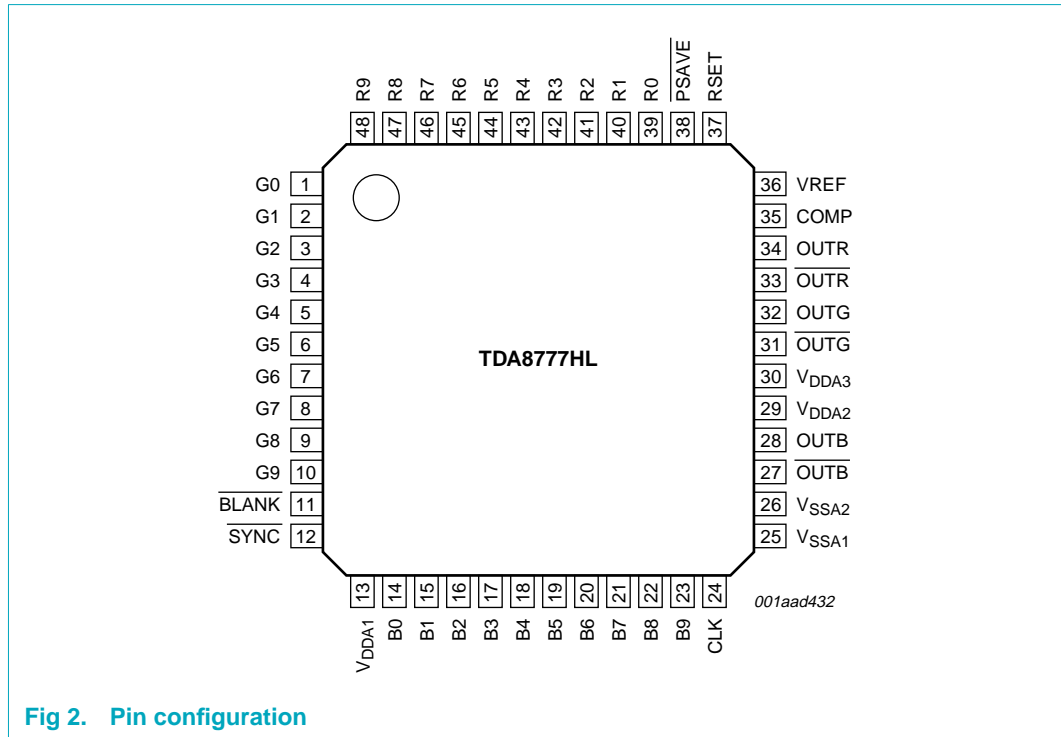

Fig 2. Pin configuration

### 7.2 Pin description

Table 3. Pin description

Symbol	Pin	Description
G0	1	green digital input data; bit 0 (LSB)
G1	2	green digital input data; bit 1
G2	3	green digital input data; bit 2
G3	4	green digital input data; bit 3
G4	5	green digital input data; bit 4
G5	6	green digital input data; bit 5
G6	7	green digital input data; bit 6
G7	8	green digital input data; bit 7
G8	9	green digital input data; bit 8
G9	10	green digital input data; bit 9 (MSB)
$\overline{\text{BLANK}}$	11	composite blank control input (active LOW)
$\overline{\text{SYNC}}$	12	composite sync control input; for green channel only (active LOW)
V <sub>D</sub> DA1	13	analog supply voltage 1
B0	14	blue digital input data; bit 0 (LSB)
B1	15	blue digital input data; bit 1
B2	16	blue digital input data; bit 2

Table 3. Pin description ...continued

Symbol	Pin	Description
B3	17	blue digital input data; bit 3
B4	18	blue digital input data; bit 4
B5	19	blue digital input data; bit 5
B6	20	blue digital input data; bit 6
B7	21	blue digital input data; bit 7
B8	22	blue digital input data; bit 8
B9	23	blue digital input data; bit 9 (MSB)
CLK	24	clock input
V <sub>SSA1</sub>	25	analog supply ground 1
V <sub>SSA2</sub>	26	analog supply ground 2
$\overline{\text{OUTB}}$	27	complementary blue current analog output
OUTB	28	blue current analog output
V <sub>DDA2</sub>	29	analog supply voltage 2
V <sub>DDA3</sub>	30	analog supply voltage 3
$\overline{\text{OUTG}}$	31	complementary green current analog output
OUTG	32	green current analog output
$\overline{\text{OUTR}}$	33	complementary red current analog output
OUTR	34	red current analog output
COMP	35	compliance voltage output
VREF	36	voltage reference input
RSET	37	full-scale current control resistor pin
$\overline{\text{PSAVE}}$	38	power-save control input (active LOW)
R0	39	red digital input data; bit 0 (LSB)
R1	40	red digital input data; bit 1
R2	41	red digital input data; bit 2
R3	42	red digital input data; bit 3
R4	43	red digital input data; bit 4
R5	44	red digital input data; bit 5
R6	45	red digital input data; bit 6
R7	46	red digital input data; bit 7
R8	47	red digital input data; bit 8
R9	48	red digital input data; bit 9 (MSB)

## 8. Functional description

This triple 10-bit video DAC is designed to convert digital input signals into analog output currents. All inputs (clock, data, blank and sync) must be TLL levels.

### 8.1 Voltage reference

The voltage reference input to pin VREF should be 1.21 V. For correct operation, a 100 nF capacitor should be connected between pin VREF and pin V<sub>DDA</sub>.

An external reference resistor must be connected between pin RSET and analog ground. This resistor sets the reference current which determines the analog output level, and is specified to be 560  $\Omega$ . This value allows a 1 V (p-p) output (video plus sync) into a 37.5  $\Omega$  load, such as a double-terminated 75  $\Omega$  coaxial cable.

## 8.2 Blanking and sync pulse insertion

The video signal (see [Figure 3](#)) is comprised of the following three parts:

- The video information: defined by the 10 bits used to drive the DAC; nominal signal amplitude = 700 mV (p-p)
- The sync pulse: a horizontal synchronization (hsync) pulse indicates the end of a video line and the start of the next video line; sync nominal amplitude = 300 mV; sync is added to the video signal output via the  $\overline{\text{SYNC}}$  input (active LOW)
- The blanking period: allows interface-free detection of both sync and video, blanking is allocated either side of the sync pulse; the blank level is equal to the video black level; blanking is added to the video signal output via the  $\overline{\text{BLANK}}$  input (active LOW).

The values of  $\overline{\text{SYNC}}$  and  $\overline{\text{BLANK}}$  are latched on the rising edge of the clock signal. When no sync and no blank are applied, the DAC can be used continuously. This is the so-called generic mode.

Because the signal delay in the DAC is 1.5 times the clock period, the sync and blank are also delayed by 1.5 times the clock period.

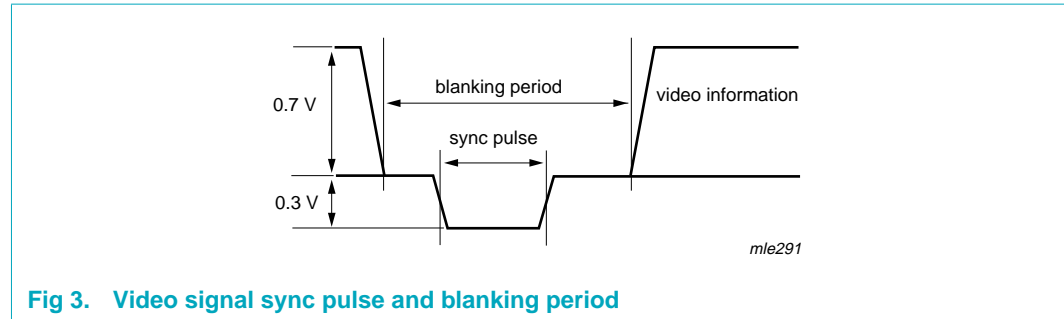

Fig 3. Video signal sync pulse and blanking period

## 9. Limiting values

Table 4. Limiting values

In accordance with the Absolute Maximum Rating System (IEC 60134).

Symbol	Parameter	Conditions	Min	Max	Unit
$V_{\text{DDA}}$	analog supply voltage	referred to $V_{\text{SSA1}}$	-0.5	+6.5	V
$V_{\text{n}}$	voltage on digital input pins	referred to $V_{\text{SSA2}}$	-0.5	+5.5	V
$T_{\text{stg}}$	storage temperature		-55	+150	$^{\circ}\text{C}$
$T_{\text{amb}}$	ambient temperature		0	70	$^{\circ}\text{C}$
$T_{\text{j}}$	junction temperature		-40	+125	$^{\circ}\text{C}$

## 10. Thermal characteristics

**Table 5. Thermal characteristics**

Symbol	Parameter	Conditions	Typ	Unit
$R_{th(j-a)}$	thermal resistance from junction to ambient	in free air for SOT313-2	88	K/W

## 11. Characteristics

**Table 6. Characteristics**

Typical values measured at  $V_{DDA} = 3.3\text{ V}$ ;  $R_{RSET} = 560\ \Omega$ ;  $T_{amb} = 25\ ^\circ\text{C}$ ; unless otherwise specified.

Symbol	Parameter	Conditions	Min	Typ	Max	Unit
<b>Supplies</b>						
$V_{DDA}$	analog supply voltage		3.0	3.3	3.6	V
$I_{DDA}$	analog supply current		-	90	-	mA
$P_{tot}$	total power dissipation		-	297	-	mW
$I_{pd}$	current in Power-down mode		-	20	-	mA
<b>Inputs</b>						
$V_{IL}$	LOW-level input voltage		-	-	0.8	V
$V_{IH}$	HIGH-level input voltage		2.0	-	-	V
$I_{IL}$	LOW-level input current		-	-	80	$\mu\text{A}$
$I_{IH}$	HIGH-level input current		-	-	120	$\mu\text{A}$
$C_{IN}$	input capacitance		-	5	-	pF
<b>Band gap reference</b>						
$V_{DDA}$	analog supply voltage		3.0	3.3	3.6	V
$I_{DDA}$	analog supply current		-	2.7	-	mA
$V_{VREF}$	reference voltage input		-	1.23	-	V
$R_{RSET}$	resistor for reference current		-	560	-	$\Omega$
<b>Digital-to-analog converter</b>						
$RES_{DAC}$	DAC resolution		-	-	10	bits
$\Delta I_{o(DAC)}$	DAC to DAC output current matching		-	-	4	%
INL	integral non-linearity		-1.8	-	+1.8	LSB
DNL	differential non-linearity		-0.9	-	+0.9	LSB
$DAC_{CT}$	DAC to DAC crosstalk		-	54	-	dB
THD	total harmonic distortion	$f_{CLK} = 140\text{ MHz}$				
		$f_{OUT} = 1\text{ MHz}$	-	60	-	dB
		$f_{OUT} = 2.2\text{ MHz}$	-	60	-	dB
		$f_{OUT} = 4.7\text{ MHz}$	-	60	-	dB
		$f_{OUT} = 12\text{ MHz}$	-	59	-	dB
		$f_{OUT} = 22\text{ MHz}$	-	58	-	dB
		$f_{OUT} = 39\text{ MHz}$	-	57	-	dB

**Table 6. Characteristics ...continued**

Typical values measured at  $V_{DDA} = 3.3\text{ V}$ ;  $R_{RSET} = 560\ \Omega$ ;  $T_{amb} = 25\ ^\circ\text{C}$ ; unless otherwise specified.

Symbol	Parameter	Conditions	Min	Typ	Max	Unit		
THD	total harmonic distortion	$f_{CLK} = 240\text{ MHz}$						
		$f_{OUT} = 1\text{ MHz}$	-	60	-	dB		
		$f_{OUT} = 2.2\text{ MHz}$	-	60	-	dB		
		$f_{OUT} = 4.7\text{ MHz}$	-	60	-	dB		
		$f_{OUT} = 12\text{ MHz}$	-	60	-	dB		
		$f_{OUT} = 22\text{ MHz}$	-	54	-	dB		
		$f_{OUT} = 39\text{ MHz}$	-	51	-	dB		
		$f_{CLK} = 330\text{ MHz}$						
		$f_{OUT} = 1\text{ MHz}$	-	60	-	dB		
		$f_{OUT} = 2.2\text{ MHz}$	-	60	-	dB		
		$f_{OUT} = 4.7\text{ MHz}$	-	60	-	dB		
		$f_{OUT} = 12\text{ MHz}$	-	60	-	dB		
		$f_{OUT} = 22\text{ MHz}$	-	53	-	dB		
		$f_{OUT} = 39\text{ MHz}$	-	47	-	dB		
		SFDR	spurious-free dynamic range to Nyquist limit	$f_{CLK} = 140\text{ MHz}$				
				$f_{OUT} = 1\text{ MHz}$	-	62	-	dB
				$f_{OUT} = 2.2\text{ MHz}$	-	62	-	dB
				$f_{OUT} = 4.7\text{ MHz}$	-	63	-	dB
$f_{OUT} = 12\text{ MHz}$	-			63	-	dB		
$f_{OUT} = 22\text{ MHz}$	-			61	-	dB		
$f_{OUT} = 39\text{ MHz}$	-			61	-	dB		
$f_{CLK} = 240\text{ MHz}$								
$f_{OUT} = 1\text{ MHz}$	-			61	-	dB		
$f_{OUT} = 2.2\text{ MHz}$	-			61	-	dB		
$f_{OUT} = 4.7\text{ MHz}$	-			63	-	dB		
$f_{OUT} = 12\text{ MHz}$	-			58	-	dB		
$f_{OUT} = 22\text{ MHz}$	-			58	-	dB		
$f_{OUT} = 39\text{ MHz}$	-			54	-	dB		
$f_{CLK} = 330\text{ MHz}$								
$f_{OUT} = 1\text{ MHz}$	-			59	-	dB		
$f_{OUT} = 2.2\text{ MHz}$	-			60	-	dB		
$f_{OUT} = 4.7\text{ MHz}$	-			54	-	dB		
$f_{OUT} = 12\text{ MHz}$	-			56	-	dB		
$f_{OUT} = 22\text{ MHz}$	-			55	-	dB		
$f_{OUT} = 39\text{ MHz}$	-			49	-	dB		

**Outputs**

$V_{O(\text{compl})}$	output voltage compliance	0	-	1.4	V
$C_{OUT}$	output capacitance	-	10	-	pF



**Table 6. Characteristics ...continued**

Typical values measured at  $V_{DDA} = 3.3\text{ V}$ ;  $R_{RSET} = 560\ \Omega$ ;  $T_{amb} = 25\text{ }^\circ\text{C}$ ; unless otherwise specified.

Symbol	Parameter	Conditions	Min	Typ	Max	Unit
<b>Timing</b>						
$f_{CLK}$	clock frequency					
	TDA8777HL/14/C1		140	-	-	MHz
	TDA8777HL/24/C1		240	-	-	MHz
	TDA8777HL/33/C1		330	-	-	MHz
$t_{d(p)}$	pipeline delay	in clock cycles	2.5	2.5	2.5	
$t_{su(i)}$	input set-up time	see <a href="#">Figure 4</a>	0	-	-	ns
$t_{h(i)}$	input hold time	see <a href="#">Figure 4</a>	1.45	-	-	ns
$t_{d(o)}$	output delay time	see <a href="#">Figure 4</a>	-	3.75	-	ns

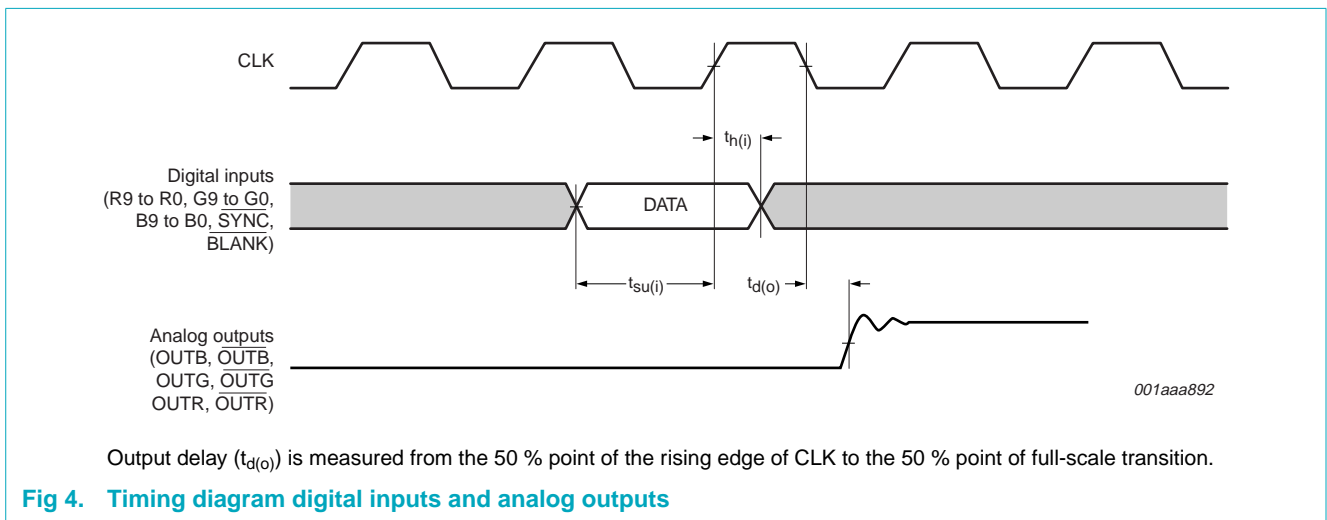

**Fig 4. Timing diagram digital inputs and analog outputs**

12. Application information

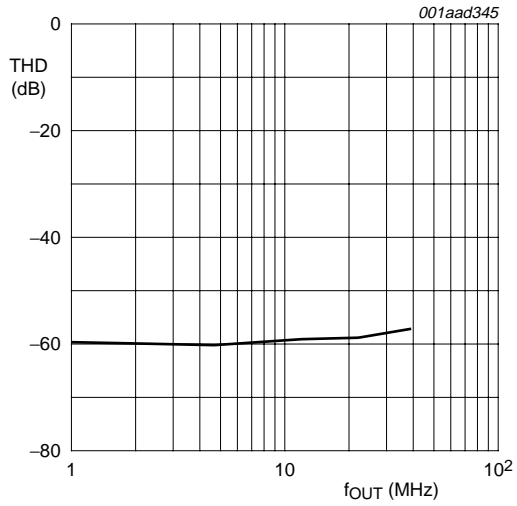

Sampling frequency = 140 MHz.

Fig 5. THD as a function of f<sub>OUT</sub>, typical values

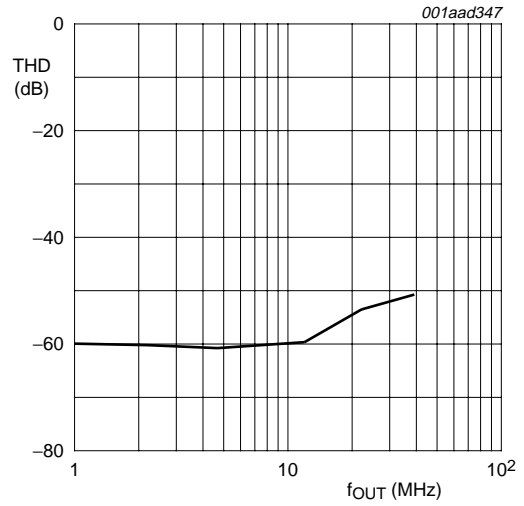

Sampling frequency = 240 MHz.

Fig 6. THD as a function of f<sub>OUT</sub>, typical values

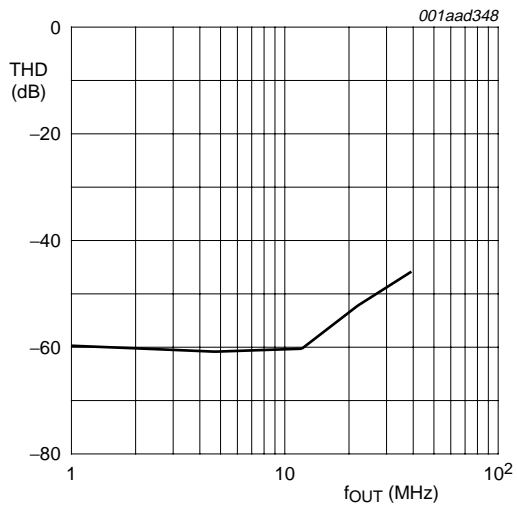

Sampling frequency = 330 MHz.

Fig 7. THD as a function of f<sub>OUT</sub>, typical values

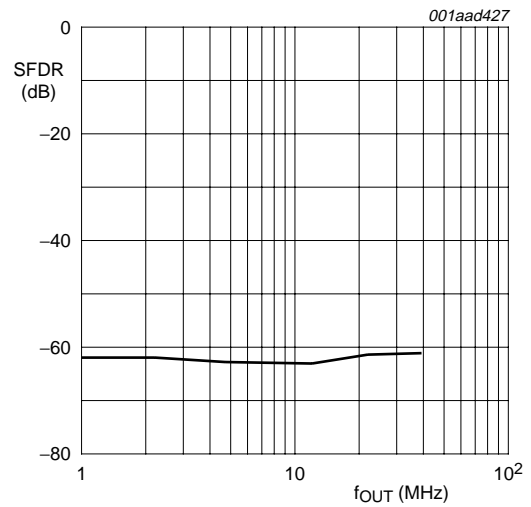

Sampling frequency = 140 MHz.

Fig 8. SFDR as a function of f<sub>OUT</sub>, typical values

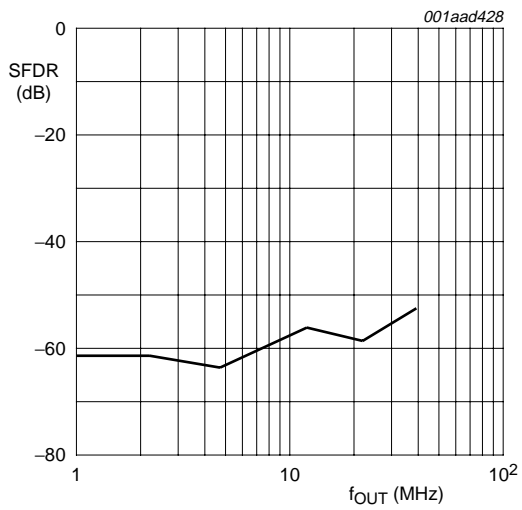

Sampling frequency = 240 MHz

Fig 9. SFDR as a function of  $f_{OUT}$ , typical values.

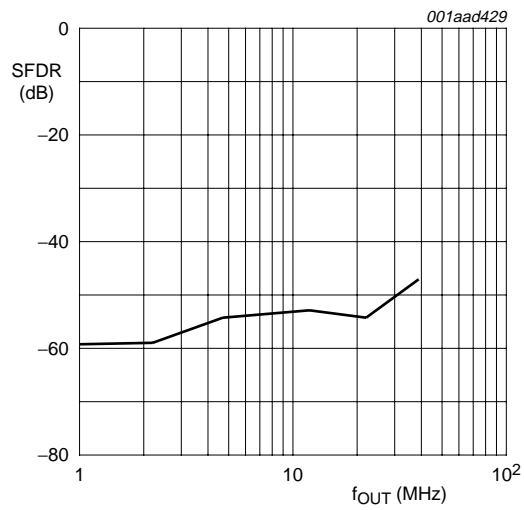

Sampling frequency = 330 MHz.

Fig 10. SFDR as a function of  $f_{OUT}$ , typical values

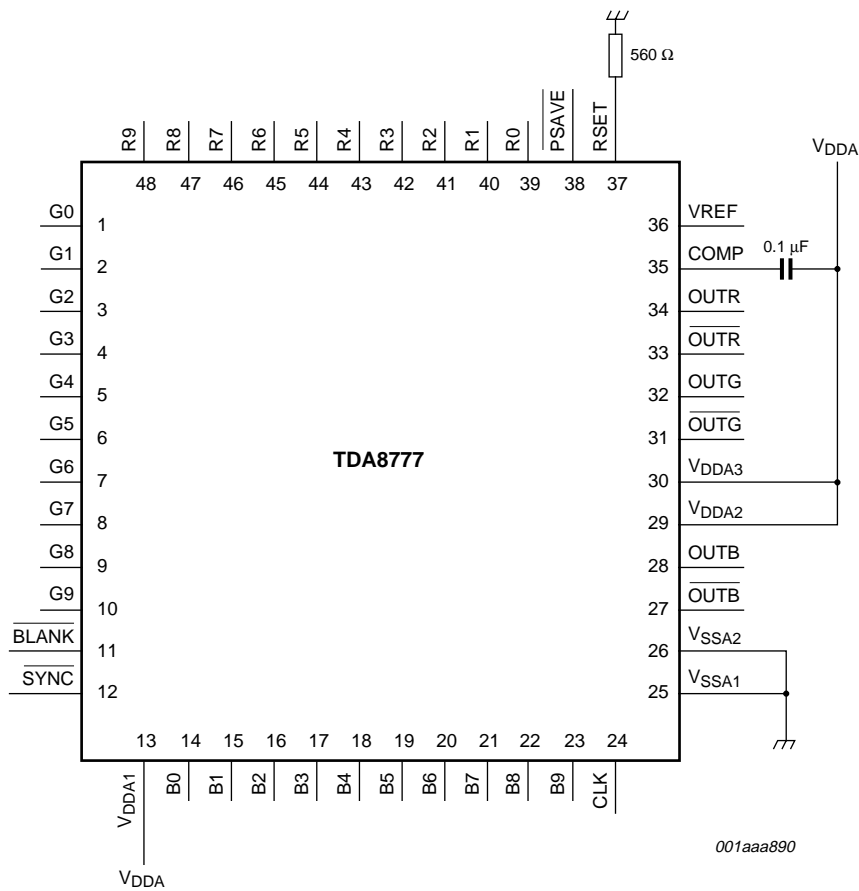

Fig 11. Application diagram

13. Package outline

LQFP48: plastic low profile quad flat package; 48 leads; body 7 x 7 x 1.4 mm

SOT313-2

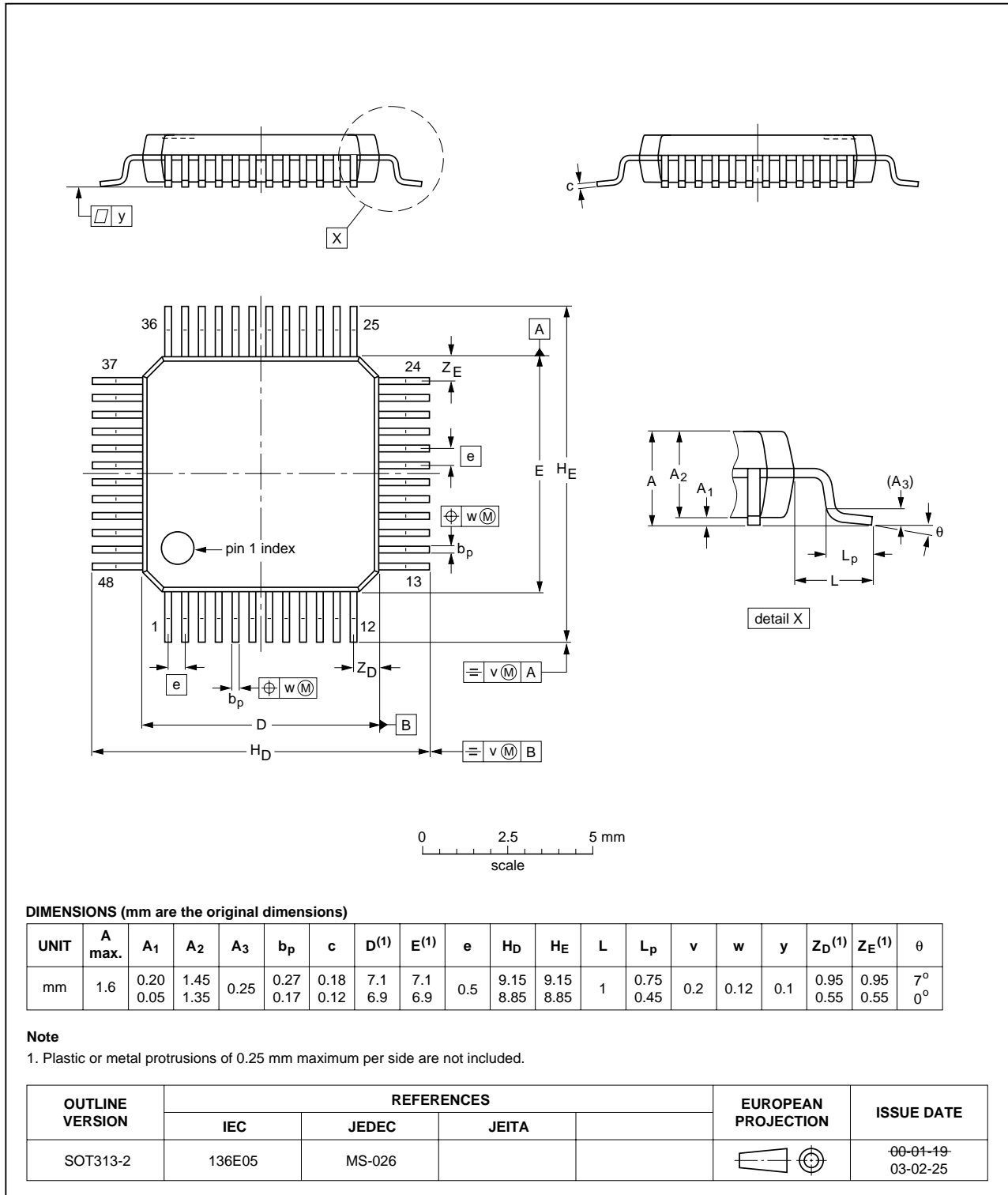

Fig 12. Package outline SOT313-2 (LQFP48)

## 14. Soldering

### 14.1 Introduction to soldering surface mount packages

This text gives a very brief insight to a complex technology. A more in-depth account of soldering ICs can be found in our *Data Handbook IC26; Integrated Circuit Packages* (document order number 9398 652 90011).

There is no soldering method that is ideal for all surface mount IC packages. Wave soldering can still be used for certain surface mount ICs, but it is not suitable for fine pitch SMDs. In these situations reflow soldering is recommended.

### 14.2 Reflow soldering

Reflow soldering requires solder paste (a suspension of fine solder particles, flux and binding agent) to be applied to the printed-circuit board by screen printing, stencilling or pressure-syringe dispensing before package placement. Driven by legislation and environmental forces the worldwide use of lead-free solder pastes is increasing.

Several methods exist for reflowing; for example, convection or convection/infrared heating in a conveyor type oven. Throughput times (preheating, soldering and cooling) vary between 100 seconds and 200 seconds depending on heating method.

Typical reflow peak temperatures range from 215 °C to 260 °C depending on solder paste material. The top-surface temperature of the packages should preferably be kept:

- below 225 °C (SnPb process) or below 245 °C (Pb-free process)
  - for all BGA, HTSSON..T and SSOP..T packages
  - for packages with a thickness  $\geq 2.5$  mm
  - for packages with a thickness  $< 2.5$  mm and a volume  $\geq 350$  mm<sup>3</sup> so called thick/large packages.
- below 240 °C (SnPb process) or below 260 °C (Pb-free process) for packages with a thickness  $< 2.5$  mm and a volume  $< 350$  mm<sup>3</sup> so called small/thin packages.

Moisture sensitivity precautions, as indicated on packing, must be respected at all times.

### 14.3 Wave soldering

Conventional single wave soldering is not recommended for surface mount devices (SMDs) or printed-circuit boards with a high component density, as solder bridging and non-wetting can present major problems.

To overcome these problems the double-wave soldering method was specifically developed.

If wave soldering is used the following conditions must be observed for optimal results:

- Use a double-wave soldering method comprising a turbulent wave with high upward pressure followed by a smooth laminar wave.
- For packages with leads on two sides and a pitch (e):
  - larger than or equal to 1.27 mm, the footprint longitudinal axis is **preferred** to be parallel to the transport direction of the printed-circuit board;

- smaller than 1.27 mm, the footprint longitudinal axis **must** be parallel to the transport direction of the printed-circuit board.

The footprint must incorporate solder thieves at the downstream end.

- For packages with leads on four sides, the footprint must be placed at a 45° angle to the transport direction of the printed-circuit board. The footprint must incorporate solder thieves downstream and at the side corners.

During placement and before soldering, the package must be fixed with a droplet of adhesive. The adhesive can be applied by screen printing, pin transfer or syringe dispensing. The package can be soldered after the adhesive is cured.

Typical dwell time of the leads in the wave ranges from 3 seconds to 4 seconds at 250 °C or 265 °C, depending on solder material applied, SnPb or Pb-free respectively.

A mildly-activated flux will eliminate the need for removal of corrosive residues in most applications.

#### 14.4 Manual soldering

Fix the component by first soldering two diagonally-opposite end leads. Use a low voltage (24 V or less) soldering iron applied to the flat part of the lead. Contact time must be limited to 10 seconds at up to 300 °C.

When using a dedicated tool, all other leads can be soldered in one operation within 2 seconds to 5 seconds between 270 °C and 320 °C.

#### 14.5 Package related soldering information

Table 7. Suitability of surface mount IC packages for wave and reflow soldering methods

Package <sup>[1]</sup>	Soldering method	
	Wave	Reflow <sup>[2]</sup>
BGA, HTSSON..T <sup>[3]</sup> , LBGA, LFBGA, SQFP, SSOP..T <sup>[3]</sup> , TFBGA, VFBGA, XSON	not suitable	suitable
DHVQFN, HBCC, HBGA, HLQFP, HSO, HSOP, HSQFP, HSSON, HTQFP, HTSSOP, HVQFN, HVSON, SMS	not suitable <sup>[4]</sup>	suitable
PLCC <sup>[5]</sup> , SO, SOJ	suitable	suitable
LQFP, QFP, TQFP	not recommended <sup>[5][6]</sup>	suitable
SSOP, TSSOP, VSO, VSSOP	not recommended <sup>[7]</sup>	suitable
CWQCCN..L <sup>[8]</sup> , PMFP <sup>[9]</sup> , WQCCN..L <sup>[8]</sup>	not suitable	not suitable

[1] For more detailed information on the BGA packages refer to the *(LF)BGA Application Note (AN01026)*; order a copy from your Philips Semiconductors sales office.

[2] All surface mount (SMD) packages are moisture sensitive. Depending upon the moisture content, the maximum temperature (with respect to time) and body size of the package, there is a risk that internal or external package cracks may occur due to vaporization of the moisture in them (the so called popcorn effect). For details, refer to the Drypack information in the *Data Handbook IC26; Integrated Circuit Packages; Section: Packing Methods*.

[3] These transparent plastic packages are extremely sensitive to reflow soldering conditions and must on no account be processed through more than one soldering cycle or subjected to infrared reflow soldering with peak temperature exceeding 217 °C ± 10 °C measured in the atmosphere of the reflow oven. The package body peak temperature must be kept as low as possible.

- [4] These packages are not suitable for wave soldering. On versions with the heatsink on the bottom side, the solder cannot penetrate between the printed-circuit board and the heatsink. On versions with the heatsink on the top side, the solder might be deposited on the heatsink surface.
- [5] If wave soldering is considered, then the package must be placed at a 45° angle to the solder wave direction. The package footprint must incorporate solder thieves downstream and at the side corners.
- [6] Wave soldering is suitable for LQFP, QFP and TQFP packages with a pitch (e) larger than 0.8 mm; it is definitely not suitable for packages with a pitch (e) equal to or smaller than 0.65 mm.
- [7] Wave soldering is suitable for SSOP, TSSOP, VSO and VSSOP packages with a pitch (e) equal to or larger than 0.65 mm; it is definitely not suitable for packages with a pitch (e) equal to or smaller than 0.5 mm.
- [8] Image sensor packages in principle should not be soldered. They are mounted in sockets or delivered pre-mounted on flex foil. However, the image sensor package can be mounted by the client on a flex foil by using a hot bar soldering process. The appropriate soldering profile can be provided on request.
- [9] Hot bar soldering or manual soldering is suitable for PMFP packages.

## 15. Revision history

**Table 8. Revision history**

Document ID	Release date	Data sheet status	Change notice	Supersedes
TDA8777_4	20060411	Product data sheet	-	TDA8777_3
Modifications:	<ul style="list-style-type: none"> <li>• Status changed to Product data sheet.</li> <li>• Characteristics table revised, see <a href="#">Table 6</a>.</li> </ul>			
TDA8777_3	20050815	Preliminary data sheet	-	TDA8777_2
Modifications:	<ul style="list-style-type: none"> <li>• The format of this data sheet has been redesigned to comply with the new presentation and information standard of Philips Semiconductors.</li> <li>• Status changed to Preliminary data sheet.</li> <li>• Characteristics table revised, SPDR and THD data added, see Table 6.</li> <li>• Figure 4 corrected.</li> <li>• Figure 5 through to Figure 10 added.</li> </ul>			
TDA8777_2 (9397 750 13219)	20040517	Objective specification	-	TDA8777_1
TDA8777_1 (9397 750 12054)	20040108	Objective specification	-	-



## 16. Legal information

### 16.1 Data sheet status

Document status <sup>[1][2]</sup>	Product status <sup>[3]</sup>	Definition
Objective [short] data sheet	Development	This document contains data from the objective specification for product development.
Preliminary [short] data sheet	Qualification	This document contains data from the preliminary specification.
Product [short] data sheet	Production	This document contains the product specification.

[1] Please consult the most recently issued document before initiating or completing a design.

[2] The term 'short data sheet' is explained in section "Definitions".

[3] The product status of device(s) described in this document may have changed since this document was published and may differ in case of multiple devices. The latest product status information is available on the Internet at URL <http://www.semiconductors.philips.com>.

### 16.2 Definitions

**Draft** — The document is a draft version only. The content is still under internal review and subject to formal approval, which may result in modifications or additions. Philips Semiconductors does not give any representations or warranties as to the accuracy or completeness of information included herein and shall have no liability for the consequences of use of such information.

**Short data sheet** — A short data sheet is an extract from a full data sheet with the same product type number(s) and title. A short data sheet is intended for quick reference only and should not be relied upon to contain detailed and full information. For detailed and full information see the relevant full data sheet, which is available on request via the local Philips Semiconductors sales office. In case of any inconsistency or conflict with the short data sheet, the full data sheet shall prevail.

### 16.3 Disclaimers

**General** — Information in this document is believed to be accurate and reliable. However, Philips Semiconductors does not give any representations or warranties, expressed or implied, as to the accuracy or completeness of such information and shall have no liability for the consequences of use of such information.

**Right to make changes** — Philips Semiconductors reserves the right to make changes to information published in this document, including without limitation specifications and product descriptions, at any time and without notice. This document supersedes and replaces all information supplied prior to the publication hereof.

**Suitability for use** — Philips Semiconductors products are not designed, authorized or warranted to be suitable for use in medical, military, aircraft, space or life support equipment, nor in applications where failure or

malfunction of a Philips Semiconductors product can reasonably be expected to result in personal injury, death or severe property or environmental damage. Philips Semiconductors accepts no liability for inclusion and/or use of Philips Semiconductors products in such equipment or applications and therefore such inclusion and/or use is at the customer's own risk.

**Applications** — Applications that are described herein for any of these products are for illustrative purposes only. Philips Semiconductors makes no representation or warranty that such applications will be suitable for the specified use without further testing or modification.

**Limiting values** — Stress above one or more limiting values (as defined in the Absolute Maximum Ratings System of IEC 60134) may cause permanent damage to the device. Limiting values are stress ratings only and operation of the device at these or any other conditions above those given in the Characteristics sections of this document is not implied. Exposure to limiting values for extended periods may affect device reliability.

**Terms and conditions of sale** — Philips Semiconductors products are sold subject to the general terms and conditions of commercial sale, as published at <http://www.semiconductors.philips.com/profile/terms>, including those pertaining to warranty, intellectual property rights infringement and limitation of liability, unless explicitly otherwise agreed to in writing by Philips Semiconductors. In case of any inconsistency or conflict between information in this document and such terms and conditions, the latter will prevail.

**No offer to sell or license** — Nothing in this document may be interpreted or construed as an offer to sell products that is open for acceptance or the grant, conveyance or implication of any license under any copyrights, patents or other industrial or intellectual property rights.

### 16.4 Trademarks

Notice: All referenced brands, product names, service names and trademarks are the property of their respective owners.

## 17. Contact information

For additional information, please visit: <http://www.semiconductors.philips.com>

For sales office addresses, send an email to: [sales.addresses@www.semiconductors.philips.com](mailto:sales.addresses@www.semiconductors.philips.com)

## 18. Contents

<b>1</b>	<b>General description</b> .....	<b>1</b>
<b>2</b>	<b>Features</b> .....	<b>1</b>
<b>3</b>	<b>Applications</b> .....	<b>1</b>
<b>4</b>	<b>Quick reference data</b> .....	<b>2</b>
<b>5</b>	<b>Ordering information</b> .....	<b>2</b>
<b>6</b>	<b>Block diagram</b> .....	<b>3</b>
<b>7</b>	<b>Pinning information</b> .....	<b>4</b>
7.1	Pinning .....	4
7.2	Pin description .....	4
<b>8</b>	<b>Functional description</b> .....	<b>5</b>
8.1	Voltage reference .....	5
8.2	Blanking and sync pulse insertion .....	6
<b>9</b>	<b>Limiting values</b> .....	<b>6</b>
<b>10</b>	<b>Thermal characteristics</b> .....	<b>7</b>
<b>11</b>	<b>Characteristics</b> .....	<b>7</b>
<b>12</b>	<b>Application information</b> .....	<b>10</b>
<b>13</b>	<b>Package outline</b> .....	<b>12</b>
<b>14</b>	<b>Soldering</b> .....	<b>13</b>
14.1	Introduction to soldering surface mount packages .....	13
14.2	Reflow soldering .....	13
14.3	Wave soldering .....	13
14.4	Manual soldering .....	14
14.5	Package related soldering information .....	14
<b>15</b>	<b>Revision history</b> .....	<b>16</b>
<b>16</b>	<b>Legal information</b> .....	<b>17</b>
16.1	Data sheet status .....	17
16.2	Definitions .....	17
16.3	Disclaimers .....	17
16.4	Trademarks .....	17
<b>17</b>	<b>Contact information</b> .....	<b>17</b>
<b>18</b>	<b>Contents</b> .....	<b>18</b>

Please be aware that important notices concerning this document and the product(s) described herein, have been included in section 'Legal information'.



© Koninklijke Philips Electronics N.V. 2006. All rights reserved.

For more information, please visit: <http://www.semiconductors.philips.com>.

For sales office addresses, email to: [sales.addresses@www.semiconductors.philips.com](mailto:sales.addresses@www.semiconductors.philips.com).

Date of release: 11 April 2006

Document identifier: TDA8777\_4