

GaAs Infrared Emitting Diode in Side View Package

Description

TSKS5400-FSZ is a standard GaAs infrared emitting diode in a flat sideview molded plastic package. A small recessed spherical lens provides an improved radiant intensity in a low profile case.

The diode is case compatible to the TEKS5400 photodetector, allowing the user to assemble his own optical sensor.

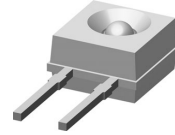

14 354

Features

- Side view package with spherical lens
- Radiation direction perpendicular to mounting direction
- Angle of half sensitivity $\phi = \pm 30^\circ$
- Peak wavelength $\lambda_p = 950 \text{ nm}$
- Case compatible with TEKS5400
- Lead-free device

Parts Table

Part	Type differentiation	Remarks
TSKS5400-FSZ	2.54 mm Pin distance (lead to lead)	Height of taping 27 mm

Absolute Maximum Ratings

$T_{amb} = 25^\circ\text{C}$, unless otherwise specified

Parameter	Test condition	Symbol	Value	Unit
Reverse voltage		V_R	6	V
Forward current		I_F	100	mA
Surge forward current	$t_p \leq 100 \mu\text{s}$	I_{FSM}	2	A
Power dissipation		P_V	170	mW
Junction temperature		T_j	100	$^\circ\text{C}$
Operating temperature range		T_{stg}	- 25 to + 85	$^\circ\text{C}$
Storage temperature range		T_{stg}	- 40 to + 100	$^\circ\text{C}$
Soldering temperature	$t \leq 5 \text{ s}$, 2 mm from body	T_{sd}	260	$^\circ\text{C}$
Thermal resistance junction/ ambient		R_{thJA}	450	k/W

Basic Characteristics

$T_{amb} = 25^\circ\text{C}$, unless otherwise specified

Parameter	Test condition	Symbol	Min	Typ.	Max	Unit
Forward voltage	$I_F = 100 \text{ mA}$, $t_p \leq 20 \text{ ms}$	V_F		1.3	1.7	V
Reverse voltage	$I_R = 10 \mu\text{A}$	V_{VR}	6			V
Junction capacitance	$V_R = 0 \text{ V}$, $f = 1 \text{ MHz}$, $E = 0$	C_j		30		pF
Radiant intensity	$I_F = 50 \text{ mA}$, $t_p \leq 20 \text{ ms}$	I_e	2		7	mW/ sr
Radiant power	$I_F = 50 \text{ mA}$, $t_p \leq 20 \text{ ms}$	ϕ_e		10		mW
Temp. coefficient of ϕ_e	$I_F = 50 \text{ mA}$	TK_{ϕ_e}		-0.8		%K

Parameter	Test condition	Symbol	Min	Typ.	Max	Unit
Angle of half sensitivity		ϕ		± 30		$^{\circ}$
Peak wavelength	$I_F = 50 \text{ mA}$	λ_p		950		nm
Spectral bandwidth	$I_F = 50 \text{ mA}$	$\Delta\lambda$		50		nm
Rise time	$I_F = 1 \text{ A}, t_p/T = 0.01, t_p \leq 10 \mu\text{s}$	t_r		400		ns
Fall time	$I_F = 1 \text{ A}, t_p/T = 0.01, t_p \leq 10 \mu\text{s}$	t_f		450		ns

Typical Characteristics ($T_{amb} = 25 \text{ }^{\circ}\text{C}$ unless otherwise specified)

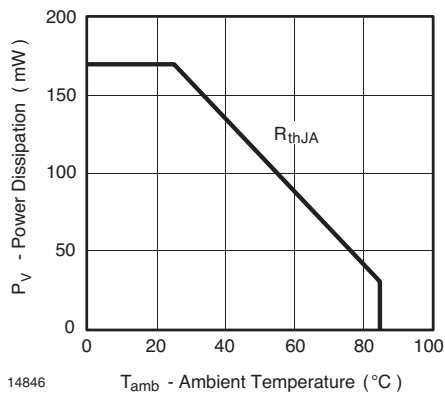

Figure 1. Power Dissipation vs. Ambient Temperature

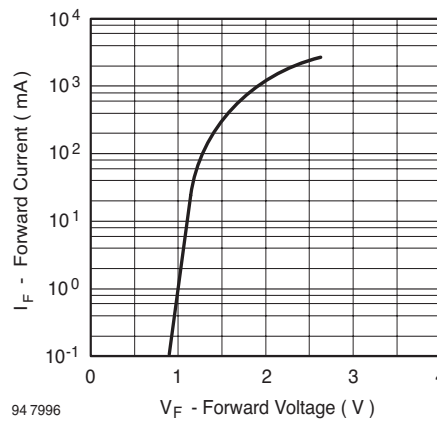

Figure 3. Forward Current vs. Forward Voltage

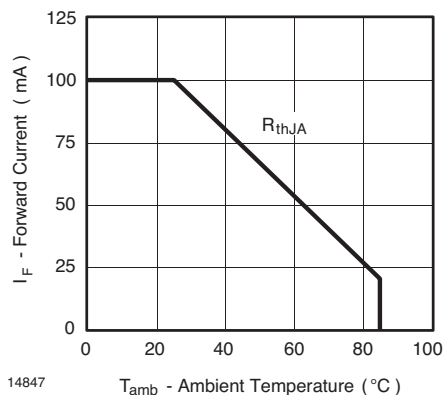

Figure 2. Forward Current vs. Ambient Temperature

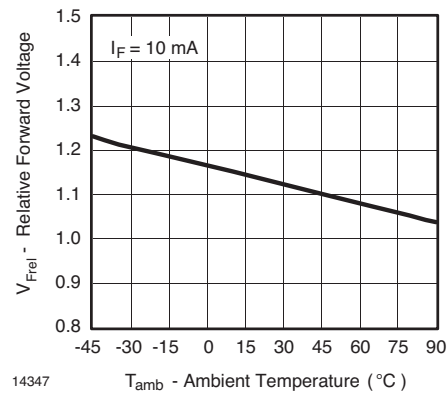

Figure 4. Forward Voltage vs. Ambient Temperature

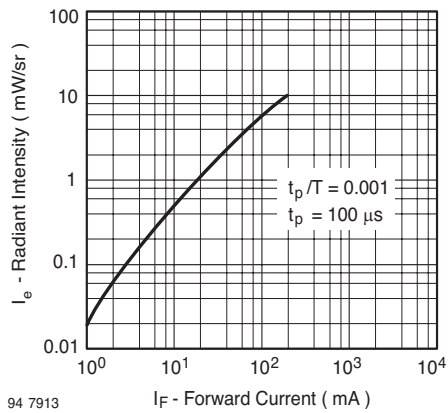

Figure 5. Radiant Intensity vs. Forward Current

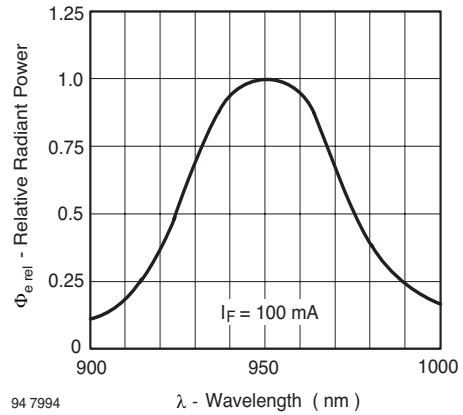

Figure 8. Relative Radiant Power vs. Wavelength

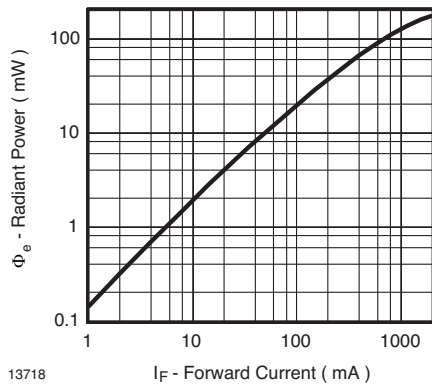

Figure 6. Radiant Power vs. Forward Current

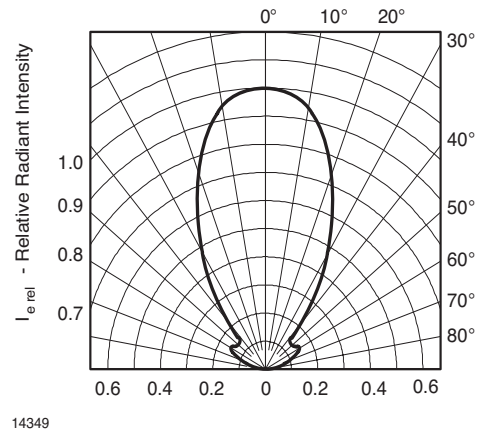

Figure 9. Relative Radiant Intensity vs. Angular Displacement

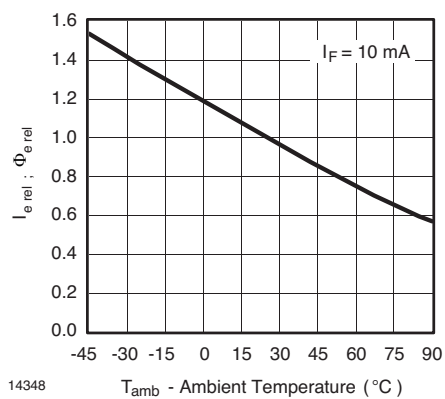
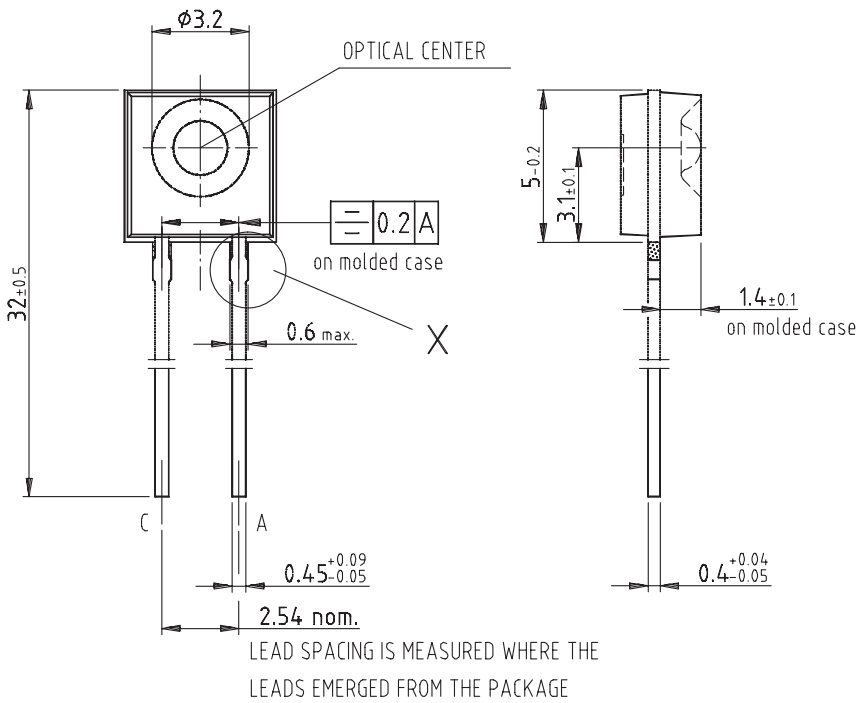
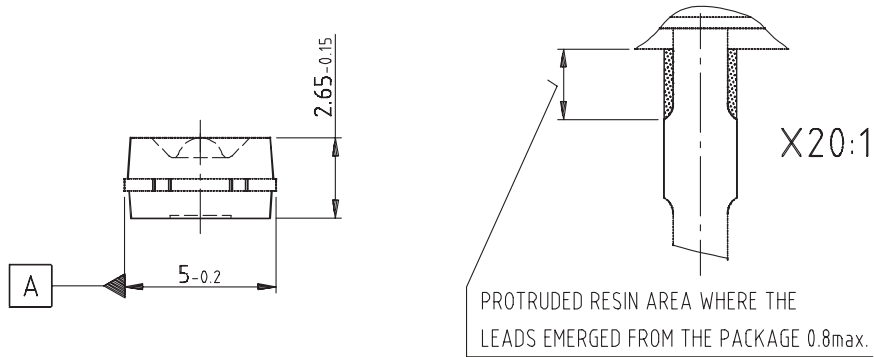

Figure 7. Relative Radiant Intensity vs. Ambient Temperature

Package Dimensions in mm



technical drawings
according to DIN
specifications

Drawing-No.: 6.544-5308.51-4

Issue: 7; 05.12.00

14345

Ozone Depleting Substances Policy Statement

It is the policy of **Vishay Semiconductor GmbH** to

1. Meet all present and future national and international statutory requirements.
2. Regularly and continuously improve the performance of our products, processes, distribution and operating systems with respect to their impact on the health and safety of our employees and the public, as well as their impact on the environment.

It is particular concern to control or eliminate releases of those substances into the atmosphere which are known as ozone depleting substances (ODSs).

The Montreal Protocol (1987) and its London Amendments (1990) intend to severely restrict the use of ODSs and forbid their use within the next ten years. Various national and international initiatives are pressing for an earlier ban on these substances.

Vishay Semiconductor GmbH has been able to use its policy of continuous improvements to eliminate the use of ODSs listed in the following documents.

1. Annex A, B and list of transitional substances of the Montreal Protocol and the London Amendments respectively
2. Class I and II ozone depleting substances in the Clean Air Act Amendments of 1990 by the Environmental Protection Agency (EPA) in the USA
3. Council Decision 88/540/EEC and 91/690/EEC Annex A, B and C (transitional substances) respectively.

Vishay Semiconductor GmbH can certify that our semiconductors are not manufactured with ozone depleting substances and do not contain such substances.

**We reserve the right to make changes to improve technical design
and may do so without further notice.**

Parameters can vary in different applications. All operating parameters must be validated for each customer application by the customer. Should the buyer use Vishay Semiconductors products for any unintended or unauthorized application, the buyer shall indemnify Vishay Semiconductors against all claims, costs, damages, and expenses, arising out of, directly or indirectly, any claim of personal damage, injury or death associated with such unintended or unauthorized use.

Vishay Semiconductor GmbH, P.O.B. 3535, D-74025 Heilbronn, Germany
Telephone: 49 (0)7131 67 2831, Fax number: 49 (0)7131 67 2423