

**Panel Controls** **BOURNS®**

- I. Product Selection Guide.....204
- II. Mounting Hardware.....206
- III. Taper Descriptions .....207
- IV. Panel Controls
  - 6mm Square .....213
  - 9mm Square .....209
  - 9mm Square with Switch.....209
  - 1/2" (12.5mm) Square.....215
  - 5/8" (16mm) Square.....218, 219, 225
  - 5/8" (16mm) Square with Switch .....221
  - 3/4" (19mm) Diameter.....228
  - 1/2" (12.7mm) Diameter.....230
- V. Potentiometers
  - Linear Motion .....208
  - Open Frame Slide.....250
  - Low Profile Open Frame Slide.....252, 254
  - Slimline.....235
  - Rotary
    - 9mm.....243, 248
    - 11mm.....244
    - 12mm.....240
    - 14mm.....246
    - 17mm.....238, 242

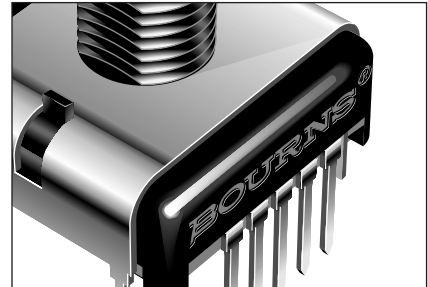

# Product Selection Guide



## Panel Controls

Model No.	Turns	Element Type	Tolerance	Tapers	Terminal Style	Package Dim.	Multi. Sec. Avail.	Switch Avail.	Page No.
51	Single	<u>Cermet</u> Conductive Plastic	$\pm 5\%$ , $\pm 10\%$ $\pm 10\%$ , $\pm 20\%$	Linear, Audio	In-line PC Pins 2.54mm Centers	1/2" (12.5mm)	Yes	No	215
53	Single	<u>Cermet</u> Conductive Plastic	$\pm 5\%$ , $\pm 10\%$ $\pm 10\%$ , $\pm 20\%$	Linear, Audio	Solder Lugs	1/2" (12.5mm)	Yes	No	215
81	Single	<u>Cermet</u> Conductive Plastic	$\pm 5\%$ , $\pm 10\%$ $\pm 10\%$ , $\pm 20\%$	Linear, Audio	PC Pins L-Pattern	5/8" (16mm)	Yes	No	218
82	Single	<u>Cermet</u> Conductive Plastic	$\pm 5\%$ , $\pm 10\%$ $\pm 10\%$ , $\pm 20\%$	Linear, Audio	J-Hooks L-Pattern	5/8" (16mm)	Yes	No	218
83	10	<u>Wirewound</u> Hybritron®	$\pm 5\%$ $\pm 10\%$	Linear	PC Pins	5/8" (16mm)	Yes	No	219
84	10	<u>Wirewound</u> Hybritron®	$\pm 5\%$ 10%	Linear	Solder Lugs	5/8" (16mm)	Yes	No	219
85	Single	Conductive Plastic <u>Cermet</u>		Linear, Audio	PC Pins L-Pattern	5/8" (16mm)	Yes	Yes	221
86	Single	Conductive Plastic <u>Cermet</u>		Linear, Audio	J-Hooks L-Pattern	5/8" (16mm)	Yes	Yes	221
91	Single	Conductive Plastic <u>Cermet</u>	$\pm 10\%$ , $\pm 20\%$ $\pm 5\%$ , $\pm 10\%$	Linear, Audio	In-line PC Pins	5/8" (16mm)	Yes (2 Max.)	No	225
93	Single	Conductive Plastic <u>Cermet</u>	$\pm 10\%$ , $\pm 20\%$ $\pm 5\%$ , $\pm 10\%$	Linear, Audio	L-Pattern PC Pins	5/8" (16mm)	Yes (2 Max.)	No	225

## Output (Taper) Descriptions – See Chart on Page 207

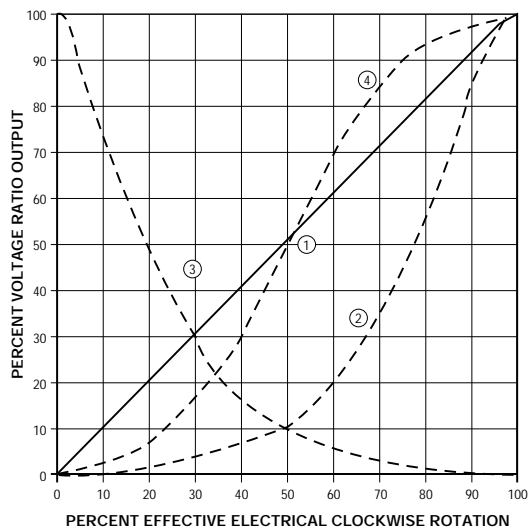

# Product Selection Guide

**BOURNS®**

## Panel Controls

Model No.	Turns	Element Type	Tolerance	Tapers	Terminal Style	Package Dim.	Multi. Sec. Avail.	Switch Avail.	Page No.
95	Single	Conductive Plastic Cermet	$\pm 10\%$ , $\pm 20\%$ $\pm 5\%$ , $\pm 10\%$	Linear, Audio	Triangle Pattern Solder Lugs	5/8" (16mm)	Yes (2 Max.)	No	225
96	Single (Sealed)	Conductive Plastic Cermet	$\pm 10\%$ , $\pm 20\%$ $\pm 5\%$ , $\pm 10\%$	Linear, Audio	In-line PC Pins (Sealed)	5/8" (16mm)	Yes (2 Max.)	No	225
3310	Single	Conductive Plastic	$\pm 20\%$	Linear	PC Board Bushing Mount	9mm	2 Max.	Yes	209
3370	Single	Conductive Plastic	$\pm 20\%$	Linear	PC Board Bushing Mount	6mm	2 Max.	No	213
3851	Single	Conductive Plastic	$\pm 10\%$ , $\pm 20\%$	Linear, Audio	PC Pins, Solder Lugs	3/4" (19mm)	No	No	228
3852	Single	Cermet	$\pm 5\%$ , $\pm 10\%$	Linear, Audio	PC Pins, Solder Lugs	3/4" (19mm)	No	No	228
3856	3-3/4	Cermet	$\pm 5\%$ , $\pm 10\%$	Linear, Audio	PC Pins, Solder Lugs	3/4" (19mm)	No	No	228
3862	Single	Cermet	$\pm 5\%$ , $\pm 10\%$	Linear, Audio	PC Pins, J-Hooks	1/2" (12.7mm)	No	No	230

## Open Frame Slide Potentiometers

Model Series	Sections	Stroke Length	Terminal Styles	Element Types/Tapers	Page No.
SS	Single	10mm 15mm 20mm 30mm	PC Pins Horizontal and Vertical	Linear, LH Audio, RH Audio, "S" Curve	232

## Slimline Potentiometers

Model Series	Tapers	Tolerance	Standard Resistance Range	Terminal Styles	Sections	Page No.
PC . . .	Linear CP CW Audio CP CCW Audio CP	$\pm 20\%$	500 $\Omega$ to 2.5 M $\Omega$	PC Pin, Solder Lug	Single	235

# Product Selection Guide



## Mounting Hardware

Panel control mounting hardware is determined by bushing style. The "X" in the bushing style column indicates what hardware is used with that bushing. Hardware indicated by shaded area is normally supplied with unit. Other hardware may be ordered separately. Hardware is bulk packaged with units.

Part Number and Description	Bushing Style												
	A/S ENS	B	C	E	J	N	R	T	U	L	W	3310/ 3370	S Mod. 50
H-36-1 Flat Washer			X	X		X		X					
H-36-2 Flat Washer	X	X			X								
H-37-1 Lockwasher			X	X		X		X					X
H-37-2 Lockwasher	X	X			X					X	X		
H-38-1 Mounting Nut			X	X		X		X				X	
H-38-2 Mounting Nut	X	X			X								
H-38-3 Lock Nut				X				X					
H-38-4 Lock Nut		X											
H-37-3 Lockwasher									X				
H-37-4 Lockwasher							X					X	
H-37-5 Lockwasher												X	
H-38-8 M-7 Mounting Nut									X				
H-38-9 M-10 Mounting Nut							X						
H-38-11 M-9 Mounting Nut										X	X		
H-38-14 M6 Mounting Nut													X

## Panel Control Options Matrix

	3851	3852	3856	3862	81/82	83/84	85/86	91-96	PC	50	EC	EN	3310/ 3370
Single Section	X	X	X	X	X	X	*	X	X	X	X	X	X
Dual Section					X	X	X*	X		X			X
Triple Section					X	Δ	Δ	Δ		X			
Quad Section					X	Δ	Δ	Δ		X			
.125" Shafts	X	X	X	X	X	X	X	X		X		X	X
.185" Shafts									X		X		
.250" Shafts	X	X	X		X	X	X	X		X	X	X	X
3mm Shaft										X			
4mm Shaft					X	X	X	X		X			
6mm Shaft					X	X	X	X	X	X	X		
Dual Concentric Shafts					X	X	Δ			Δ			
Switches							X*						X
Locking Bushing	X	X		X	X	X				Δ			

ΔConsult factory. \*Standard Construction - 1 pot section and 1 switch module.

# Product Selection Guide



## Taper Descriptions - See Graph on Page 204

Graph	Models	Taper Code	Description	Linearity	T.R. Tol.
1	81,82,85,86,91-96,3852,3856,3862,50	A	Linear — Cermet	±5% Ind.	±10%
1	81,82,85,86,91-96,3851,50	B	Linear — C.P.	±5% Ind.	±20%
2	81,82,85,86,91-96,3852,3856,50	C	CW Audio — Cermet	N/A	±10%
2	81,82,85,86,91-96,3851,50	D	CW Audio — C.P.	N/A	±20%
1	81,82,85,86,91-96,3851,50	E	Linear — C.P.	±5% Ind.	±10%
3	81,82,85,86,91-96,3852,3856,50	F	CCW Audio — Cermet	N/A	±10%
3	81,82,85,86,91-96,3851,50	G	CCW Audio — C.P.	N/A	±20%
1	81,82,85,86,91-96,3852,3856,3862	H	Linear — Cermet	±5% Ind.	±5%
1	83,84	J	Linear — Wirewound	±.25% Ind.	±10%
1	83,84	K	Linear — Hybritron® Element	±.25% Ind.	±10%
2	81,82,85,86,91-96,50	S	CW Audio — C.P.	N/A	±10%
3	81,82,85,86,91-96,50	T	CCW Audio — C.P.	N/A	±10%
4	50	Y	Dual Audio — C.P.	N/A	±20%
1	3310,3370	N/A	Linear — C.P.	±5% Ind.	±20%

## Consumer Controls / Rotaries

Series	Element Type	Tolerance	Terminal Style	Package Dimension	Shaft Type	Multi Sec. Available	Switch Available	Page Number
PDA17	Carbon	20%	Solder Lugs PC Pins	17mm	Metal	No	Yes	238
PDB12	Carbon	20%	PC Pins	12mm	Insulated	No	No	240
PDB18	Carbon	20%	Solder Lugs PC Pins	17mm	Metal	Yes (2 Max.)	No	242
PTV09	Carbon	20%	PC Pins	9mm	Insulated	No	No	243
PTV111 PTT111	Carbon	20%	PC Pins	11mm	Insulated	No	No	244
PTV142	Carbon	20%	PC Pins	14mm	Insulated	Dual-Sec. Potentiom.	No	246
PTD90 PTR90	Carbon	20%	PC Pins	9mm	Metal	Yes (6 Max.)	Yes	248

## Consumer Controls / Sliders

Series	Element Type	Tolerance	Body Type	Terminal Style	Lever Type	Travel in mm	Multi Sec. Available	Page Number
PDV	Carbon	20%	Open Frame	PC Pins	Insulated	10, 15, 20, 30	Yes (2 Max.)	250
PTA	Carbon	20%	Enclosed Body	PC Pins	Metal & Insulated	15, 20, 30 45, 60	Yes (2 Max.)	252
PTB	Carbon	20%	Enclosed Body	PC Pins	Metal	45, 60, 100	Yes (2 Max.)	254

Tapers: Audio and Linear (other std. taper on request)

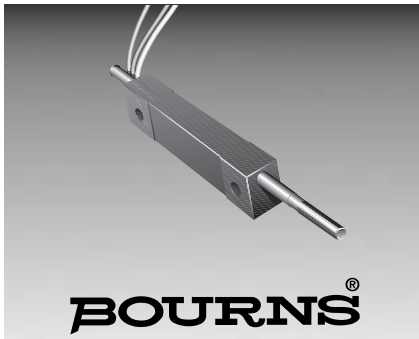

## Features

- Compact
- Lightweight
- Long life
- Infinite resolution
- Free shaft rotation
- AC or DC
- Shaft options available
- Flexible wire leads
- Economical

# 3048 Linear Motion Potentiometer

## Specifications\*

Standard Electrical Travel  
 .....0.2, 0.3, 0.4, 0.5 in.  
 (5.08, 7.62, 10.16, 12.70mm)

Standard Resistances  
 .....1K ohms to 1 megohm ( $\pm 20\%$ )

Independent Linearity ..... $\pm 5\%$

Resolution .....Infinite

Power Rating @ 70°C (158°F)  
 Range 2, 3 .....0.12 watt  
 Range 4, 5 .....0.25 watt

Operating Temperature Range  
 .....-55°C to +125°C

Temperature Coefficient ....1000 PPM/°C

Insulation Resistance.....50 megohms  
 @ 500 VDC

Backlash .....Negligible

Shaft Actuating Force .....4 oz. max.  
 @ 70°F

Life .....500,000 cycles

Shock .....50G for 6msec

Vibration .....20G, 20-20,000 Hz

Marking .....Manufacturer's trademark,  
 resistance code, wiring diagram,  
 date code, manufacturer's model  
 number and style

Specifications are typical. Contact factory for special requirements.  
 \*Specifications applicable from 5% to 95% of electrical travel.

## How to Order

Model 3048 L - 2 - 502

Style \_\_\_\_\_

Range (Travel) \_\_\_\_\_  
 2 = 0.2" (5.08mm)  
 3 = 0.3" (7.62mm)  
 4 = 0.4" (10.16mm)  
 5 = 0.5" (12.70mm)

Resistance Value \_\_\_\_\_

## Standard Resistance Table

Resistance (Ohms)	Resistance Code
1,000	102
2,500	252
5,000	502
10,000	103
20,000	203
50,000	503
100,000	104
200,000	204
500,000	504
1,000,000	105

## Product Dimensions

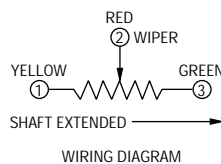
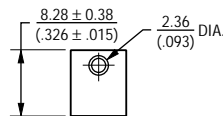
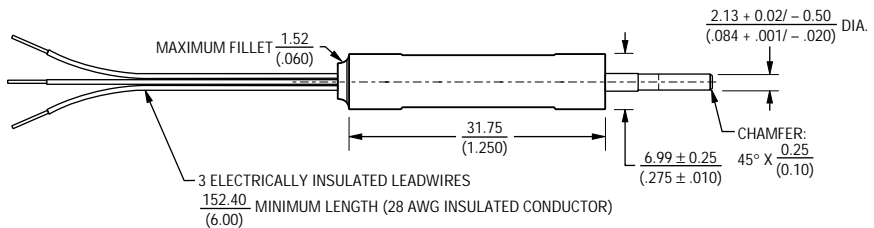
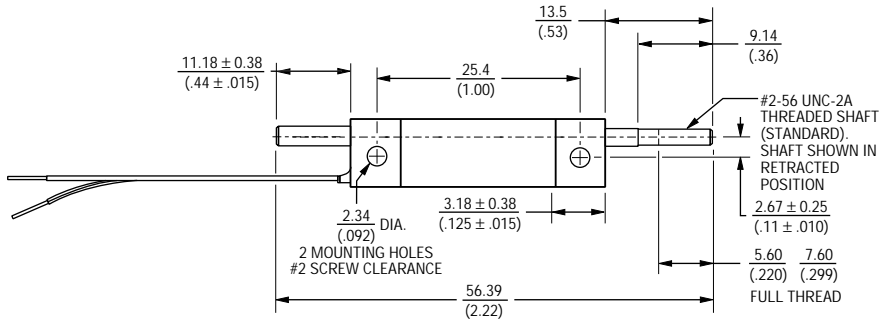

TOLERANCES:  $\pm \frac{.010}{(0.25)}$  EXCEPT WHERE NOTED

DIMENSIONS ARE:  $\frac{\text{METRIC}}{\text{(INCHES)}}$

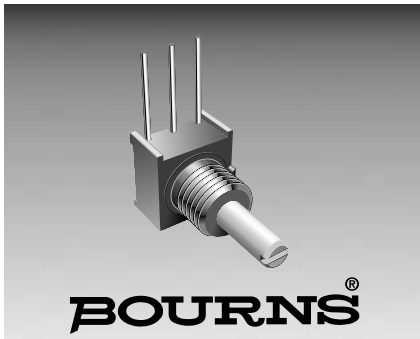

## Features

- Conductive plastic
- Linear and audio tapers
- PC board and bushing mount
- Plastic bushing and plastic shaft
- Withstands typical industrial washing processes

- Compact package saves board and panel space

# 3310 - 9mm Square Sealed Panel Control

## Electrical Characteristics

Standard Resistance Range - Linear .....	1K ohms to 1 megohm
Total Resistance Tolerance - Linear Tapers .....	±20%
Independent Linearity .....	±5%
Absolute Minimum Resistance .....	2 ohms maximum
Effective Electrical Angle .....	270° ±15°
Contact Resistance Variation .....	.1% or 1 ohm (whichever is greater)
Dielectric Withstanding Voltage	
Sea Level .....	900 VAC minimum
70,000 Feet .....	350 VAC minimum
Insulation Resistance .....	1,000 megohms minimum
Power Rating @ 70°C (Derate to 0 at 125°C - Voltage Limited By Power Dissipation or 200 VAC, Whichever is Less) .....	0.25 watts

## Environmental Characteristics

Operating Temperature .....	+1°C to +125°C
Storage Temperature .....	-55°C to +125°C
TCR (Over Storage Temperature Range) .....	±1,000ppm/°C
Vibration .....	.30G
Total Resistance Shift .....	±1% maximum
Voltage Ratio Shift .....	±1% maximum
Shock .....	100G
Total Resistance Shift .....	±1% maximum
Voltage Ratio Shift .....	±1% maximum
Load Life (1,000 Hours) .....	±10% TRS maximum
Rotational Life-No Load (50,000 Cycles) .....	±5% TRS maximum
CRV .....	±3% or 3 ohms (whichever is greater)
Moisture Resistance .....	±10% TRS

## Mechanical Characteristics

Stop Strength .....	5.65 Ncm
Mechanical Angle .....	300° nominal
Torque - Running .....	3.53 Ncm
Weight .....	4.5 grams
Flammability .....	Conforms to UL94V-0
Terminals .....	Solderable pins
Marking .....	Manufacturer's symbol and model number, product code, terminal style, date code and resistance code

## Standard Resistance Table

Resistance (Ohms)	Resistance Code
<b>1,000</b>	<b>102</b>
<b>2,000</b>	<b>202</b>
<b>5,000</b>	<b>502</b>
<b>10,000</b>	<b>103</b>
<b>20,000</b>	<b>203</b>
50,000	503
100,000	104
200,000	204
500,000	504
1,000,000	105

Popular values listed in boldface. Consult factory for special resistances.

## Part Numbering System

Model Number Designator	3310 Y - 0 0 1 - 103
3310 = 9mm Panel Control	
Terminal Style Designator	Y
Single Cup:	
C = In-line Straight Terminals Side Exit 2.54 mm centers	
R = In-line Terminals Rear Exit 2.54 mm centers	
P = 5.08mm x 2.54mm Triangular Pattern Rear Exit	
Y = 5.08mm x 5.08mm Triangular Pattern Rear Exit	
Dual Cup (Pot/Pot or Pot/Switch):	
H = Dual In-line Straight Terminals Rear Exit 2.54 mm centers	
Shaft End Designator	0 0
0 = Shaft End Slotted	
1 = Shaft End Flatted	
Shaft Length Designator	1
0 = 12.7mm FMS Long Plastic Shaft	
1 = 19.05mm FMS Long Plastic Shaft (Use with bushing version only)	
2 = 5.59mm FMS Long Plastic Shaft (Bushingless version only)	
Bushing Designator	103
Pot (or Pot/Pot):	
1 = 6.35mm x 6.35mm Plastic	
2 = 6.35mm x 6.35mm Ni Plated Brass	
5 = Bushingless (Board Level Control)	
Pot/Switch Bushing Designator (use with "H" terminal style only):	
3 = 6.35mm x 6.35mm Plastic	
4 = 6.35mm x 6.35mm Ni Plated Brass	
6 = Bushingless (Board Level) Pot/Switch	
Resistance Code	103
(1st 2 digits are significant, 3rd digit is number of 0s to follow)	

# 3310 - Dimensions and Tolerances



## COMMON DIMENSIONS

### 3310-001 Plastic Bushing Slotted Shaft

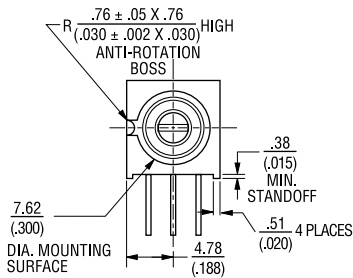
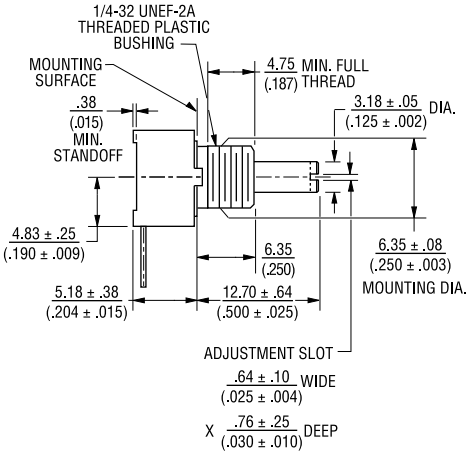
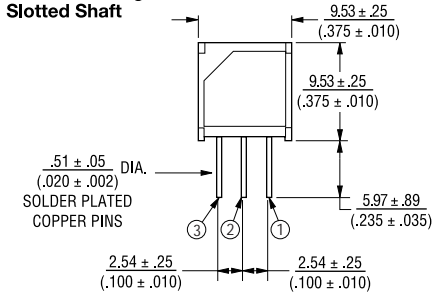

### 3310C-001

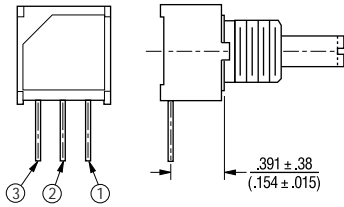

### 3310P-001

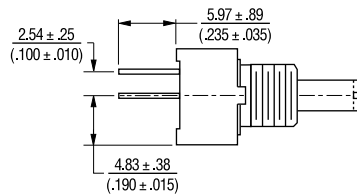
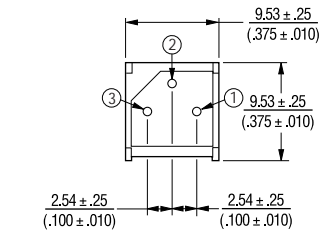

### 3310R-001

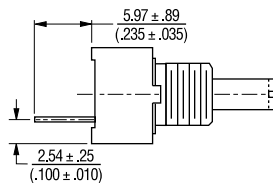
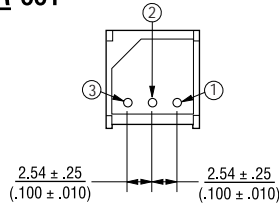

### 3310Y-001

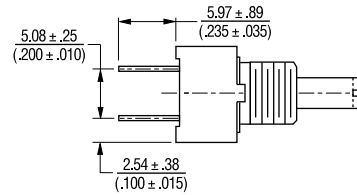
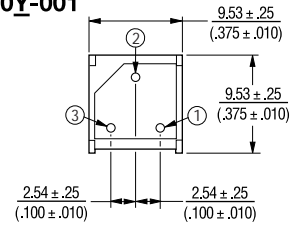

## COMMON DIMENSIONS 3310C-101 Plastic Flatted Shaft

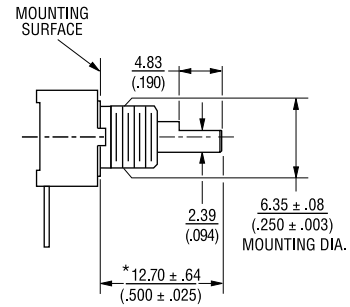

\*FMS = From Mounting Surface

DIMENSIONS ARE: METRIC / (INCHES)



# 3310 - Dimensions and Tolerances



## COMMON DIMENSIONS 3310-002 Metal Bushing

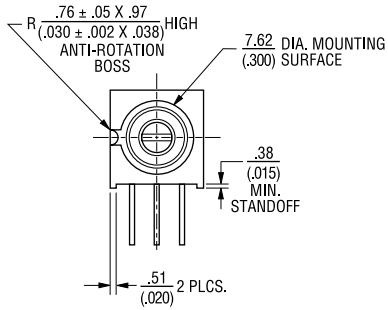
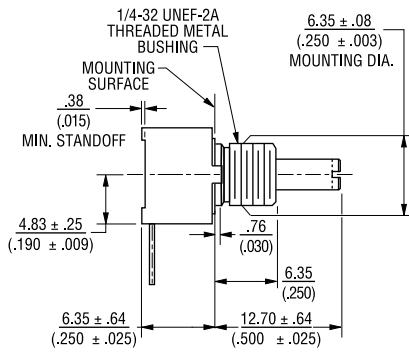

## 3310P-005\* Bushingsless

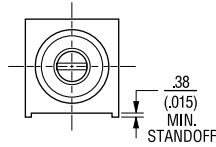
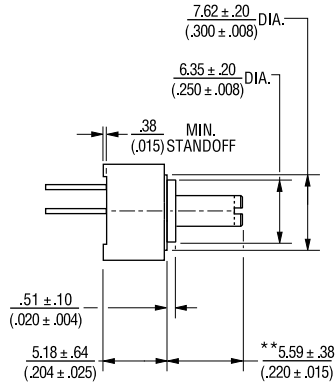

## 3310C-002

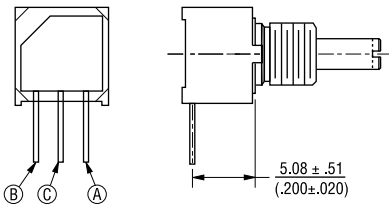

DIMENSIONS ARE:  $\frac{\text{METRIC}}{\text{(INCHES)}}$

NOTE: \*Also available in "Y" terminal style  
 \*\*Only recommended shaft length  
 for bushingsless version

Specifications are subject to change without notice.

# 3310 - Dimensions and Tolerances



## Common Dimensions 3310H-003 Pot/Switch Dual Cup Plastic Bushing

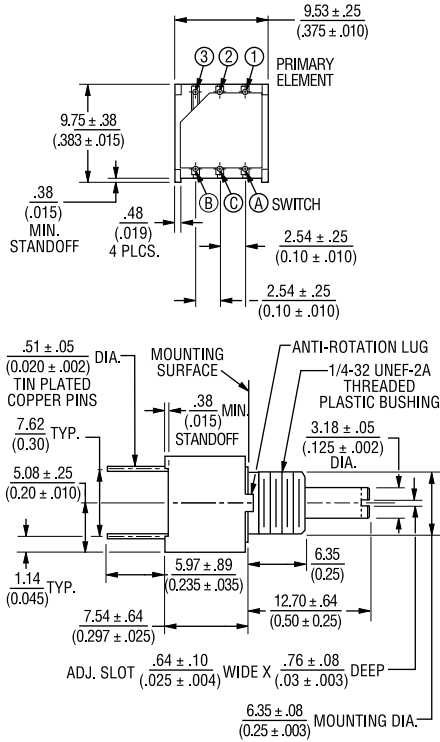

## 3310H-005 Pot/Pot Dual Cup, Bushless

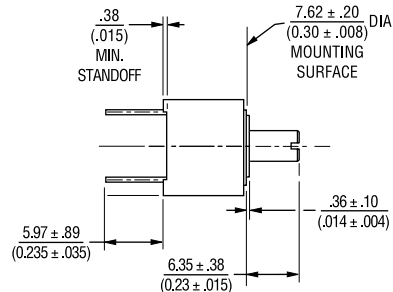
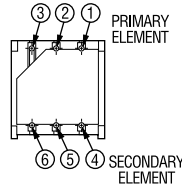

## 3310H-002 Pot/Pot Dual Cup, Metal Bushing

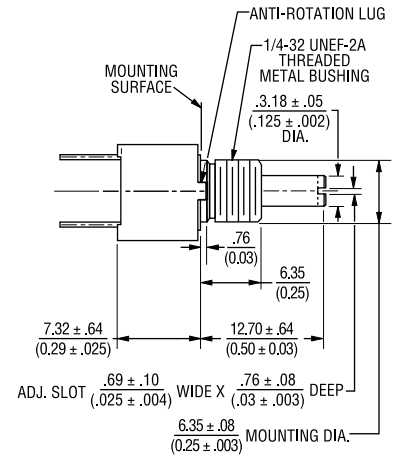
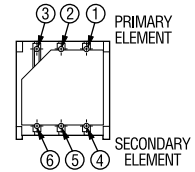

## Pot/Pot Dual Cup

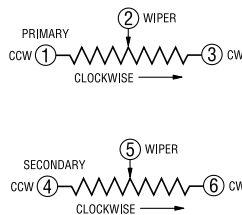

## Pot/Switch Dual Cup

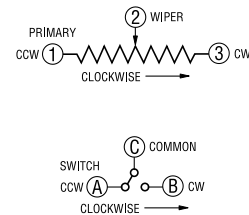

DIMENSIONS ARE: METRIC  
(INCHES)

## Pot Single Cup

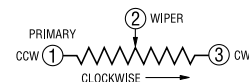

NOTE: \*Also available in "Y" terminal style  
\*\*Only recommended shaft length  
for bushless version

Specifications are subject to change without notice.

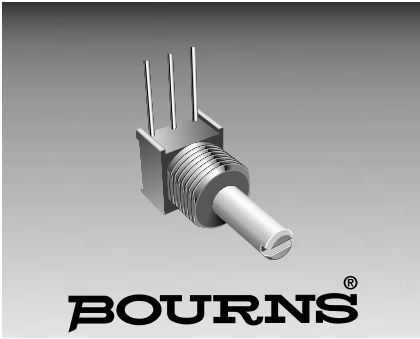

## Features

- Conductive plastic
- Linear and audio tapers
- PC board and bushing mount
- Plastic bushing and plastic shaft
- Withstands typical industrial washing processes

# 3370 - 6mm Square Sealed Panel Control

### Electrical Characteristics

Standard Resistance Range	1K ohms to 1 megohm
Linear	±20%
Total Resistance Tolerance	±5%
Linear Tapers	±20%
Independent Linearity	±5%
Absolute Minimum Resistance	2 ohms maximum
Effective Electrical Angle	240° nominal
Contact Resistance Variation	1 ohm or 1% (whichever is greater)
Dielectric Withstanding Voltage	
Sea Level	900 VAC minimum
70,000 Feet	350 VAC minimum
Insulation Resistance	1,000 megohms minimum
Power Rating @ 70°C (Derate to 0 at 125°C - Voltage Limited By Power Dissipation or 200 VAC, Whichever is Less)	.25 watts

### Environmental Characteristics

Storage Temperature	-55°C to +125°C
TCR (Over Storage Temperature Range)	±1,000ppm/°C
Vibration	30G
Total Resistance Shift	±2% maximum
Voltage Ratio Shift	±2% maximum
Shock	100G
Total Resistance Shift	±2% maximum
Voltage Ratio Shift	±2% maximum
Load Life (1,000 Hours)	±10% TRS maximum
Rotational Life-No Load (50,000 Cycles)	±5% TRS maximum
CRV	3 ohms or 3% whichever is greater
Moisture Resistance	±10% TRS

### Mechanical Characteristics

Stop Strength	5.65 Ncm
Mechanical Angle	310° nominal
Torque	
Starting	1.41 Ncm Max.
Weight	4.5 grams
Flammability	Conforms to UL94V-0
Epoxy	Conforms to UL94V-1
Terminals	Solderable pins
Marking	Manufacturer's symbol and model number, product code, terminal style, date code and resistance code

### Standard Resistance Table

Resistance (Ohms)	Resistance Code
<b>1,000</b>	<b>102</b>
<b>2,000</b>	<b>202</b>
<b>5,000</b>	<b>502</b>
<b>10,000</b>	<b>103</b>
<b>20,000</b>	<b>203</b>
50,000	503
100,000	104
200,000	204
500,000	504
1,000,000	105

Popular values listed in boldface. Consult factory for special resistances.

### Part Numbering System

Model Number Designator	<b>3370</b>	Y	-	0	0	1	-	<b>103</b>
3370 = 6mm Panel Control								
Terminal Style Designator								
Single Cup:								
C = In-line Straight Terminals Side Exit								
P = 5.08mm x 2.54mm Triangular Pattern Rear Exit								
Y = 5.08mm x 5.08mm Triangular Pattern Rear Exit								
Shaft End Designator								
0 = Shaft End Slotted								
Shaft Length Designator								
0 = 12.7mm FMS Long Plastic Shaft								
Bushing Designator								
1 = 6.35mm x 6.35mm Plastic								
Resistance Code								
(1st 2 digits are significant, 3rd digit is number of 0s to follow)								

# 3370 - Dimensions and Tolerances



## COMMON DIMENSIONS 3370C

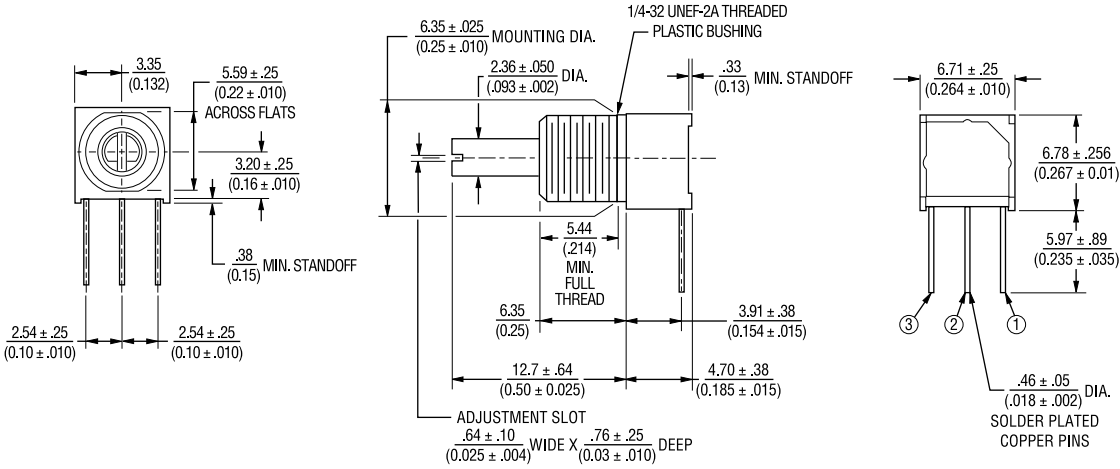

## 3370P

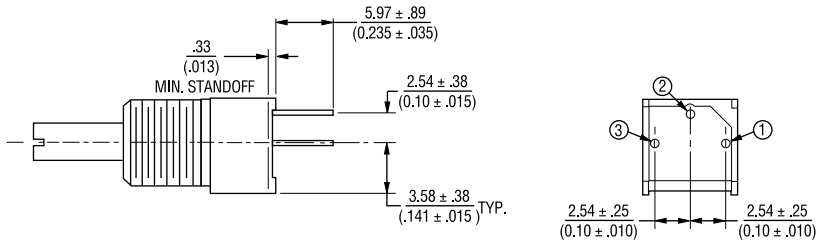

## 3370Y

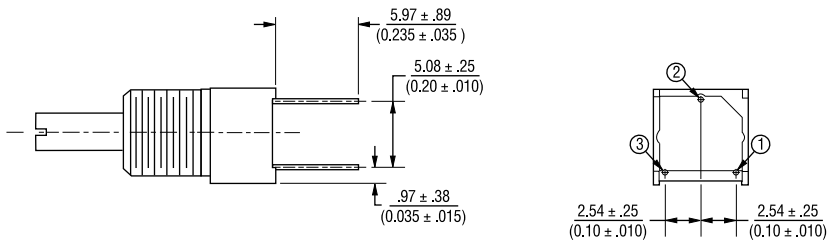

DIMENSIONS ARE:  $\frac{\text{METRIC}}{\text{(INCHES)}}$

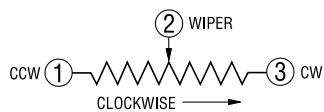

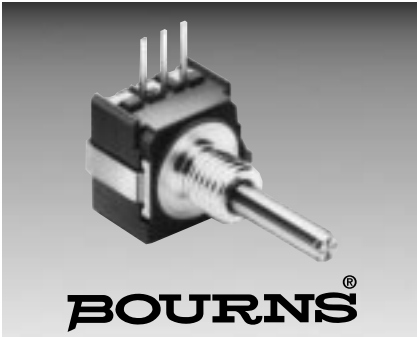

## Features

- Conductive plastic or cermet
- Linear and audio tapers
- PC board and bushing mount
- Gangable
- Metal bushing and shaft
- Sealed for board washing

## 50 Series - Sealed 1/2" (12.5mm) Square Control

Electrical Characteristics <sup>1</sup>	Conductive Plastic	Cermet
Standard Resistance Range		
Linear.....	1K ohms to 1 megohm.....	150 ohms to 1 megohm
Audio.....	1K ohms to 1 megohm.....	1K ohms to 1 megohm
Total Resistance Tolerance		
Linear Tapers.....	±10% OR ±20%.....	±10% OR ±5%
Audio Tapers.....	±10% OR ±20%.....	±10%
Independent Linearity.....	±5%.....	±5%
Absolute Minimum Resistance.....	2 ohms maximum.....	2 ohms maximum
Effective Electrical Angle.....	270°±5°.....	270°±5°
Contact Resistance Variation.....	2.0%.....	2.0%
Dielectric Withstanding Voltage		
Sea Level.....	1,500 VAC minimum.....	1,500 VAC minimum
70,000.....	500 VAC minimum.....	500 VAC minimum
Insulation Resistance.....	1,000 megohms minimum.....	1,000 megohms minimum
Power Rating At 70°C (Derate To 0 At 125°C) (Voltage Limited By Power Dissipation or 350 VAC, Whichever Is Less)		
Linear Tapers.....	0.5 watt.....	1.0 watt
Audio Tapers.....	0.25 watt.....	0.5 watt
Tracking (Multiple Sections).....	3 db.....	3 db

## Environmental Characteristics<sup>1</sup>

Operating Temperature.....	+1°C to +125°C.....	+1°C to +125°C
Storage Temperature.....	-55°C to +125°C.....	-55°C to +125°C
TCR (Over Storage Temperature Range).....	±1,000ppm/°C.....	±150ppm/°C
Vibration (Single Section).....	15G.....	15G
Total Resistance Shift.....	±2% maximum.....	±2% maximum
Voltage Ratio Shift.....	±5% maximum.....	±5% maximum
Shock (Single Section).....	30G.....	30G
Total Resistance Shift.....	+2% maximum.....	±2% maximum
Voltage Ratio Shift.....	±5% maximum.....	±5% maximum
Load Life (1,000 Hours).....	±10% TRS maximum.....	±5% TRS maximum
Rotational Life-No Load (50,000 Cycles) <sup>2</sup> .....	±10% TRS maximum.....	±10% TRS maximum
CRV @ 25,000 Cycles.....	±2%.....	±4%
Moisture Resistance.....	±10% TRS.....	±5% TRS

## Mechanical Characteristics

Stop Strength.....	5 in-lb.....	5 in-lb.
Mechanical Angle.....	290° ±5°.....	290° ±5°
Torque		
Running (Single Section).....	0.2 to 2.0 oz.-in. (0.15 to 1.4Ncm).....	0.2 to 2.0 oz.-in. (0.15 to 1.4 Ncm)
Running (Dual or Triple Section).....	0.5 to 2.5 oz.-in. (0.35 to 1.8 Ncm).....	0.5 to 2.5 oz.-in. (0.35 to 1.8 Ncm)
Starting (All Sections).....	Running torque +0.5 oz.-in. (+0.35 Ncm) maximum.....	Running torque +0.5 oz.-in. (+0.35 Ncm) maximum
Weight (Single Section).....	5.5 grams.....	5.5 grams
Each Additional Section.....	3.0 grams.....	3.0 grams
Terminals.....	PC pin or solder lug.....	PC pin or solder lug
Marking.....	Manufacturer's symbol and part number, date code and resistance value	

<sup>1</sup>At room ambient: +25°C nominal and 50% relative humidity nominal, except as noted.

<sup>2</sup>Conductive Plastic, 25,000 cycles for cermet elements.

# 50 Series - Dimensions and Tolerances



## PACKAGE DIMENSIONS

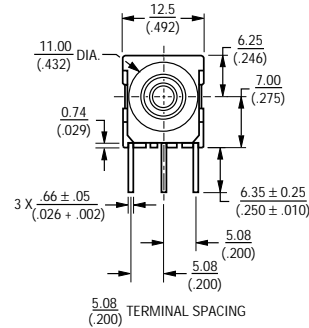
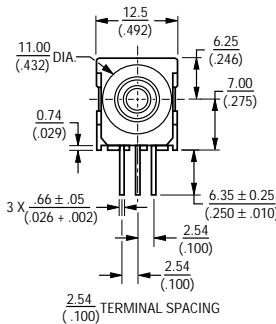
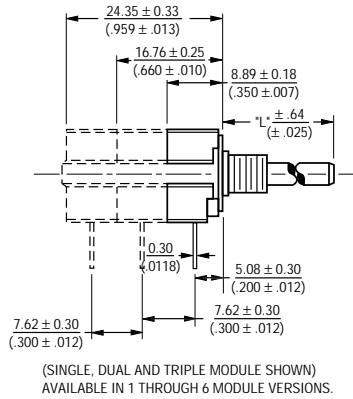

## PACKAGE DIMENSIONS PCB MOUNTING BRACKET

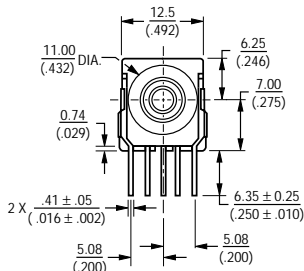
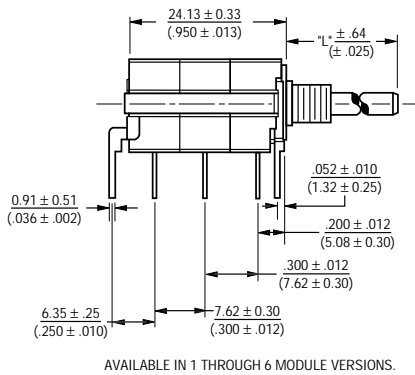

## SOLDER LUG TERMINALS

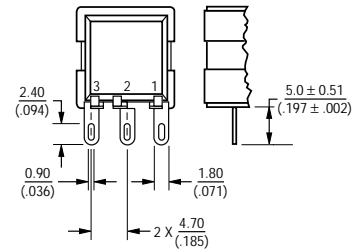

## ELECTRICAL SCHEMATIC

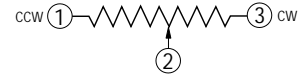

## ANTI-ROTATION LUG (Style "A", 90° CW Shown)

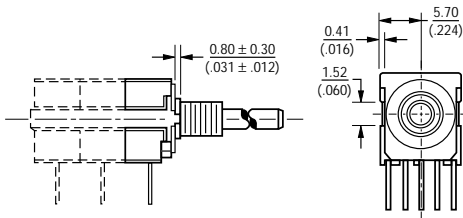

## SHAFT FLAT ORIENTATION

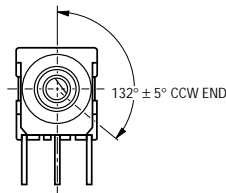

## SUGGESTED PANEL LAYOUTS

The Model 50 can be used with either of the two panel layouts shown below.

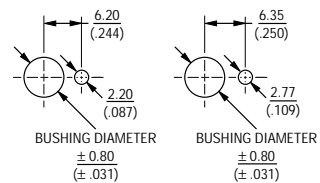

FOR TOLERANCES SHOWN: .XX = ± .25 (.010)  
.XXX = ± .13 (.005)  
SHAFT DIMENSIONS ± .80 (.132)

DIMENSIONS ARE: METRIC (INCHES)

# 50 Series- Dimensions and Tolerances



## Shaft/Bushing Styles

**A Style Bushing**

STD. LENGTH 'L'
.500 (12.7)
.625 (15.88)
.750 (19.05)
.875 (22.23)
1.000 (25.4)

6.35 (250) SHAFT 9.53 (375) BUSHING  
3/8-32UNEF-2A

**C Style Bushing**

STD. LENGTH 'L'
.375 (9.53)
.500 (12.7)
.625 (15.88)
.750 (19.05)
.875 (22.23)
1.000 (25.4)

3.18 (125) SHAFT 6.35 (250) BUSHING  
1/4-32UNEF-2A

**A Style Bushing - Flatted Shaft**

STD. LENGTH 'L'
.625 (15.88)
.750 (19.05)
.875 (22.23)
1.000 (25.4)

6.35 (250) SHAFT 9.53 (375) BUSHING  
3/8-32UNEF-2A

**F Style Bushing**

STD. LENGTH 'L'
.625 (15.88)
.750 (19.05)
.875 (22.23)
1.000 (25.4)

.125 (3.18) SHAFT .250 (6.35) BUSHING  
1/4-32UNEF-2A

**S Style Bushing**

STD. LENGTH 'L'
.394 (10.0)
.512 (13.0)
.630 (16.0)
.866 (22.0)
.984 (25.0)

3.0 (118) SHAFT 6.0 (2.36) BUSHING  
M6 X .075-6g

**U Style Bushing**

STD. LENGTH 'L'
.394 (10.0)
.512 (13.0)
.630 (16.0)
.866 (22.0)
.984 (25.0)

4.0 (157) SHAFT 7.0 (2.75) BUSHING  
M7 X .075-6g

**R Style Bushing**

STD. LENGTH 'L'
.512 (13.0)
.630 (16.0)
.866 (22.0)
.984 (25.0)

6.0 (236) SHAFT 10.0 (3.94) BUSHING  
M10 X 0.75-6g

## How To Order

51 A A D - B 28 - A 15

**MOUNTING BRACKET/ ANTI-ROTATION LUG**

Code	Description
A	AR Lug 90°CW
D	No AR Lug or Bracket

ELEMENT TAPER TYPE/TOLERANCE		RESISTANCE (CODE)	
Code	Description	VALUE IN OHMS	
(A)	Linear Cermet ±10%	(10) — 1K	(18) — 50K
(B)	Linear C-P ±20%	(13) — 5K	(20) — 100K
(D)	CW Audio C-P ±20%	(15) — 10K	

**# SECTIONS/DETENTS**

Code	Description
A	Single No Detent
B	Double No Detent

**BUSHING CONFIGURATION**

Code	Description
A	3/8"D x 3/8"L
C	1/4"D x 1/4"L
R	10mmD x 9.5mmL
S	6mmD x 8mmL
U	7mmD x 8mmL

SHAFT LENGTH (FMS)		AVAILABLE ONLY IN BUSHING
Code	Description	Code
24	3/4"	A, C, F
28	7/8"	A, C, F
Metric		
16	16mm	R, S, U, T
25	25mm	R, S, U, T

**MODEL**

Code	Description
51	PC Pins (.100" centers)
53	Solder Lugs

SHAFT TYPE		AVAILABLE ONLY IN	
		BUSHINGS	LENGTHS
Code	Description	Code	Description
B	Single Slotted 1/4"D	A	24,28
E	Single Slotted 1/8"D	C, F	24,28
R	Single Slotted 6mmD	R	25
T	Single Slotted 4mmD	U	25
U	Single Slotted 3mmD	S	16

(Recommended standard P/N's)  
For Other Options Contact the Factory  
Boldface listings are in stock and readily available through distribution.

DIMENSIONS ARE: METRIC  
(INCHES)

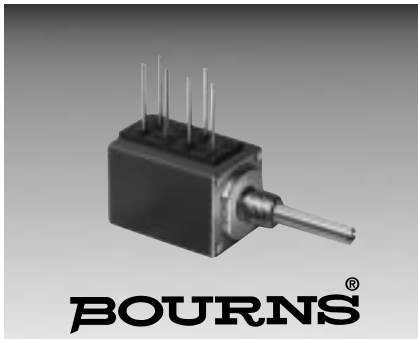

## Features

- Metal shaft and bushing
- Consistent, smooth quality feel
- Up to 4 sections available

# 81/82 - 5/8" Square Single-Turn Conductive Plastic

Initial Electrical Characteristics <sup>1</sup>	Conductive Plastic Element	Cermet Element
Standard Resistance Range		
Linear Tapers (A, B, E, & H)	(B & E) 1K ohms to 1 megohm	(A & H) 50 ohms to 1 megohm
Audio Tapers (C, D, F, G, S, & T)	(D, G, S, & T) 1K ohms to 1 megohm	(C & F) 1K ohms to 1 megohm
Resistance Tolerance	(B, D & G tapers) ±20% (E, S, & T tapers) ±10%	(A, C, & F tapers) ±10% (H taper) ±5%
Independent Linearity	(B & E tapers) ±5%	(A & H tapers) ±5%
Absolute Minimum Resistance	2 ohms maximum	2 ohms maximum
Continuity	Maintained for full mechanical angle	Maintained for full mechanical angle
Effective Electrical Angle	240° ±5%	240° ±6°
Contact Resistance Variation	±1%	±1% or 3 ohms (whichever is greater)
Theoretical Resolution	Essentially infinite	Essentially infinite
Dielectric Withstanding Voltage	MIL-STD-202, Method 301	MIL-STD-202, Method 301
Sea Level	1,500 VAC minimum	1,500 VAC minimum
70,000 Feet	500 VAC minimum	500 VAC minimum
Insulation Resistance (500 VDC)	1,000 megohms minimum	1,000 megohms minimum
Power Rating At 70°C (Voltage Limited By Power Dissipation or 350 VAC, Whichever Is Less)		
+70°C Single Section Assembly	(B & E tapers) 0.5 watt (D, G, S & T tapers) 0.25 watt	(A & H tapers) 2 watts (C & F tapers) 1 watt
+70°C Multiple Section Assembly	(B & E tapers) 0.5 watt/section (D, G, S & T tapers) 0.25 watt/section	(A & H tapers) 1 watt/section (C & F tapers) 0.5 watt/section
+125°C	0 watt	0 watt
Roll-on/Roll-off	(B & E tapers) 0.25% maximum (D & S tapers) 0.1% maximum CCW end (G & T tapers) 0.1% maximum CW end (D & S tapers) 0.5% maximum CW end (G & T tapers) 0.5% maximum CCW end	(A & H tapers) 0.5% maximum (C taper) 0.1% maximum CCW end (F taper) 0.1% maximum CW end (C taper) 1.0% maximum CW end (F taper) 1.0% maximum CCW end

Environmental Characteristics <sup>1</sup>	Conductive Plastic Element	Cermet Element
Operating Temperature	+1°C to +125°C	+1°C to +125°C
Storage Temperature Range	-55°C to +125°C	-55°C to +125°C
Temperature Coefficient		
Over Storage Temperature Range	±1,000PPM/°C	±150PPM/°C
Vibration (Single Section)	15G	15G
Voltage Ratio Shift	±5% maximum	±5% maximum
Total Resistance Shift	±2% maximum	±2% maximum
Shock (Single Section)	30G	30G
Voltage Ratio Shift	±5% maximum	±5% maximum
Total Resistance Shift	±2% maximum	±2% maximum
Load Life	1,000 hours	1,000 hours
Total Resistance Shift	±10% maximum	±5% maximum
Rotational Life (No Load)	100,000 cycles	100,000 cycles
Total Resistance Shift	(B & E tapers) 10 ohms or ±12% maximum (whichever is greater) (D, G, S & T tapers) ±20% maximum	10 ohms or ±10% maximum (whichever is greater)
Moisture Resistance	MIL-STD-202, Method 103, Condition B	MIL-STD-202, Method 103, Condition B
Total Resistance Shift	(B & E tapers) ±10% maximum (D, G, S & T tapers) ±20% maximum	±5% maximum (all tapers)
Insulation Resistance (500 VDC)	100 megohms minimum	100 megohms minimum

Mechanical Characteristics <sup>1</sup>	Conductive Plastic Element	Cermet Element
Running Torque (Non-Locking Bushings)		
Single Section	0.2 to 1.5 oz.-in. (0.14 to 1.06 Ncm)	0.2 to 1.5 oz.-in. (0.14 to 1.06 Ncm)
Dual Section	0.2 to 1.5 oz.-in. (0.14 to 1.06 Ncm)	0.2 to 1.5 oz.-in. (0.14 to 1.06 Ncm)
Triple Section	0.5 to 2.0 oz.-in. (0.35 to 1.41 Ncm)	0.5 to 2.0 oz.-in. (0.35 to 1.41 Ncm)
Quadruple Section	0.5 to 2.0 oz.-in. (0.35 to 1.41 Ncm)	0.5 to 2.0 oz.-in. (0.35 to 1.41 Ncm)
Running Torque (Locking Bushings)	0.2 to 4.0 oz.-in. (0.14 to 2.82 Ncm)	0.2 to 4.0 oz.-in. (0.14 to 2.82 Ncm)
Shaft Locking Torque with Locknut @ 10 in.-lb. (B & E Bushings)	20 oz-in.	20 oz-in.
Stop Strength	1/4" (6.35mm) and 1/8" (3.18mm) shafts - 4 in.-lb. (45.19 Ncm) min. 7/8" (19.81mm) shaft -2 in.-lb. (22.6 Ncm) min.	1/4" (6.35mm) and 1/8" (3.18mm) shafts - 4 in.-lb. (45.19 Ncm) min. 7/8" (19.81mm) shaft -2 in.-lb. (22.6 Ncm) min.
Mechanical Angle	300° ±5°	300° ±5°
Weight (Single Section)	21 grams maximum	21 grams maximum
Each Additional Section	6 grams maximum	6 grams maximum
Terminals	Printed circuit terminals or J-Hooks	Printed circuit terminals or J-Hooks
Marking	Manufacturer's trademark, wiring diagram, date code and resistance, manufacturer's part number	

For dimensional drawings see page 222.  
For ordering information see page 224.

NOTE: Model 81/82 performance specifications do not apply to units subjected to printed circuit board cleaning procedures.

<sup>1</sup>At room ambient: +25°C nominal and 50% relative humidity nominal, except as noted.

Specifications are subject to change without notice.



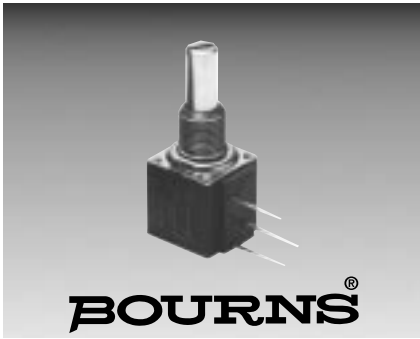

**BOURNS®**

## Features

- Compatible with other members of the Model 80 Series
- The only 10-turn precision potentiometer in a modular panel control package
- Up to 3 sections available

## 83/84 - 5/8" Square 10-Turn

### Initial Electrical Characteristics<sup>1</sup>

	Wirewound Element (J Taper)	Hybriton® Element (K Taper)
Standard Resistance Range	200 to 100K ohms	1K to 100K ohms
Resistance Tolerance	±5%	±10%
Independent Linearity	±0.25%	±0.25%
Effective Electrical Angle	3600° +10°, -0°	3600° +10°, -0°
Minimum Resistance (J Taper)	1.0 ohm or 0.1% (whichever is greater)	-
End Voltage (K Taper)	-	0.2% of applied voltage
Noise (J Taper)	100 ohms ENR maximum	-
Output Smoothness (K Taper)	-	0.15% maximum
Dielectric Withstanding Voltage	MIL-STD-202, Method 301	MIL-STD-202, Method 301
Sea Level	1,500 VAC minimum	1,500 VAC minimum
Insulation Resistance (500 VDC)	1,000 megohms minimum	1,000 megohms minimum
Power Rating (Voltage Limited By Power Dissipation or 316 VAC, Whichever Is Less)		
+70°C	1 watt	1 watts
+125°C	0 watt	0 watt
Theoretical Resolution	See table	Essentially infinite

### Environmental Characteristics<sup>1</sup>

Operating Temperature	+1°C to +125°C	+1°C to +125°C
Storage Temperature Range	-55°C to +125°C	-55°C to +125°C
Temperature Coefficient		
Over Storage Temperature Range	±50PPM/°C	±100PPM/°C
Vibration	15G	15G
Wiper Bounce	0.1 millisecond maximum	0.1 millisecond maximum
Shock	50G	50G
Wiper Bounce	0.1 millisecond maximum	0.1 millisecond maximum
Load Life	1,000 hours	1,000 hours
Total Resistance Shift	±2% maximum	±5% maximum
Rotational Life (No Load)	1,000,000 shaft revolutions	4,000,000 shaft revolutions
Total Resistance Shift	±5% maximum	±5% maximum
Moisture Resistance	MIL-STD-202, Method 103, Condition B	MIL-STD-202, Method 103, Condition B
Total Resistance Shift	±2% maximum	±5% maximum
Insulation Resistance (500 VDC)	100 megohms minimum	100 megohms minimum

### Mechanical Characteristics<sup>1</sup>

Mechanical Angle	3600° +15°, -0°	3600° +15°, -0°
Shaft Runout	0.006 in. (0.15mm) T.I.R.	0.006 in. (0.15mm) T.I.R.
Shaft End Play	0.014 in. (0.36mm) T.I.R.	0.014 in. (0.36mm) T.I.R.
Shaft Radial Play	0.005 in. (0.13mm) T.I.R.	0.005 in. (0.13mm) T.I.R.
Stop Strength	48.0 oz.-in. (33.90 Ncm) minimum	48.0 oz.-in. (33.90 Ncm) minimum
Running Torque (1 or 2 Section)	0.25 to 2.0 oz.-in. (0.18 to 1.41 Ncm)	0.25 to 2.0 oz.-in. (0.18 to 1.41 Ncm)
Weight	Approximately 0.75 oz.-in. (0.53 Ncm)	Approximately 0.75 oz.-in. (0.53 Ncm)
Terminals	Printed circuit terminals or solder lugs	Printed circuit terminals or solder lugs
Marking	Manufacturer's trademark, wiring diagram, date code and resistance, manufacturer's part number	Manufacturer's trademark, wiring diagram, date code and resistance, manufacturer's part number

### Wirewound Resolution Table

Resistance (Ohms)	Resolution (Nom.) (%)
200	.048
500	.037
1K	.032
2K	.031
5K	.023
10K	.020
20K	.015
50K	.012
100K	.010

For dimensional drawings see page 220 and 223.  
For ordering information see page 2221

<sup>4</sup>NOTE: MODEL 83/84 PERFORMANCE SPECIFICATIONS DO NOT APPLY TO UNITS SUBJECTED TO PRINTED CIRCUIT BOARD CLEANING PROCEDURES.

<sup>1</sup>AT ROOM AMBIENT: +25°C NOMINAL AND 50% RELATIVE HUMIDITY NOMINAL, EXCEPT AS NOTED.

Specifications are subject to change without notice.

### Dimensional Drawings

Dual Section Model 84 Solder Lugs

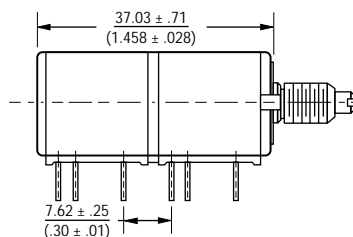

Note: The Models 83/84 dimensions for dual section assembly are for either single or dual concentric shaft styles.

Dual Section Model 83 PC Pins

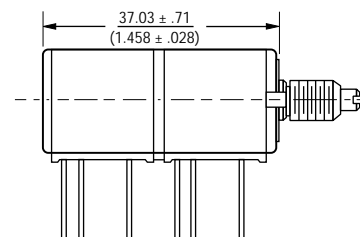

7.62 ± .25 (0.30 ± .01)

DIMENSIONS ARE:  $\frac{\text{METRIC}}{\text{(INCHES)}}$

# 83/84 - Dimensions and Tolerances



## PC Pin Model 83

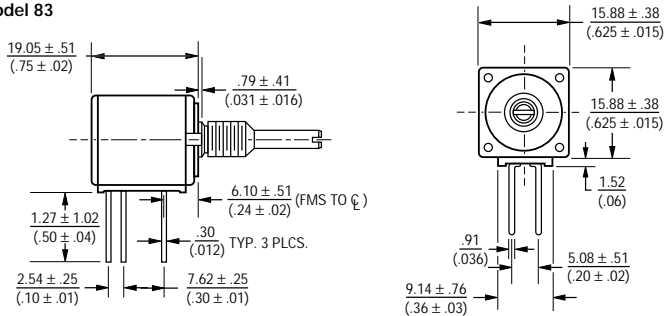

## Solder Lug Model 84

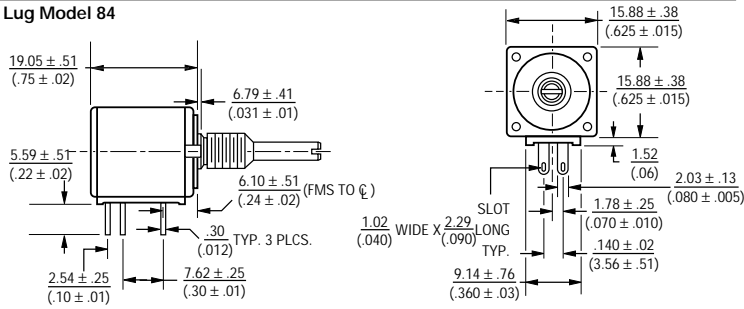

## "C" Bushing 1/4" (6.35mm) Dia. Plain - Single Shaft

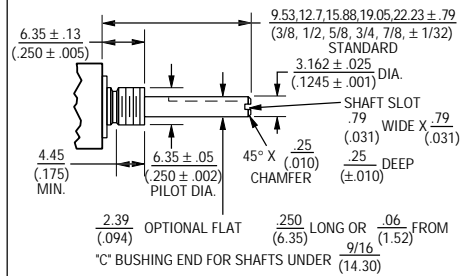

## "E" Bushing 1/4" (6.35mm) Dia. Locking - Single Shaft

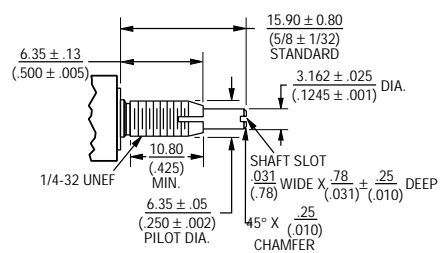

## "A" Bushing 3/8" (9.53mm) Dia. Plain - Single Shaft

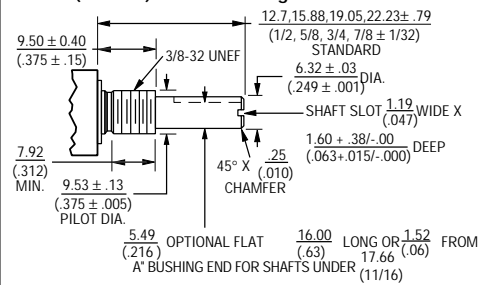

## "A" Bushing 3/8" (9.53mm) Dia. Plain - Concentric Shaft

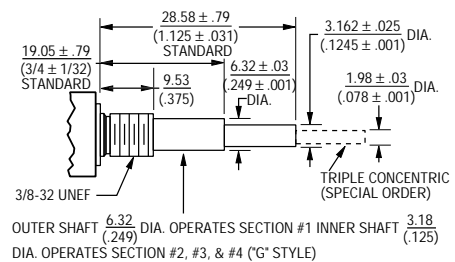

## "B" Bushing 3/8" (9.53mm) Dia. Plain - Single Shaft

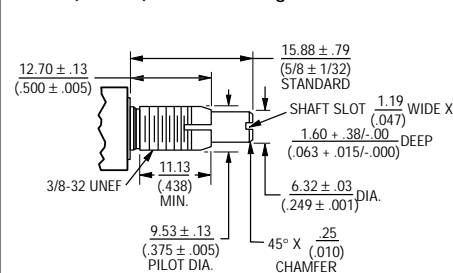

## "C" Bushing 1/4" (6.35mm) Dia. Plain - Concentric Shaft

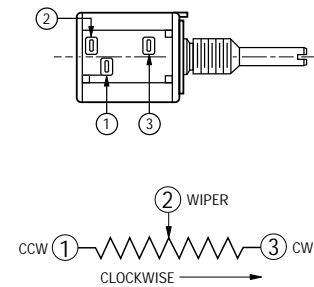
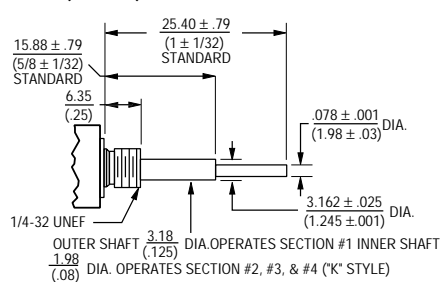

## Shaft Flat Orientation

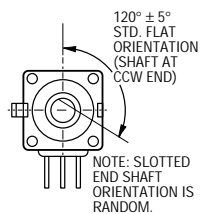

## Locating Lug Options - All Model 80 Series

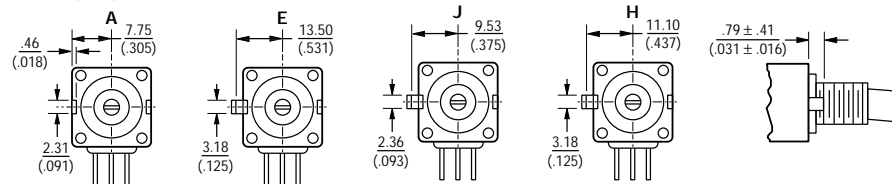

NOTE: "D" OPTION - NO A/R LUG. OTHER LOCATING LUG OPTIONS AVAILABLE. FOR DETAILS CONSULT FACTORY.

TOLERANCES EXCEPT AS SHOWN: DECIMALS .XXX ± .127 (.005), .XX ± .38 (.015), ANGLE ± 5°, FRACTIONS ± 1/64

DIMENSIONS ARE: METRIC (INCHES)

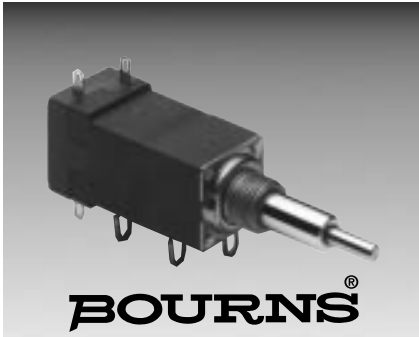

## Features

- Designed for “on-off” function control
- Positive action, “non-tease” detent
- Low actuation torque

## 85/86 - 5/8" Square Single-Turn Rotary Switch

### Initial Electrical Characteristics<sup>1</sup>

Contacts:	
DPST.....	N.O./N.O., N.C./N.C. or N.O./N.C.
DPDT.....	2 N.O./N.C. (break before make)
Power Rating (Resistive Load):	
DPST.....	2A @ 125 volts RMS-60 Hz or 2A @ 28 VDC, 1A@ 250 volts RMS-60 Hz
DPDT.....	1A @ 125 volts RMS-60 Hz or 1A @ 28 VDC
Contact Resistance (.1VDC-10mA).....	10 milliohms nominal
Contact Bounce.....	.5 milliseconds maximum
Dielectric Withstanding Voltage.....MIL-STD-202, Method 301	
Sea Level.....	1500 VAC minimum
Insulation Resistance.....	1000 megohms minimum

### Environmental Characteristics<sup>1</sup>

Operating Temperature Range.....	0°C to +70°C
Storage Temperature Range.....	-65° to +125°C
Vibration (Dual Section).....8G	
Contact Resistance.....	10 milliohms maximum
Contact Bounce.....	0.1 millisecond maximum
Shock (Dual Section).....20G	
Contact Resistance.....	10 milliohms maximum
Contact Bounce.....	0.1 millisecond maximum
Rotational Life.....	25,000 cycles
Switch Actuating Torque (50% Duty cycle @ Rated Power Load).....	2 to 7 oz.-in. (1.41 to 4.94 Ncm)
Contact Resistance.....	100 milliohms maximum
Moisture Resistance.....MIL-STD-202, Method 106, Condition B	
Contact Resistance (0.1VDC-10mA).....	10 milliohms maximum
Insulation Resistance (After 24 Hours @ Room Temperature) (500 VDC).....	100 megohms minimum
Switch Housing Material.....	High temperature, flame retardant, thermosetting plastic

### Mechanical Characteristics<sup>1</sup>

Actuating Torque (Each Section, Switch Module Only).....	.5 to 15 oz.-in. (3.53 to 10.6 Ncm)
Running Torque (Out of Detent, 2-4 Module Assembly).....	.03 to 2 oz.-in. (0.21 to 1.41 Ncm)
Detent.....	CW or CCW standard
Actuation Angle.....	.25°
Contact Materials.....Fine silver with gold overlay	
Terminal Styles.....Solder lug only	
Standard Orientation.....	In-line with control terminals
Optional.....	Rotated 90° CCW from standard
Terminal Strength (Before and After Soldering Heat Exposure).....	2 lbs. (0.9 Kg) minimum

NOTE: MODEL 85/86 PERFORMANCE SPECIFICATIONS DO NOT APPLY TO UNITS SUBJECTED TO PRINTED CIRCUIT BOARD CLEANING PROCEDURES.

<sup>1</sup>AT ROOM AMBIENT: +25°C NOMINAL AND 50% RELATIVE HUMIDITY NOMINAL, EXCEPT AS NOTED.

For Dimensional Drawings See Page 223.  
For Ordering Information See Page 224.

# Model 81, 82 - Dimensions and Tolerances

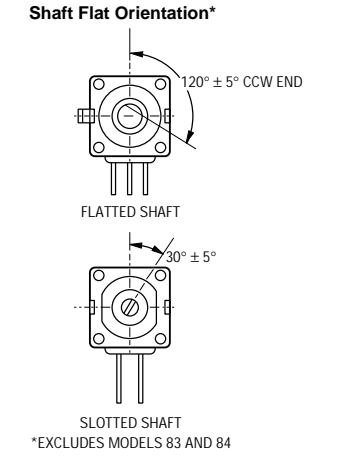
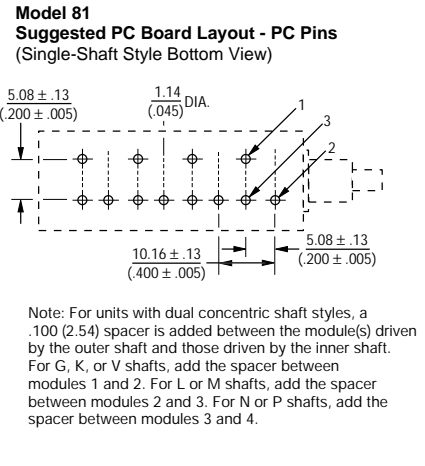
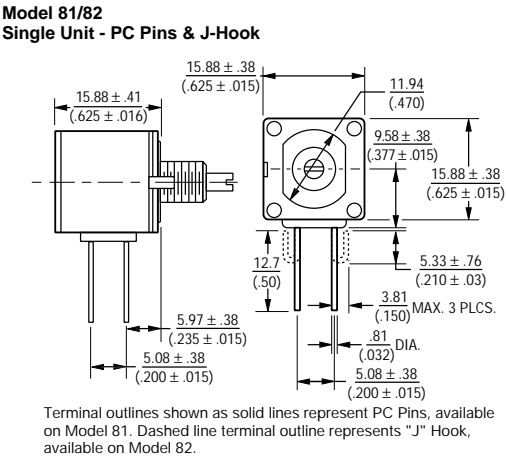
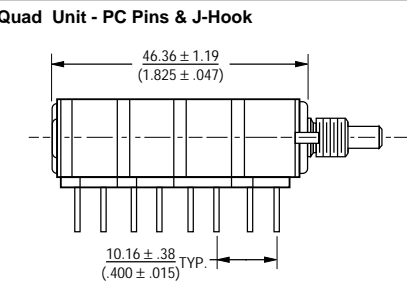
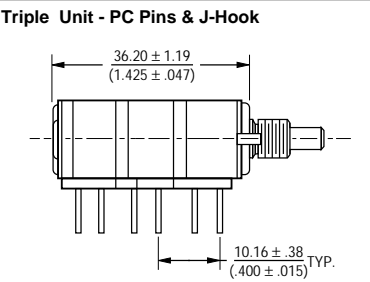
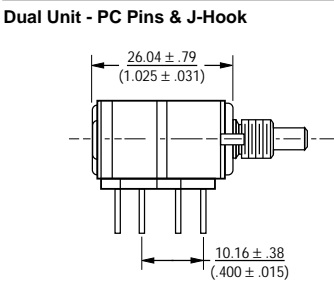
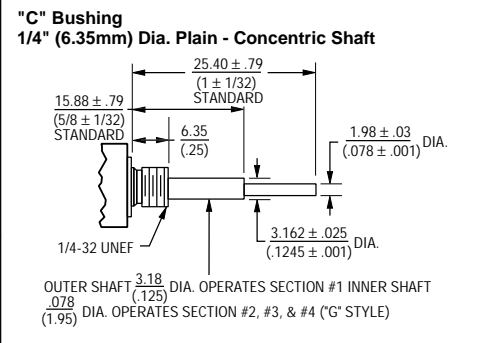
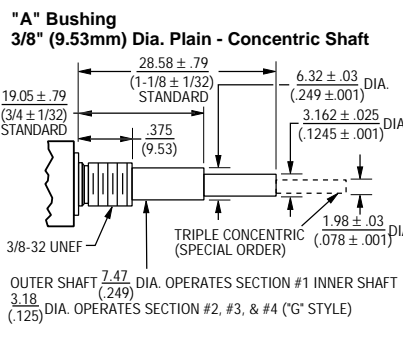
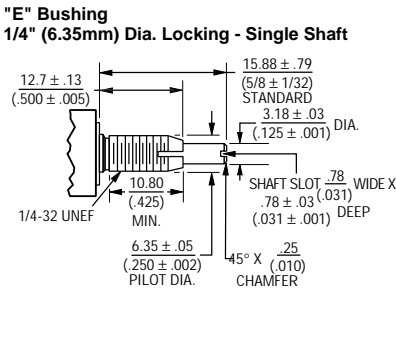
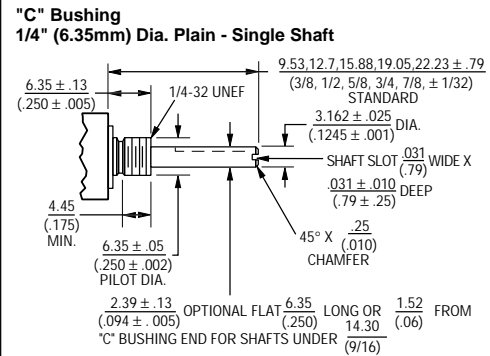
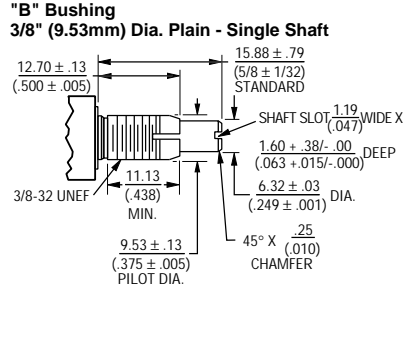
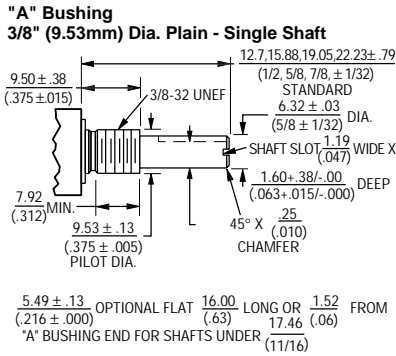

DIMENSIONS ARE: METRIC / (INCHES)

Specifications are subject to change without notice.

# Model 83, 84, 85, 86 - Dimensions and Tolerances



## Solder Lug Model 84

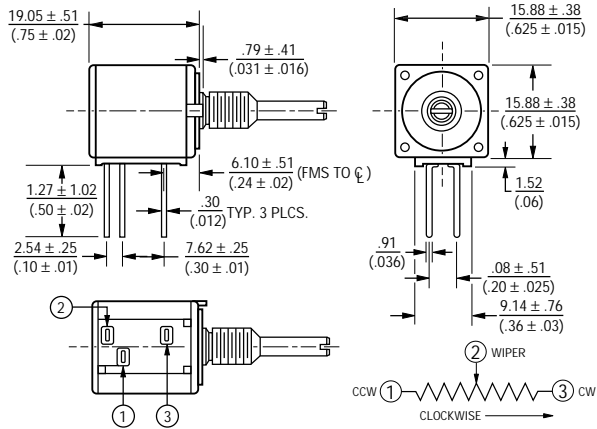

## Solder Lug Model 84

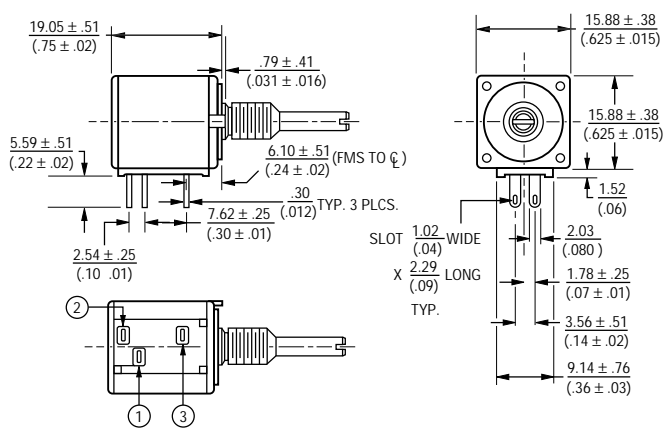

## Primary Potentiometer Module Model 85/86

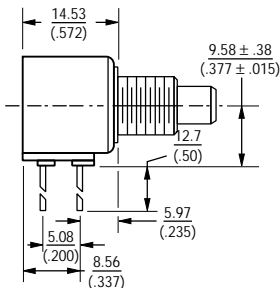

## Secondary Potentiometer Module Model 85/86

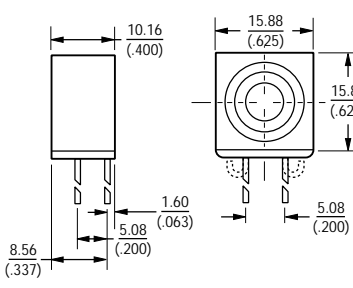

## Dual Section Model 83 PC Pins

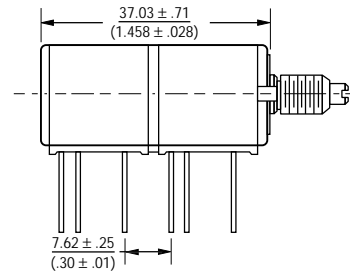

## Switch Module Model 85/86

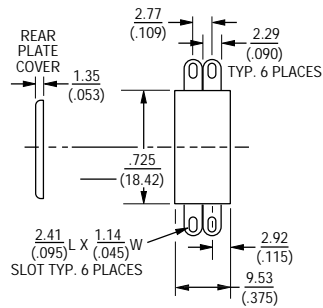

## Assembly Sequence Model 85/86 Secondary Potentiometer Module

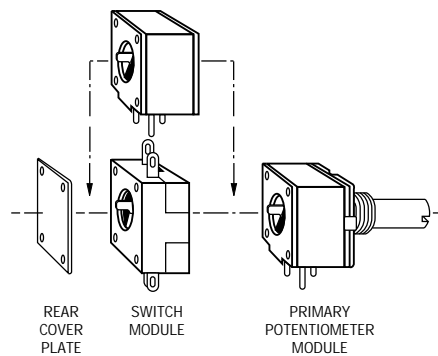

## Dual Section Model 84 Solder Lugs

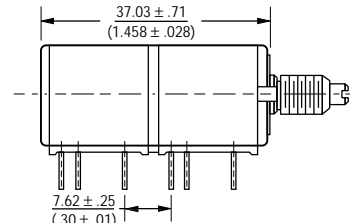

Note: The Models 83/84 dimensions for dual section assembly are for either single or dual concentric shaft styles.

TOLERANCES EXCEPT AS SHOWN: DECIMAL .XXX ± .127 (.005)  
.XX ± .38 (.015)  
ANGLE ± 5%

## Locating Lug Options - All Model 80 Series

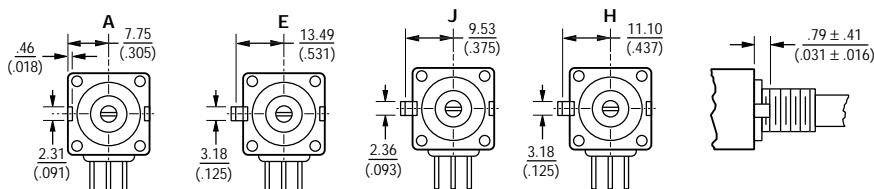

$$E = \frac{2.36 \pm .76}{(.093 \pm .03)} \quad H \& J = \frac{1.98 \pm .41}{(.078 \pm .016)}$$

DIMENSIONS ARE: METRIC / INCHES

# How To Order 80 Series Panel Controls

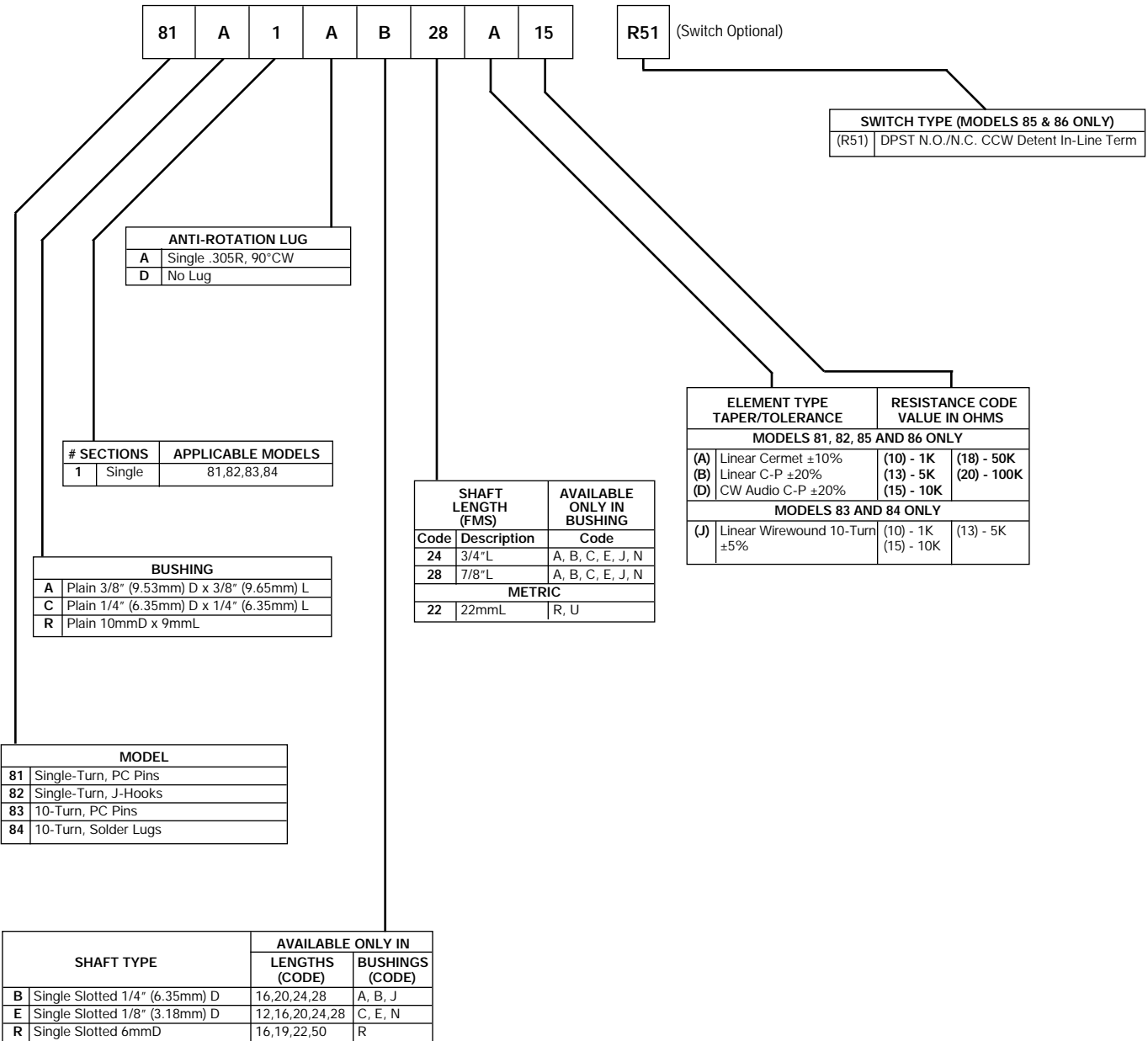

Recommended part numbers, for other options contact the factory. Boldface listings are in stock and readily available through distribution.

Specifications are subject to change without notice.

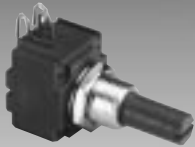

**BOURNS®**

## Features

- Features one-piece molded plastic
- Available in a variety of pin-out shaft and rotor assemblies configurations
- Virtually infinite electrical circuit
- Model 96 sealed for board wash
- Metal shaft available as special feature

## 91, 93, 95, 96 - 5/8" Square Single-Turn

Initial Electrical Characteristics <sup>1</sup>	Conductive Plastic Element	Cermet Element
Standard Resistance Range		
Linear Tapers (A, B, E, & H).....	(B & E) 1K ohms to 1 megohm.....	(A & H) 50 ohms to 1 megohm
Audio Tapers (C, D, F, G, S, & T).....	(D, G, S, & T) 1K ohms to 1 megohm.....	(C & F) 1K ohms to 1 megohm
Resistance Tolerance.....	(B, D, & G tapers) ±20%.....	(A, C, & F tapers) ±10%
	(E, S, & T tapers) ±10%.....	(H taper) ±5%
Independent Linearity.....	(B & E tapers) ±5%.....	(A & H tapers) ±5%
Absolute Minimum Resistance.....	2 ohms maximum.....	2 ohms maximum
Continuity.....	Maintained for full mechanical angle.....	Maintained for full mechanical angle
Effective Electrical Angle.....	240° ±5°.....	240° ±6°
Contact Resistance Variation.....	±1%.....	±1% or 3 ohms (whichever is greater)
Dielectric Withstanding Voltage.....	MIL-STD-202, Method 301.....	MIL-STD-202, Method 301
Sea Level.....	1,500 VAC minimum.....	1,500 VAC minimum
70,000 Feet.....	500 VAC minimum.....	500 VAC minimum
Insulation Resistance (500 VDC).....	1,000 megohms minimum.....	1,000 megohms minimum
Power Rating (Voltage Limited By Power Dissipation or 350 VAC, Whichever Is Less)		
+70°C Single Section Assembly.....	(B & E tapers) 0.5 watt.....	(A & H tapers) 2 watts
	(D, G, S, & T tapers) 0.25 watt.....	(C & F tapers) 1 watt
+70°C Multiple Section Assembly.....	(B & E tapers) 0.5 watt/section.....	(A & H tapers) 1 watt/section
	(D, G, S, & T tapers) 0.25 watt/section.....	(C & F tapers) 0.5 watt/section
+125°C.....	0 watt.....	0 watt
Roll-on/Roll-off.....	(B & E tapers) 0.25% maximum.....	(A & H tapers) 0.5% maximum
	(D & S tapers) 0.1% maximum CCW end.....	(C taper) 0.1% maximum CCW end
	(G & T tapers) 0.1% maximum CW end.....	(F taper) 0.1% maximum CW end
	(D & S tapers) 0.5% maximum CW end.....	(C taper) 1.0% maximum CW end
	(G & T tapers) 0.5% maximum CCW end.....	(F taper) 1.0% maximum CW end
Theoretical Resolution.....	Essentially infinite.....	Essentially infinite

Environmental Characteristics <sup>1</sup>	Conductive Plastic Element	Cermet Element
Operating Temperature.....	+1°C to +125°C.....	+1°C to +125°C
Storage Temperature Range.....	-55°C to +125°C.....	-55°C to +125°C
Temperature Coefficient		
Over Storage Temperature Range.....	±1,000PPM/°C.....	±150PPM/°C
Vibration (Single Section).....	15G.....	15G
Total Resistance Shift.....	±2% maximum.....	±2% maximum
Voltage Ratio Shift.....	±5% maximum.....	±5% maximum
Shock (Single Section).....	30G.....	30G
Total Resistance Shift.....	±2% maximum.....	±2% maximum
Voltage Ratio Shift.....	±5% maximum.....	±5% maximum
Load Life.....	1,000 hours.....	1,000 hours
Total Resistance Shift.....	±10% maximum.....	±5% maximum
Rotational Life (No Load).....	100,000 cycles.....	100,000 cycles
Total Resistance Shift.....	(B & E tapers) 10 ohms or ±15% maximum.....	10 ohms or ±10% maximum
	(whichever is greater)	(whichever is greater)
	(D, G, S, & T tapers) ±20% maximum	
Contact Resistance Variation @ 50,000 cycles.....	(B & E tapers) ±2%.....	
	(D, G, S, & T tapers) ±3%	
Moisture Resistance.....	MIL-STD-202, Method 103, Condition B.....	MIL-STD-202, Method 103, Condition B
Total Resistance Shift.....	(B & E tapers) ±10% maximum.....	(All tapers) ±5% maximum
	(D, G, S, & T tapers) ±20% maximum	
Insulation Resistance (500 VDC).....	100 megohms minimum.....	100 megohms minimum

Mechanical Characteristics <sup>1</sup>	Conductive Plastic Element	Cermet Element
Running Torque		
Single or Dual Section (A, D & r Bushings).....	0.3 to 1.5 oz.-in. (0.21 to 1.06 Ncm).....	0.3 to 1.5 oz.-in. (0.21 to 1.06 Ncm)
Single or Dual Section (C & U Bushings).....	0.2 to 1.5 oz.-in. (0.14 to 1.06 Ncm).....	0.2 to 1.5 oz.-in. (0.14 to 1.06 Ncm)
Starting Torque.....	0.3 maximum above average running torque.....	0.3 maximum above average running torque
Torque Variation.....	0.5 oz.-in. (0.35 Ncm) max. in 45° shaft travel.....	0.5 oz.-in. (0.35 Ncm) max. in 45° shaft travel
Stop Strength (1/4" D shaft).....	4 in.-lb. (45.19 Ncm).....	4 in.-lb. (45.19 Ncm)
(1/8" D shaft).....	3 in.-lb. (33.89 Ncm).....	3 in.-lb. (33.89 Ncm)
Mechanical Angle.....	300° ±5°.....	300° ±5°
Weight (Single Section).....	7 grams maximum.....	7 grams maximum
Each Additional Section.....	4 grams maximum.....	4 grams maximum
Terminals.....	Printed circuit terminals, J-Hooks or solder lugs.....	Printed circuit terminals, J-Hooks or solder lugs
Marking.....	Manufacturer's trademark, date code, resistance, manufacturer's part number.....	Manufacturer's trademark, date code, resistance, manufacturer's part number

FOR DIMENSIONAL DRAWINGS SEE PAGE 226.

FOR ORDERING INFORMATION SEE PAGE 227.

NOTE: ALL MODEL 90 PERFORMANCE SPECIFICATIONS DO NOT APPLY TO UNITS SUBJECTED TO PRINTED CIRCUIT BOARD CLEANING PROCEDURES, EXCEPT FOR THE SEALED VERSION (MODEL 96).

<sup>1</sup>AT ROOM AMBIENT: +25°C NOMINAL AND 50% RELATIVE HUMIDITY NOMINAL, EXCEPT AS NOTED.

Specifications are subject to change without notice.

# 91, 93, 95, 96 Dimensions and Tolerances



## Model 91 PC Pin Terminals, In-Line

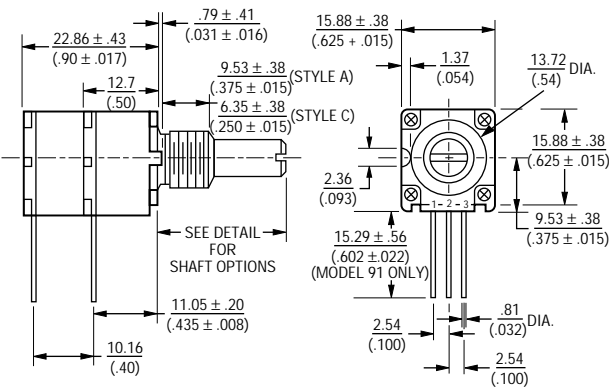

## Model 95 Solder Lug Terminals, "Triangular" Pattern

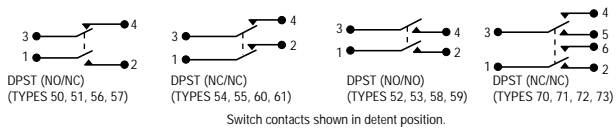
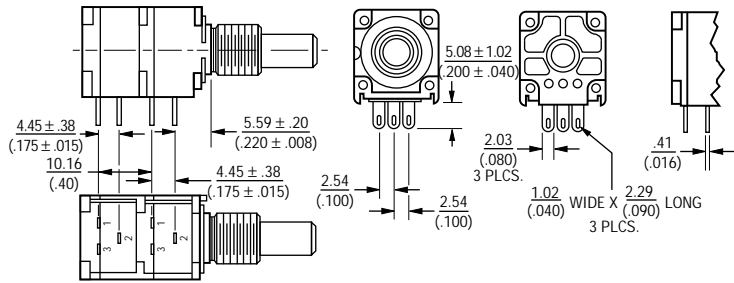

## Model 93 PC Pin Terminals, "L" Pattern

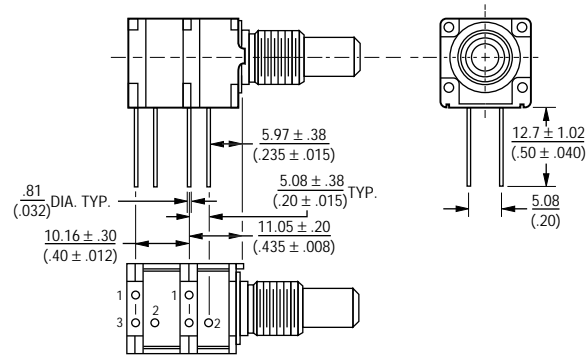

## Bushing Styles

- 3/8 THREADLESS (9.53mm) (STYLE "D")
- 3/8-32 UNEF (9.53mm) (STYLE "A")
- 1/4-32 UNEF (6.35mm) (STYLE "C")
- M10 X 0.75-6g (STYLE "R")
- M7 X 0.75-6g (STYLE "U")

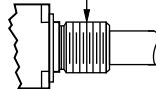

## Shaft Styles

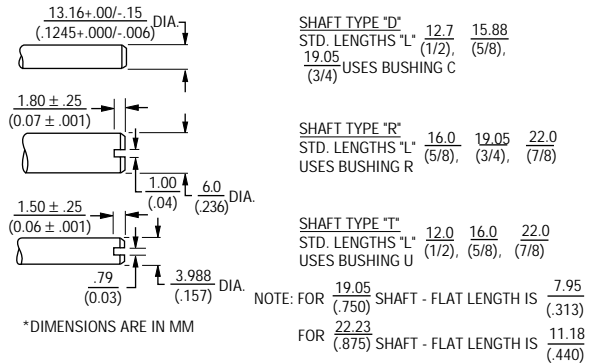
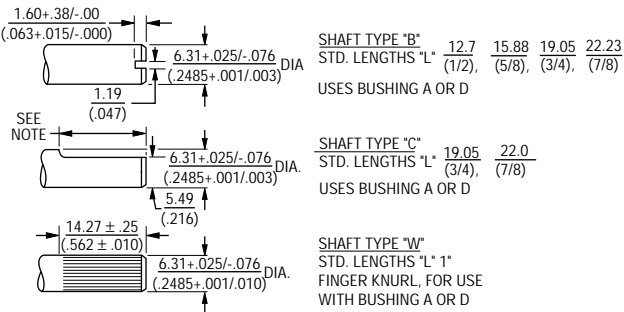

TOLERANCES EXCEPT AS SHOWN: DECIMAL .XXX ±  $\frac{.128}{.015}$ , FRACTION ± 1/64, .XX ±  $\frac{.005}{.38}$  ANGLE ± 5°

DIMENSIONS ARE: METRIC / (INCHES)



# 90 Series Panel Controls Dimensions and Tolerances **BOURNS®**

## How To Order

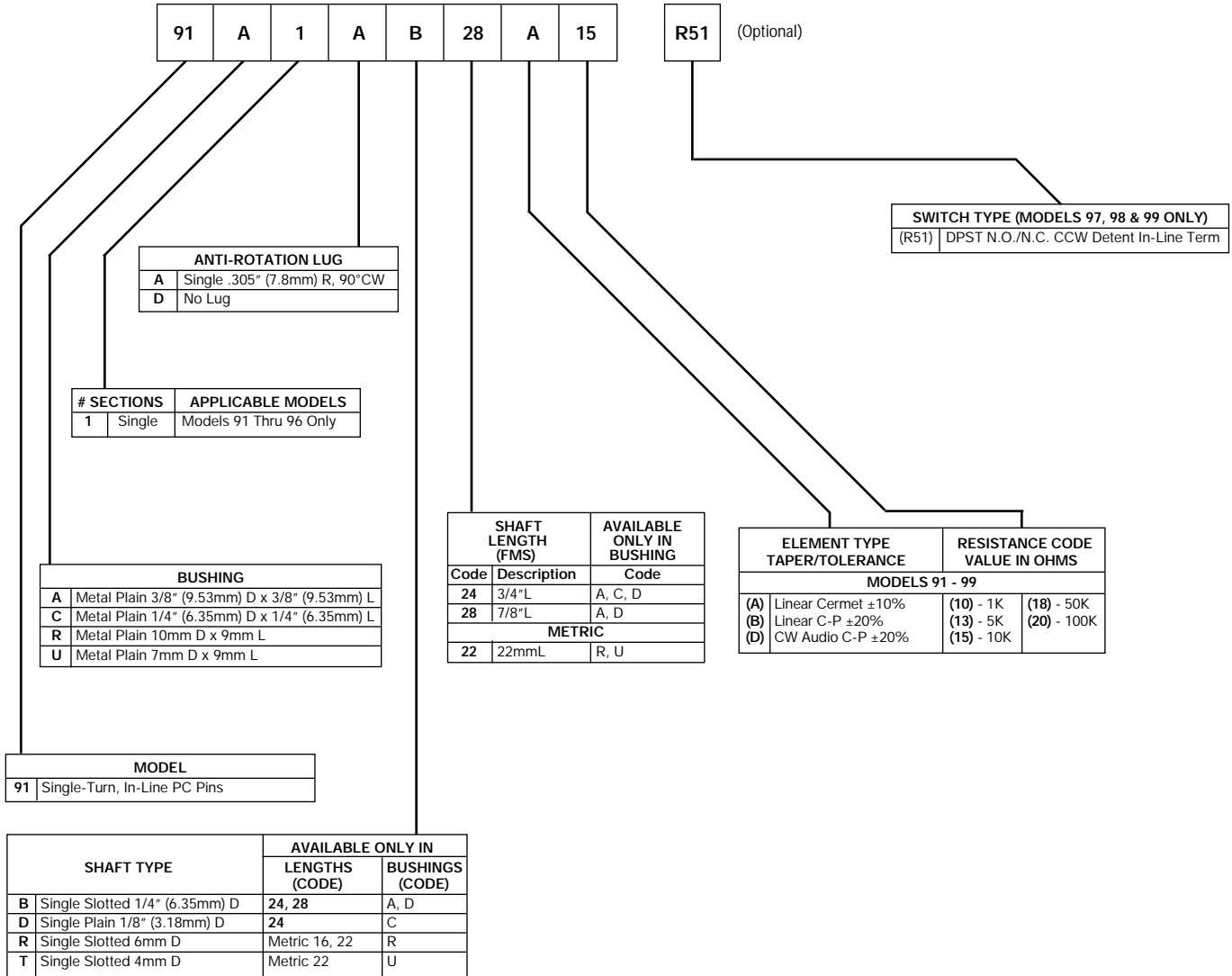

Recommended part numbers.  
For other options contact the factory.  
Boldface listings are in stock and readily available through distribution.



## Features

- Single-turn (3851 and 3852)
- Linear and audio tapers
- 3-3/4-turn (3856)
- Wide resistance range
- Minimal depth package
- Good resolution

## 3851/3852/3856 - 3/4" Diameter Panel Control

### Initial Electrical Characteristics<sup>1</sup>

	3851 Conductive Plastic Element	3852/3856 Cermet Element
Standard Resistance Range		
Linear Tapers (A, B, E, and H)	1K to 1 megohm	100 ohms to 1 megohm
Audio Tapers (C, D, F, and G)	1K to 1 megohm	1K ohms to 1 megohm
Resistance Tolerance	±20%	±10%
Zero Base Linearity	(B, D, & G tapers) ±20% (E taper) ±10%	(A, C, & F tapers) ±10% (H taper) ±5%
Independent Linearity	±10%	(A & H tapers) ±5%
Absolute Minimum Resistance	2 ohms maximum	2 ohms maximum
Continuity	Maintained for full mechanical angle	Maintained for full mechanical angle
Effective Electrical Angle	250° ±5°	250° ±5°
Contact Resistance Variation	±1%	±3% of total resistance or 3 ohms (whichever is greater)
Dielectric Withstanding Voltage	MIL-STD-202, Method 301	MIL-STD-202, Method 301
Sea Level	900 VAC minimum	900 VAC minimum
70,000 Feet	350 VAC minimum	350 VAC minimum
Insulation Resistance (500 VDC)	1,000 megohms minimum	1,000 megohms minimum
Power Rating (Voltage Limited By Power Dissipation or 316 VAC, Whichever Is Less)		
+70°C	(B & E tapers) 1 watt (D & G tapers) 0.5 watt	(A & H tapers) 2 watts (C & F tapers) 1 watt
+125°C	0 watt	
+150°C		0 watt
Theoretical Resolution	Essentially infinite	Essentially infinite

### Environmental Characteristics<sup>1</sup>

Operating Temperature		-1°C to +125°C
Storage Temperature Range		-65°C to +125°C
Temperature Coefficient		
Over Storage Temperature Range	±1,000PPM/°C	±150PPM/°C
Vibration	20G	20G
Total Resistance Shift	±2% maximum	±2% maximum
Voltage Ratio Shift	±5% maximum	±6% maximum
Shock	100G	100G
Total Resistance Shift	±2% maximum	±2% maximum
Voltage Ratio Shift	±5% maximum	±6% maximum
Load Life	1,000 hours	1,000 hours
Total Resistance Shift	±10% maximum	±3% maximum
Rotational Life (No Load)	100,000 cycles	50,000 cycles
Total Resistance Shift	±15% maximum	±5% or 5 ohms (whichever is greater)
Moisture Resistance	MIL-STD-202, Method 103, Condition B	MIL-STD-202, Method 103, Condition B
Total Resistance Shift	±10% maximum	±2% maximum
Insulation Resistance (500 VDC)	100 megohms minimum	100 megohms minimum

### Mechanical Characteristics<sup>1</sup>

Shaft Torque	(A & B bushings) .05 to 6.0 oz.-in. (0.35 to 4.23 Ncm) (C & E bushings) 0.3 to 6.0 oz.-in. (0.21 to 4.23 Ncm)	3852 (A & B bushings) 0.5 to 6.0 oz.-in. (0.35 to 4.23 Ncm) (C & E bushings) 0.3 to 6.0 oz.-in. (0.21 to 4.23 Ncm) 3856 — 0.15 to 3.0 oz.-in. (0.11 to 2.12 Ncm)
Stop Strength	5 in.-lb. (56.5 Ncm)	5 in.-lb. (56.5 Ncm)
Mechanical Angle	280° ±5°	3852 — 280° ±5° 3856 — 1350° ±50°
Weight	30 grams maximum	30 grams maximum
Terminals	Printed circuit terminals or solder lugs	Printed circuit terminals or solder lugs
Marking	Manufacturer's trademark, wiring diagram, date code, resistance, manufacturer's part number	Manufacturer's trademark, wiring diagram, date code, resistance, manufacturer's part number

FOR ORDERING INFORMATION SEE PAGE 229.

<sup>1</sup>AT ROOM AMBIENT: +25°C NOMINAL AND 50% RELATIVE HUMIDITY NOMINAL, EXCEPT AS NOTED.

# 3851/3852/3856 Dimensions and Tolerances



## 3851A/3852A

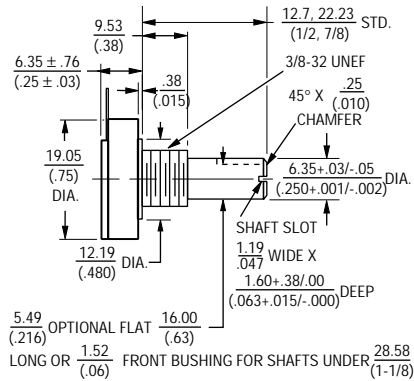

## 3851B/3852B

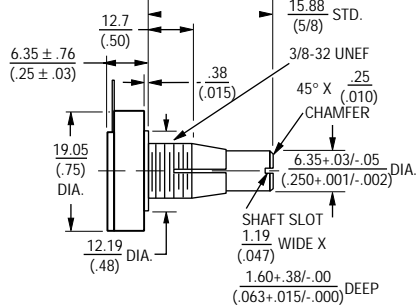

## Terminal Configuration

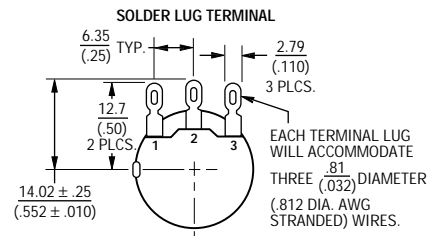

## 3851C/3852C

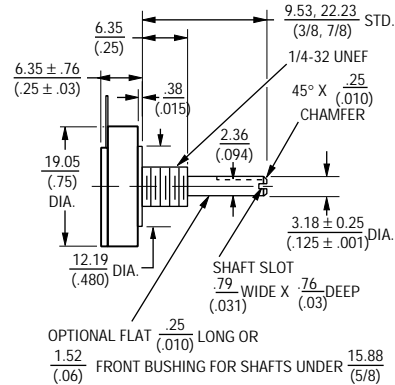

## 3851E/3852E

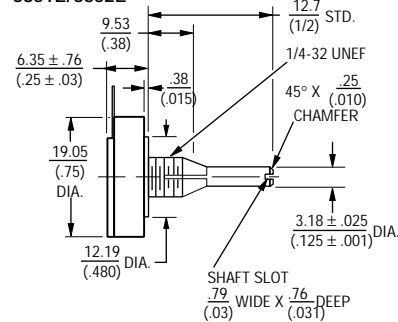

## 3851/3852/3856

### A, B & H BUSHINGS

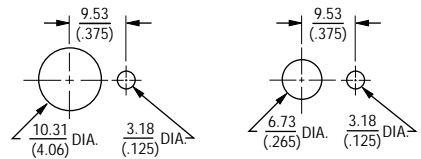

## 3856A

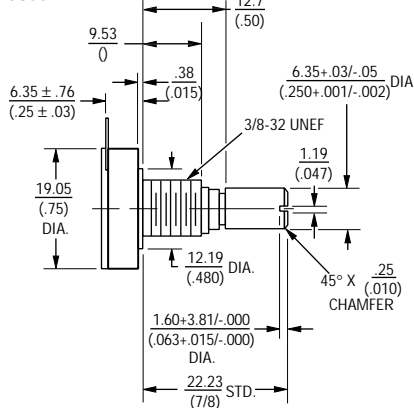

## 3856H

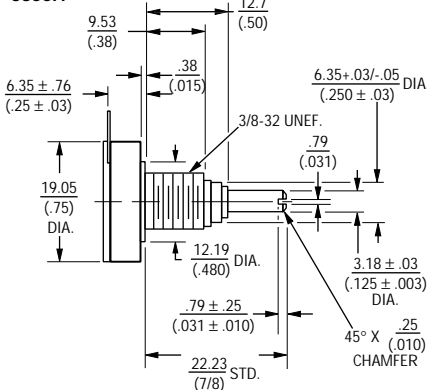

## Shaft End Detail

### 3850 Family

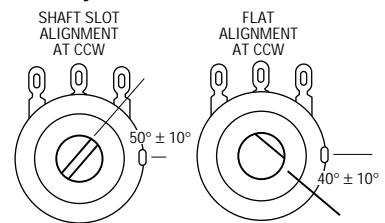

TOLERANCES EXCEPT AS NOTED:  
 DECIMALS:  $.XX \pm \frac{.127}{.005}$ ,  $.XX \pm \frac{.38}{.015}$   
 FRACTIONS:  $\pm 1/64$   
 ANGLE:  $\pm 3\%$

DIMENSIONS ARE:  $\frac{\text{METRIC}}{\text{(INCHES)}}$



## Features

- Small diameter
- Wide resistance range
- Good resolution
- Linear tapers

**BOURNS®**

# 3862 - 1/2" Diameter Single-Turn Panel Control

### Initial Electrical Characteristics<sup>1</sup>

Standard resistance Range (A & H Tapers).....	100 ohm to 5 megohms
Resistance Tolerance .....	(A Taper) ±10%
	(H Taper) ±5%
Independent Linearity.....	±5%
Absolute Minimum Resistance .....	2 ohms maximum
Continuity .....	Maintained for full mechanical angle
Effective Electrical Angle.....	260° ±10°
Contact Resistance Variation.....	±3% of total resistance
Theoretical Resolution.....	Essentially infinite
Dielectric Withstanding Voltage .....	MIL-STD-202, Method 301
Sea Level.....	750 VAC minimum
70,000 Feet.....	350 VAC minimum
Insulation Resistance (500 VDC).....	1,000 megohms minimum
Power Rating (Voltage Limited by Power Dissipation or 350 VAC, Whichever is Less)	
+70°C .....	.1 watt
+125°C .....	.0 watt

### Environmental Characteristics<sup>1</sup>

Operating Temperature .....	-1°C to +125°C
Storage Temperature Range .....	-65°C to +125°C
Temperature Coefficient Over Temperature Range .....	±150 ppm/°C
Vibration .....	.20G
Total Resistance Shift .....	±2% maximum
Voltage Ratio Shift .....	±6% maximum
Shock .....	.50G
Total Resistance Shift .....	±2% maximum
Voltage Ratio Shift .....	±6% maximum
Load Life .....	1,000 hours
Total Resistance Shift .....	±3% maximum
Rotational Life (C & N Bushing) (No Load).....	50,000 cycles
Total Resistance Shift .....	±5% maximum
Moisture Resistance .....	MIL-STD-202, Method 106, Condition B
Total Resistance Shift .....	±2% maximum
Insulation Resistance (500 VDC) .....	100 megohms minimum
Salt Spray.....	MIL-STD-202, Method 101, Condition A

### Mechanical Characteristics<sup>1</sup>

Shaft Torque .....	.5 oz.-in. (3.53 Ncm) maximum
Shaft Locking Torque with Locking Bushings .....	.20 oz.-in. (14.12 Ncm)
Mechanical Angle .....	295° ±3°
Weight .....	.25 grams maximum
Terminals.....	Printed circuit pins or J-Hooks
Markings.....	Mfr's. trademark, wiring diagram, date code, resistance, manufacturer's part number
Stop Strength.....	.3 in.-lb. maximum

#### PCB LAYOUT

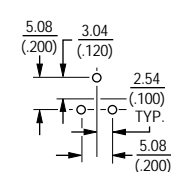

#### PANEL LAYOUT

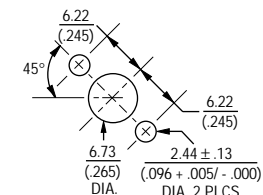

<sup>1</sup>AT ROOM AMBIENT: +25°C NOMINAL AND 50% RELATIVE HUMIDITY NOMINAL, EXCEPT AS NOTED.

#### 3862E/T

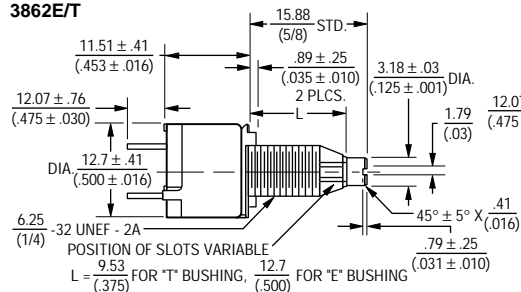

#### 3862C/N

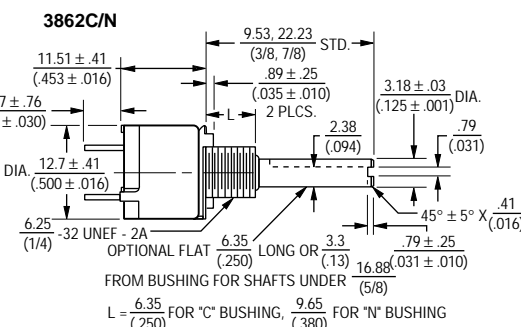

#### Shaft End Detail 3862

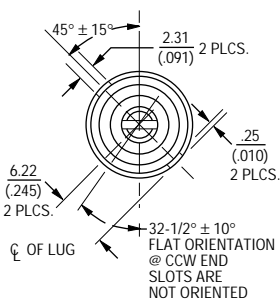

DIMENSIONS ARE: METRIC (INCHES)

# 3800 Series Dimensions and Tolerances



## Dimensional Drawings And Tolerances

PC PIN TERMINAL

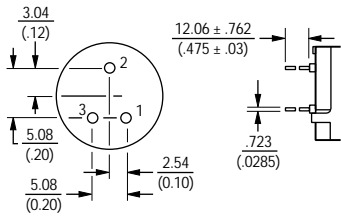

J-HOOK TERMINAL

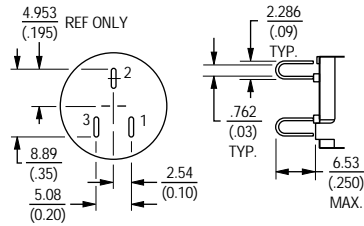

DIMENSIONS ARE: METRIC (INCHES)

## How To Order

3852 A 28 2 103 A

	SHAFT TYPE (FMS) & DIAMETER	AVAILABLE ONLY IN	
		MODELS	BUSHINGS
12	3/8" (9.53mm) L X 1/8" (3.18mm) D	3851, 3852, 3862	C
16	1/2" (12.7mm) L X 1/8" (3.18mm) D	3851, 3852, 3862	C, E C
20	5/8" (15.88mm) L X 1/4" (6.35mm) D	3851, 3852	A, B
28	7/8" (22.20mm) L X 1/4" (6.35mm) D	3851, 3852, 3856	A, B A

Consult factory for lengths not shown.

BUSHING	APPLICABLE MODELS
A Plain 3/8" (9.53mm) D x 3/8" (9.53mm) L	3851, 3852, 3856
C Plain 1/4" (6.35mm) D x 1/4" (6.35mm) L	3851, 3852, 3862

RESISTANCE CODE/VALUE (IN OHMS)	
Models 3851, 3852, 3856, 3862	
(102)	1K
(502)	5K
(103)	10K
(503)	50K
(104)	100K

MODEL	
3852	3/4" (19.05mm) D Single-Turn Cermet
3862	1/2" (12.7mm) D Single-Turn Cermet

TERMINAL STYLE AND SHAFT TYPE	
2	Solder Lugs*, Slotted End
6	PC Pins, Slotted End

\*Model 3862 comes with J-hook solder lugs.

ELEMENT TAPER/TOLERANCE		APPLICABLE MODELS
A	Linear ±10%	3852, 3856, 3862

\*The maximum resistance range for audio tapers is 1000 ohms to 2.5 megohms.



## Features

- Minimal installation space for maximum design flexibility
- Linear or audio taper versions
- Wide assortment of options

**BOURNS**<sup>®</sup>

## Open-Frame Slide Potentiometer

### Electrical Characteristics

	20MM
Standard Resistance Range.....Linear..... (ohms) Audio.....	2K 5K 10K 20K 50K 100K 200K 500K 5K 10K 20K 50K 100K 200K 500K
Resistance Tolerance .....	±20%, All Resistance/Tapers
Resistance Taper .....Linear .....	B Tapers (see taper curves)
Independent Linearity.....	±5% for B Tapers
Absolute Minimum Resistance.....	1% or 100 ohms, whichever is less, for B taper
Continuity .....	Maintained for full stroke
Effective Electrical Travel.....	90% of Mechanical Travel
Peak Noise (CRV) Linear/Audio.....	2% / 5%
Theoretical Resolution.....	Essentially Infinite
Dielectric Strength (Sea Level) .....	500 VAC, 1 minute, between Lever and Terminals
Insulation Resistance (500 VDC) .....	1,000 megohms minimum between Lever and Terminals
Power Rating at 70°C.....Linear .....	0.1 Watt
(0 Watt at 90°C) Audio.....	0.05 Watt
Maximum Working Voltage.....	Power Dissipation or 350 VAC, whichever is less
Tracking Error (Dual Only).....	4 dB maximum; 0 to -40 dB
<b>Environmental Characteristics</b>	
Storage Temperature.....	-20°C to +90°C
Temperature Coefficient of Resistance .....	±1,000ppm/°C
Vibration (10 to 55 Hz, 1.5mm).....	Voltage Ratio Change: ±5% maximum. Total Resistance Shift: ±2% maximum
Load Life .....	(Pre-conditioning: 55°C, 20% RH, 24 ± 4 Hours)
(Rated Power at 25°C for 1,000 Hours).....	Total Resistance Shift: ±10%
Sliding Life .....	Total Resistance Shift: ±5% = Linear; 2K, 5K, 10k, 20K, 50K,
(No Load - 15,000 Cycles)	±10% = Linear; 100K, 200K, 500K, & Audio; 2K to 500k
Moisture Resistance (96 Hours @ 40°C .....	Total Resistance Shift: Linear ±12% maximum, Audio ±20% maximum
90-95% RH, Rated Power)	Insulation Resistance: 100 megohms minimum
Soldering Heat (3 Seconds @ 350°C).....	Total Resistance Shift: ±5% maximum
<b>Mechanical Characteristics</b>	
Operating Force .....	15 to 150 Gr
Stop Strength .....	1.5 Kg minimum
Stroke .....	20mm
Terminals .....	PC Pins (Vertical or Horizontal)
Markings.....	Trademark, date code, taper, and resistance (ex. B10K) and Japan

# Slide Potentiometer - Dimensions and Tolerances

**BOURNS®**

## TAPER CURVES

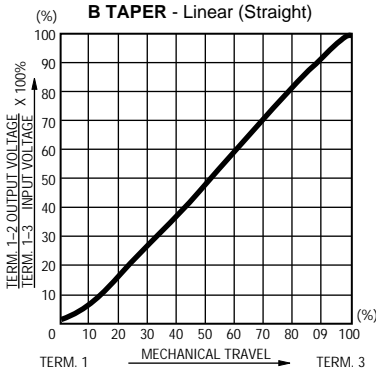

### Single Element Vertical Mount

MODEL	DIMENSIONS ± 0.20 (± 0.5)			
	L (STROKE)	A	B	C
SSVA30XXXXXX	1.81 (30)	1.969 (50)	1.535 (39)	1.953 (49.6)
SSVA20XXXXXX	.787 (20)	1.575 (40)	1.142 (29)	1.559 (39.6)
SSVA15XXXXXX	.591 (15)	1.378 (35)	.945 (24)	1.362 (34.6)
SSVA10XXXXXX	.394 (10)	1.181 (30)	.748 (19)	1.165 (29.6)

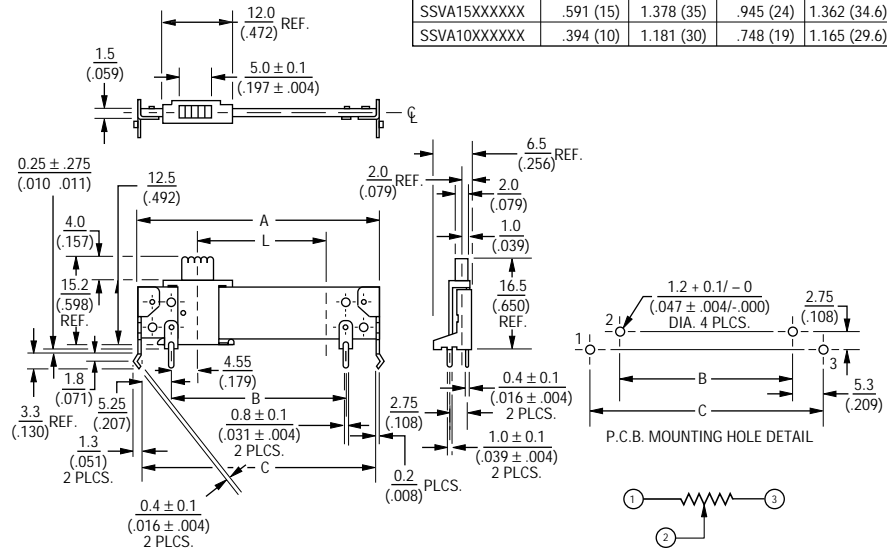

### Single Element Horizontal Mount

MODEL	DIMENSIONS ± 0.20 (± 0.5)		
	L (STROKE)	A	B
SSHA30XXXXXX	1.81 (30)	1.535 (39)	1.929 (49)
SSHA20XXXXXX	.787 (20)	1.142 (29)	1.535 (39)
SSHA15XXXXXX	.591 (15)	.945 (24)	1.339 (34)
SSHA10XXXXXX	.394 (10)	.748 (19)	1.142 (29)

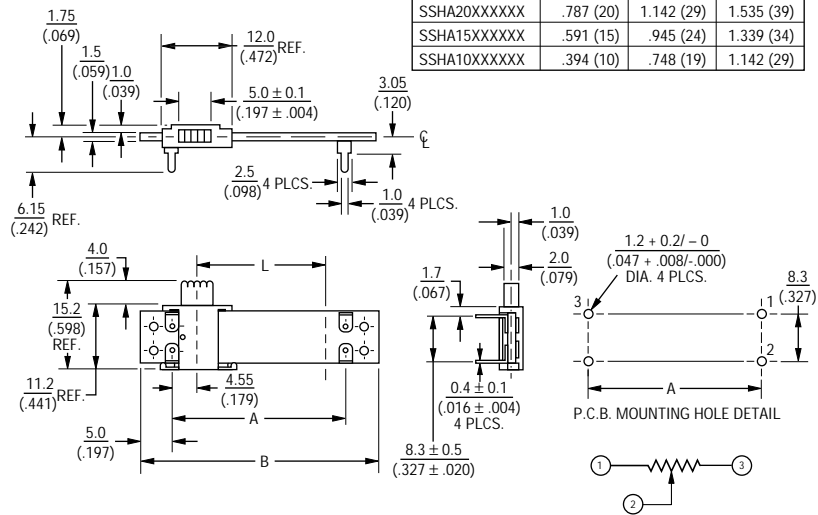

Non-stock adjustable

DIMENSIONS ARE: METRIC (INCHES)

# Slide Potentiometers - How to Order

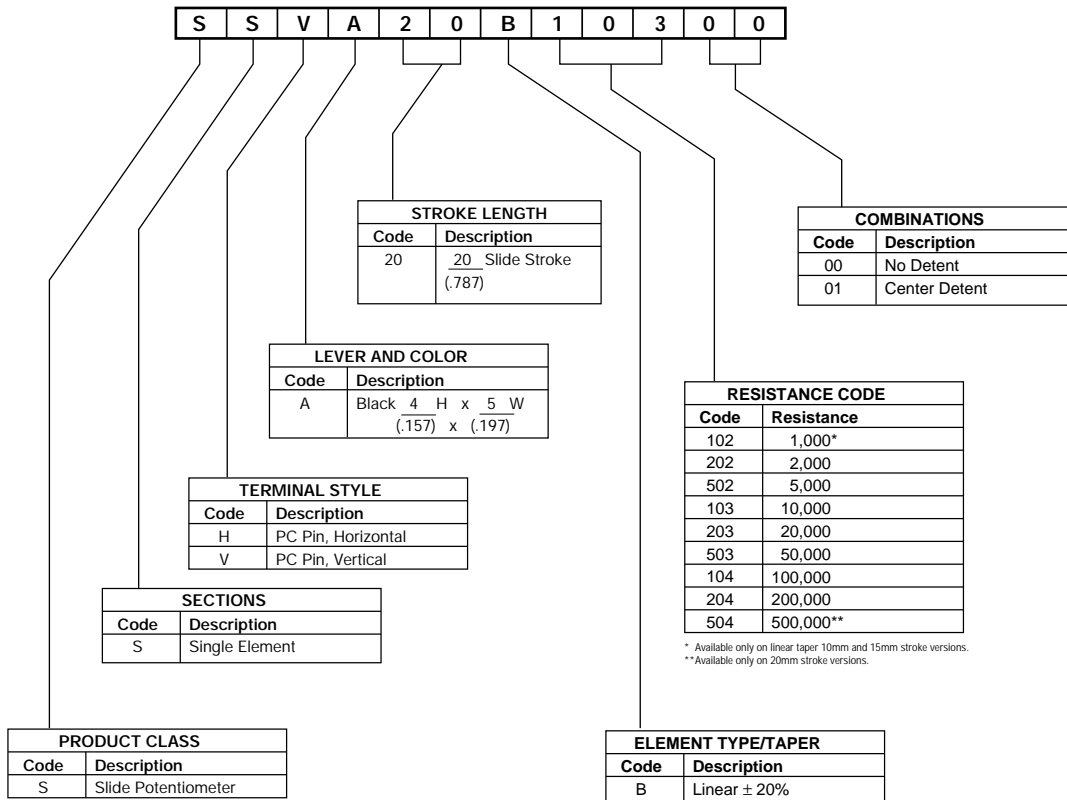



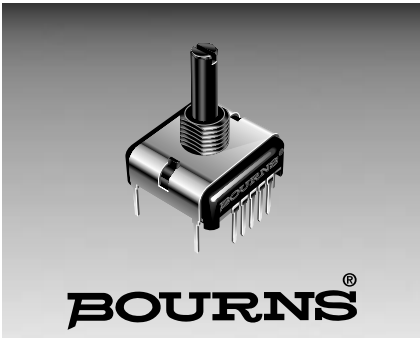

## Features

- Space saving design
- Wide range of resistance values
- PC pin or solder lug terminals
- Metric shaft and bushing option
- Mounting brackets available
- Linear or audio taper versions

## Slimline Potentiometer

### Electrical Characteristics - Potentiometer

Standard Resistance Range	
Linear Tapers .....	500 ohms to 1.5 megohms
Audio Tapers .....	1K ohms to 500K ohms
Resistance Tolerance (All Tapers) .....	±20%
Independent Linearity .....	±5% (linear taper)
Absolute Minimum Resistance .....	5 ohms maximum
Effective Electrical Angle .....	270° ± 5°
Dielectric Withstanding Voltage .....	
Sea Level .....	MIL-STD-202, Method 301
70,000 Feet .....	1,000 VAC minimum
Insulation Resistance (500 VDC) .....	500 VAC minimum
Power Rating @ 70°C (Voltage Limited by Power Dissipation or 350 VAC, Whichever is Less)	1,000 megohms
Linear .....	.75 watt
Audio .....	.25 watt

### Environmental Characteristics

Operating Temperature .....	+1°C to +125°C
Storage Temperature .....	-40°C to +125°C
Load Life (1,000 Hours @ Rated Power, 20% RH, 70°C) .....	±10% maximum resistance shift
Rotational Life .....	50,000 cycles
Total Resistance Shift	
Linear .....	±10 ohms or 12%, whichever is greater
Audio .....	±20% maximum

### Mechanical Characteristics

Stop Strength (1/4" and 6mm Shaft Diameters) .....	7 in.-lb. (79.09 Ncm)
Mechanical Angle .....	300° ± 5°
Terminals .....	PC pin or solder lug
Running Torque .....	0.25 to 1.5 in.-oz. (0.18 to 1.06 Ncm) (undetented)
Mounting Torque .....	7 in.-lbs. (79.09 Ncm) maximum
Detents .....	Center, 10, 20, 30, none
Shaft Variations .....	See diagram

### Product Dimensions

#### PC PINS (Rear Facing)

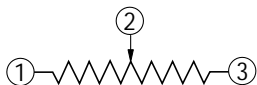
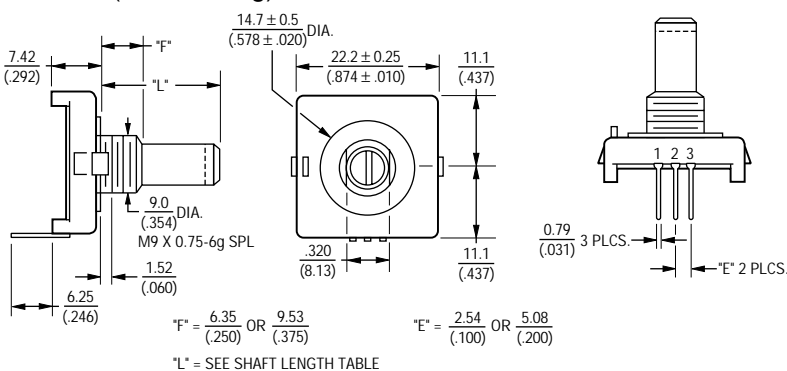

TOLERANCES WHERE NOT SHOWN  
 .XX = ± .010  
 .XXX = ± .005

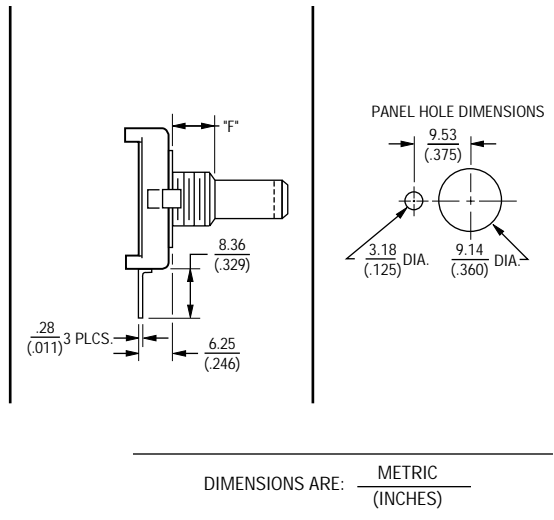

\*For lower contact resistance, consult factory.  
 For additional features or specifications not shown, consult factory.

FOR ORDERING INFORMATION SEE PAGE 237.

Specifications are subject to change without notice.

# Slimline Potentiometers - Dimensions and Tolerances



## SOLDER LUGS

(Dimensions not given are the same as PC pins (rear facing).)

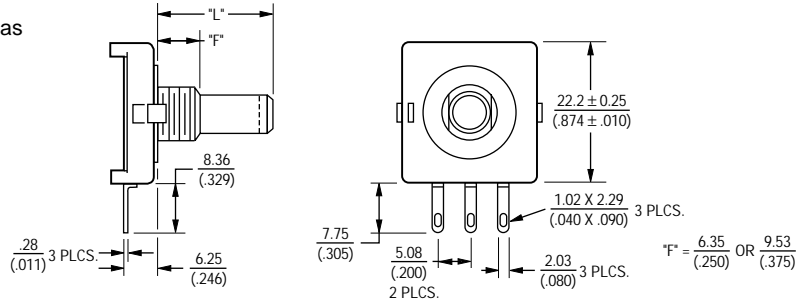

## PC PINS (Rear Facing) With Rear Mounting Bracket

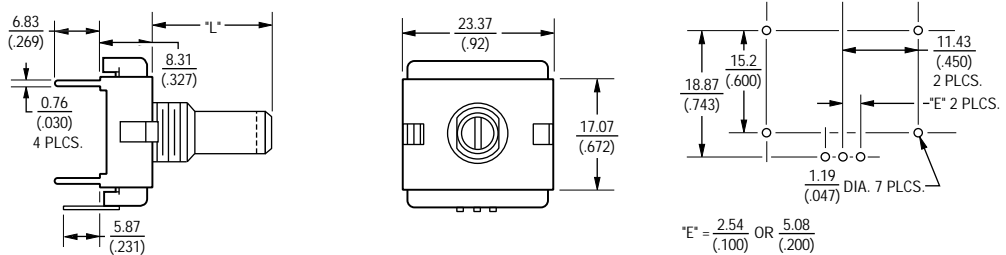

## PC PINS (Side Exit) With Side Mounting Bracket

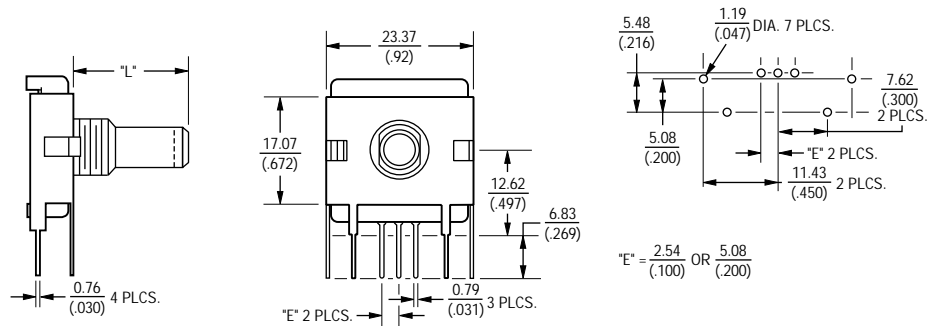

## SHAFT STYLES AND ORIENTATION (Full CCW Rotation)

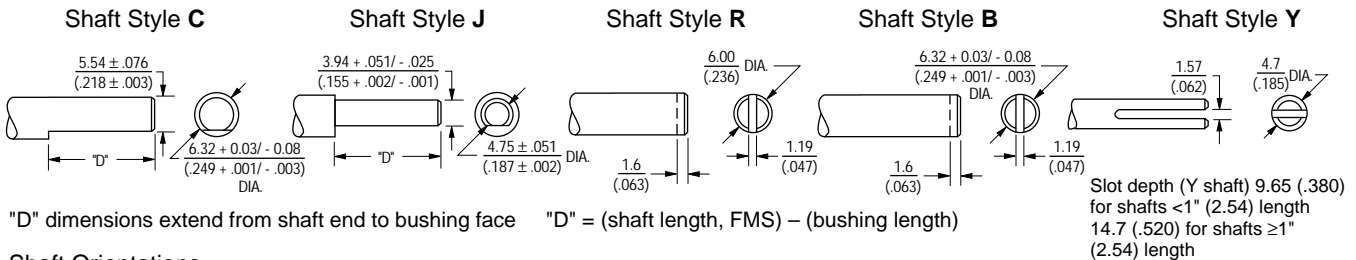

## Shaft Orientations

Shaft Styles C, J

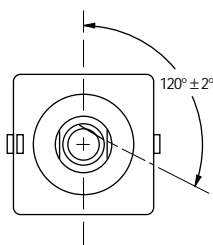

Shaft Styles B, R

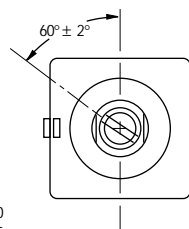

Shaft Style Y

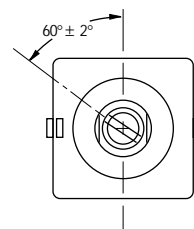

TOLERANCES WHERE NOT SHOWN .XX =  $\pm$  .010  
.XXX =  $\pm$  .005

# Slimline Potentiometers - How To Order



P C W 1 J - B 2 4 - B A B 1 0 3

SHAFT LENGTH (FMS)		
Code	Description	Available Shaft Styles
24	3/4" (19mm) Length	B, C, J, Y
28	7/8" (22.2mm) Length	B, C, J, Y
Metric		
24	24mm Length	R

RESISTANCE VALUES			
Code	TR	Code	TR
502	5KΩ	103	10KΩ
		503	50KΩ
		104	100KΩ

ELEMENT TAPER VERSIONS	
Code	Taper Description
B	Lin. CP± 20%

SHAFT STYLES (See Outline Drawing)	
Code	Description
B	1/4" (6.35mm) Dia. Slotted
C	1/4" (6.35mm) Dia. Flat Head
R	6mm Dia. Slotted (Use Metric Lengths Only)

ANTI-ROTATION LUG	
Code	Description
J	9:00 Position

NO. SECTIONS	
Code	Description
1	Single

DETENT CONFIGURATIONS	
Code	Taper Description
A	No Detents

BUSHING CONFIGURATION		
Code	Description	Available Shaft Styles
W	9mm x .250" (6.35mm) Length Threaded M9 x 0.75 6g 5 Pl	All

HOUSING TERMINAL CONFIGURATION		
Features	Code	
	B	K
Rear Mounting Bracket	X	X
Side Mounting Bracket		
Rear Facing Terminals .100" (2.54mm) Centers	X	X
Side Exiting Terminals .100" (2.54mm) Centers		
Side Exiting Terminals .200" (5.08mm) Centers		
Solder Lugs .200" (5.08mm) Centers		
Rear Facing Terminals .200" (5.08mm) Centers		
Hardware Included		X

Panel mount hardware not included as standard on bracketed versions. The sample part number demonstrates the identification code for Bourns Slimline Potentiometers. The part number shown is a commonly used model, typically available from stock.

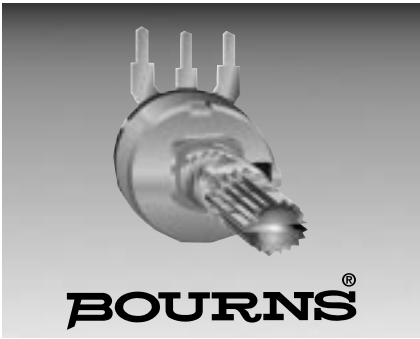

**BOURNS®**

**Features**

- Carbon element
- Switch option
- Wide assortment of resistance tapers

**Applications**

- Audio/TV sets
- Car radio
- Amplifiers/mixers/drum machines/synthesizers
- PCs/monitors
- Appliances

**PDA17 Series - 17mm Rotary Potentiometer**

**Electrical Characteristics**

Taper .....A, B  
 Standard Resistance Range .....1K ohms to 1M ohms  
 Standard Nominal Resistance Value .....See standard resistance table  
 Standard Resistance Tolerance .....±20%  
 Residual Resistance .....Max. 1% overall resistance

**Environmental Characteristics**

Power Rating  
 Taper B .....0.1 watt  
 Taper A .....0.05 watt  
 Maximum Operating Voltage  
 Taper B .....200 V  
 Taper A .....150 V  
 Sliding Noise .....47mV maximum

**Physical Characteristics**

Mechanical Angle .....260° ±10°  
 Rotational Torque .....50 to 350 gcm  
 Stop- End Strength .....5 kgcm minimum  
 Switch Torque .....150 to 450 gcm  
 Switch Action Angle .....60° max.  
 Rotational Life .....15,000 cycles minimum  
 Soldering Condition .....260°C max. within 3 seconds

**PDA17 Series Dimensions**

K-Shaft (18 Toothed Serration Type)

L	20	25
	(.787)	(.984)
B	9	12
	(.354)	(.472)

**Product Dimensions**

**PDA17-SS**

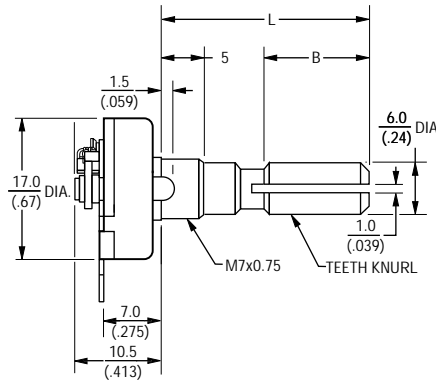

**PDA17-SN**

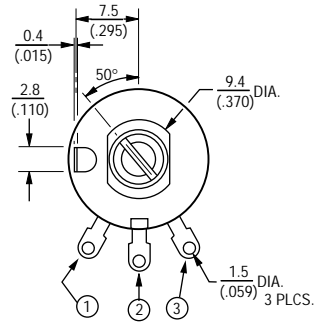
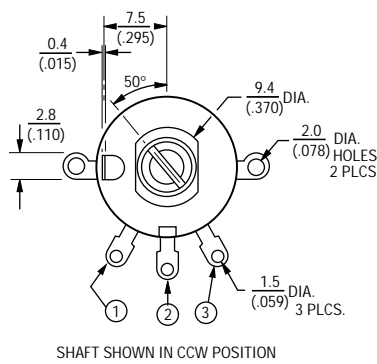
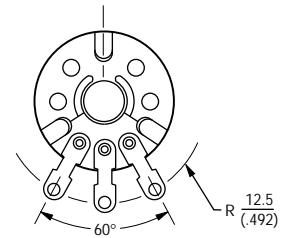
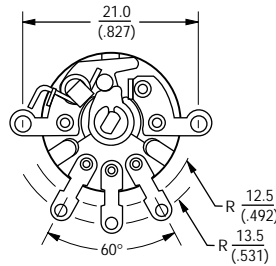
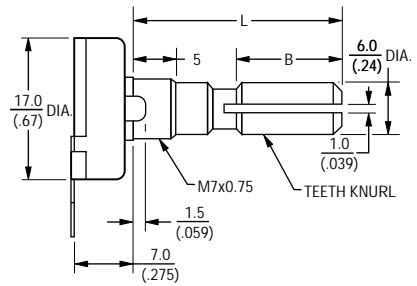

SHAFT SHOWN IN CCW POSITION

DIMENSIONS ARE: METRIC (INCHES)

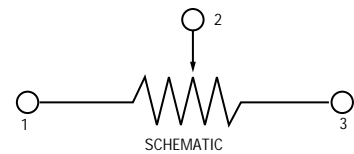

# PDA17 Series - 17mm Rotary Potentiometer

## Product Dimensions

PDA17-AN

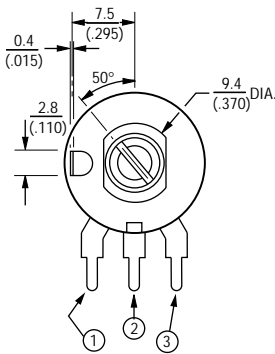
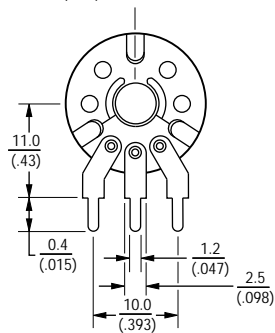
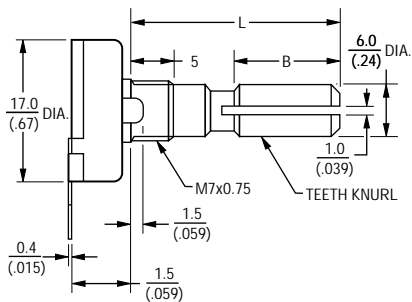

SHAFT SHOWN IN CCW POSITION

PDA17-VN

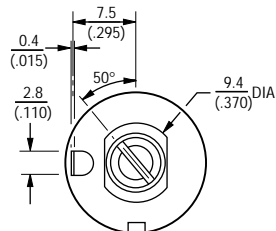
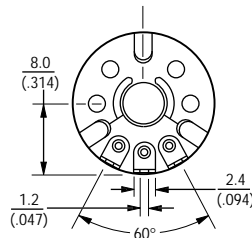
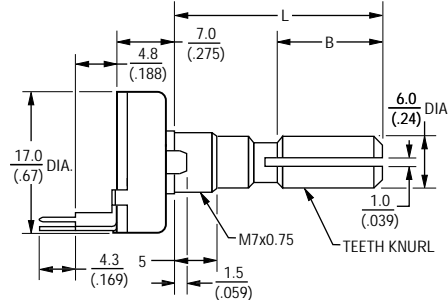

RECOMMENDED PCB LAYOUT

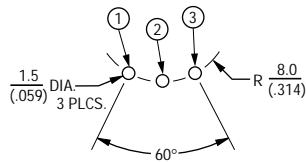

SHAFT SHOWN IN CCW POSITION

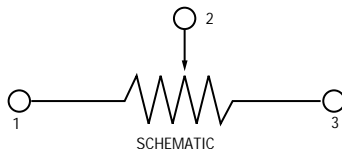

## How To Order

**PDA17 - V N 20 - 102 A K**

- Model \_\_\_\_\_
- Terminal Configuration \_\_\_\_\_
- S = Solder Lugs
  - A = PC Pins vertical/Down Facing
  - V = PC Pins horizontal/Rear Facing
- Switch Option \_\_\_\_\_
- S = Switch
  - N = No Switch
- Standard Shaft Length \_\_\_\_\_
- 20 = 20mm
  - 25 = 25mm
- Resistance Code (See Table) \_\_\_\_\_
- Resistance Taper \_\_\_\_\_
- A = Audio Taper
  - B = Linear Taper
- Shaft Style \_\_\_\_\_
- K = Metal Knurled Shaft  
18 Toothed Serration Type
- Other configurations or styles available.

## Standard Resistance Table

Resistance (Ohms)	Resistance Code
1,000	102
2,000	202
5,000	502
10,000	103
20,000	203
50,000	503
100,000	104
200,000	204
500,000	504
1,000,000	105

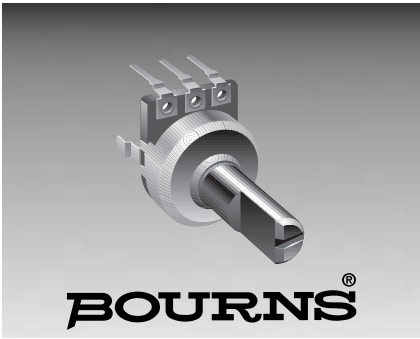

**Features**

- Single gang panel control
- Carbon element
- Center detent option
- Wide range of resistance tapers
- Insulated shaft styles
- Assortment of pin layouts

**Applications**

- Audio/TV sets
- Car radio
- Amplifiers/mixers/drum machines/synthesizers
- PCs/monitors
- Appliances

**PDB12 Series - 12mm Rotary Potentiometer**

**Electrical Characteristics**

Taper .....A, B  
 Standard Resistance Range .....1K ohms to 1M ohms  
 Standard Nominal Resistance Value .....See standard resistance table  
 Standard Resistance Tolerance .....±20%  
 Residual Resistance.....Max. 10 ohms

**Environmental Characteristics**

Power Rating  
 Taper B .....0.08 watt  
 Taper A .....0.04 watt  
 Maximum Operating Voltage  
 Taper B .....150 V  
 Taper A .....100 V  
 Sliding Noise.....47mV maximum

**Physical Characteristics**

Mechanical Angle .....300° ±5°  
 Rotational Torque.....20 to 200 gcm  
 Stop- End Strength .....3 kgcm minimum  
 Rotational Life .....15,000 cycles minimum  
 Soldering Condition .....260°C max. within 3 seconds

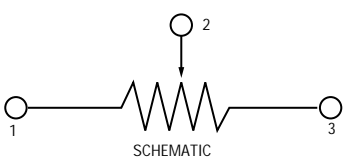

**Product Dimensions**

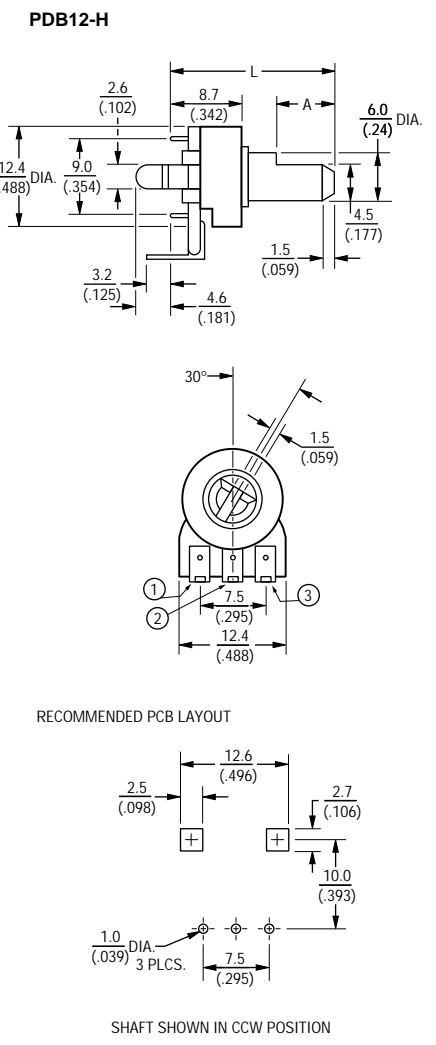

**PDB12-H Dimensions**

L	20	25
	(.787)	(.984)
A	7	12
	(.275)	(.472)

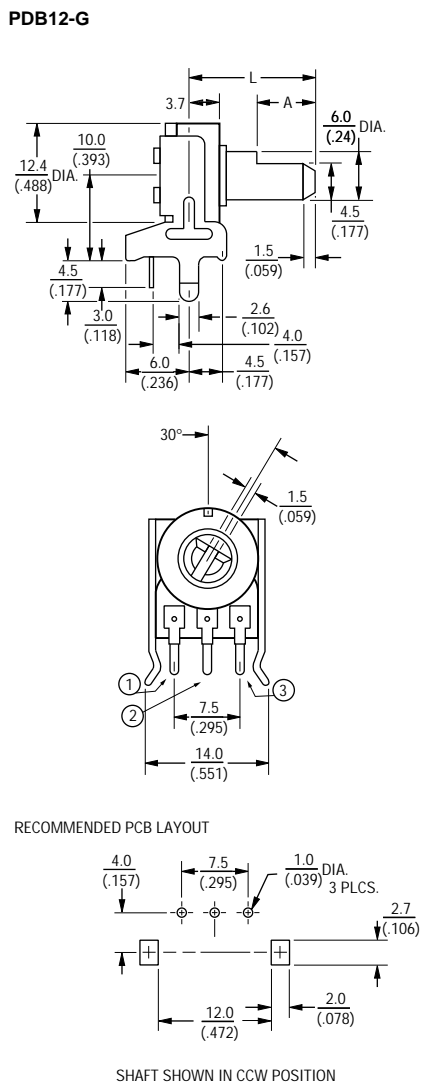

**PDB12-G Dimensions**

L	20	25
	(.787)	(.984)
A	7	12
	(.275)	(.472)

DIMENSIONS ARE:  $\frac{\text{METRIC}}{\text{(INCHES)}}$

# PDB12 Series - 12mm Rotary Potentiometer

# BOURNS®

## Product Dimensions

### PDB12-M

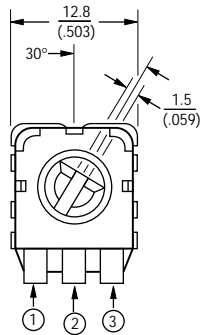
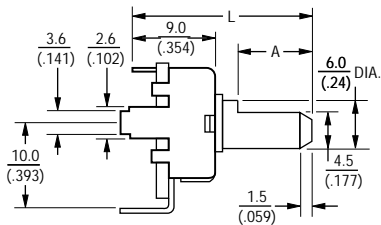

#### RECOMMENDED PCB LAYOUT

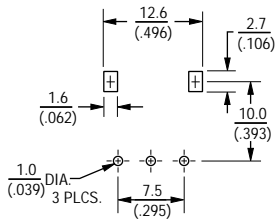

SHAFT SHOWN IN CCW POSITION

### PDB12-M Dimensions

L	20	25
	(.787)	(.984)
A	7	12
	(.275)	(.472)

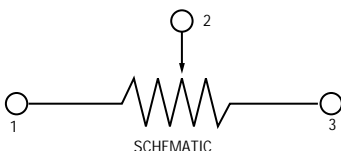

### PDB12-F

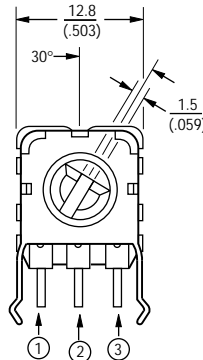
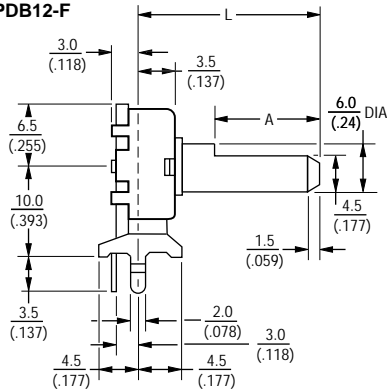

#### RECOMMENDED PCB LAYOUT

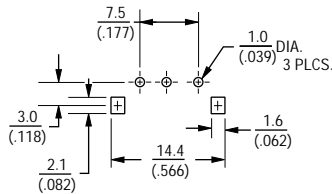

SHAFT SHOWN IN CCW POSITION

### PDB12-F Dimensions

L	20	25
	(.787)	(.984)
A	7	12
	(.275)	(.472)

## How To Order

**PDB12 - H 4 20 1 - 103 A F**

Model \_\_\_\_\_  
 Terminal Config. \_\_\_\_\_  
 (See individual drawings)  
 Option \_\_\_\_\_  
 • 2 = Center Detent  
 • 4 = No Detent  
 Standard Shaft Length \_\_\_\_\_  
 • 20 = 20mm  
 • 25 = 25mm  
 Number of Gangs \_\_\_\_\_  
 • 1 = Single Gang  
 Resistance Code (See Table) \_\_\_\_\_  
 Resistance Taper \_\_\_\_\_  
 • A = Audio Taper  
 • B = Linear Taper  
 Shaft Style \_\_\_\_\_  
 • F = Flat Type Insulated Shaft  
 Other styles available.

## Standard Resistance Table

Resistance (Ohms)	Resistance Code
1,000	102
2,000	202
5,000	502
10,000	103
20,000	203
50,000	503
100,000	104
200,000	204
500,000	504
1,000,000	105

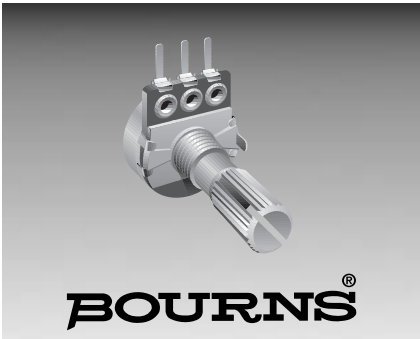

**BOURNS®**

**Features**

- Single and dual section control
- Metal shaft styles
- Carbon element
- Center detent option
- Wide range of resistance tapers

**Applications**

- Audio/TV sets
- Car radio
- Amplifiers/mixers/drum machines/synthesizers
- PCs/monitors
- Appliances

**PDB18 Series - 18mm Rotary Potentiometer**

**Electrical Characteristics**

Taper .....A, B  
 Standard Resistance Range .....1K ohms to 1M ohms  
 Standard Resistance Tolerance .....±20%  
 Standard Nominal Resistance Value .....See standard resistance table  
 Residual Resistance .....Maximum 1%

**Environmental Characteristics**

Power Rating  
 Taper B .....0.2 watt  
 Dual Section .....0.125 watt  
 Taper A .....0.1 watt  
 Dual Section .....0.06 watt  
 Maximum Operating Voltage  
 Taper B .....200 V  
 Taper A .....150 V  
 Sliding Noise .....47mV maximum

**Physical Characteristics**

Mechanical Angle .....300° ±5°  
 Rotational Torque .....50 to 350 gcm  
 Click Torque .....150 to 500 gcm  
 Stop- End Strength .....5 kgcm minimum  
 Rotational Life .....15,000 cycles minimum  
 Soldering Condition .....260°C max.  
 within 3 seconds

**How To Order**

**PDB18 1 - K 4 25 K - 103 A**

Model

Number or Sections  
 • 1 = Single Section  
 • 2 = Dual Section

Terminal Configuration (Pin Layout)  
 • K = PC Pins vertical/Down Facing

Option  
 • 4 = No Center Detent  
 • 2 = Center Detent

Standard Shaft Length  
 • 20 = 20mm  
 • 25 = 25mm

Shaft Style  
 • K = Metal Knurled Type Shaft  
 18 Toothed Serration Type

Resistance Code (See Table)

Resistance Taper  
 • A = Audio Taper  
 • B = Linear Taper

Other styles available.

**Product Dimensions**

**PDB181-K**

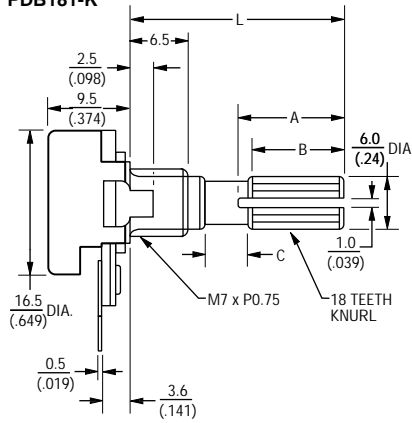

**PDB182-K**

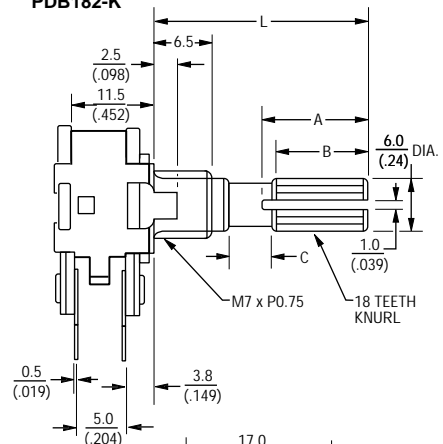

**Standard Resistance Table**

Resistance (Ohms)	Resistance Code
1,000	102
2,000	202
5,000	502
10,000	103
20,000	203
50,000	503
100,000	104
200,000	204
500,000	504
1,000,000	105

DIMENSIONS ARE:  $\frac{\text{METRIC}}{\text{(INCHES)}}$

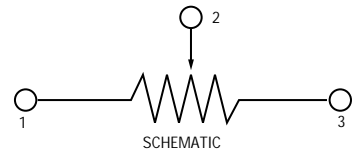

**PDB18 Dimensions**

L	20	25
	(.787)	(.984)
A	12	14
	(.472)	(.551)
B	10	12
	(.393)	(.472)
C	2	2
	(.078)	(.078)



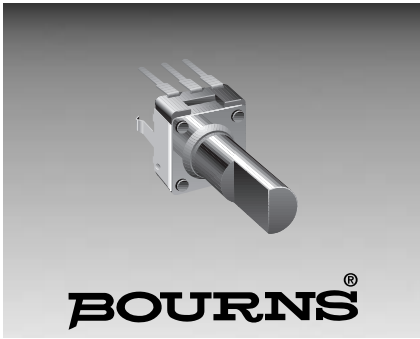

## Features

- Carbon element
- Insulated shaft
- Snap-in clip
- Center detent option

## Applications

- Audio/TV sets
- Car radio
- Amplifiers/mixers/drum machines/synthesizers
- PCs/monitors
- Appliances

# PTV09 Series - 9mm Potentiometer

### Electrical Characteristics

Taper .....A, B  
 Standard Resistance Range .....1K ohms to 1M ohms  
 Standard Resistance Tolerance ....±20%  
 Standard Nominal Resistance Value .....See standard resistance table  
 Residual Resistance .....500 ohms maximum or ±1%

### Environmental Characteristics

Power Rating .....0.05 watt  
 Maximum Operating Voltage .....20 VDC, 50 VAC  
 Sliding Noise .....100mV maximum

### Physical Characteristics

Mechanical Angle .....280° ±5°  
 Rotational Torque.....10 to 100 gcm  
 Click Torque .....40 to 200 gcm  
 Stop- End Strength .....3 kgcm minimum  
 Rotational Life .....10,000 cycles minimum  
 Soldering Condition .....300°C max.  
 within 3 seconds

### How To Order

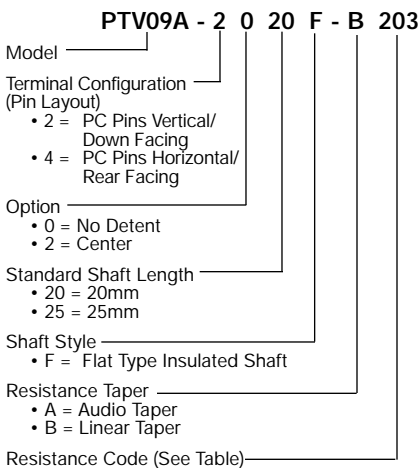

Other styles available.

### Product Dimensions

PTV09A-2

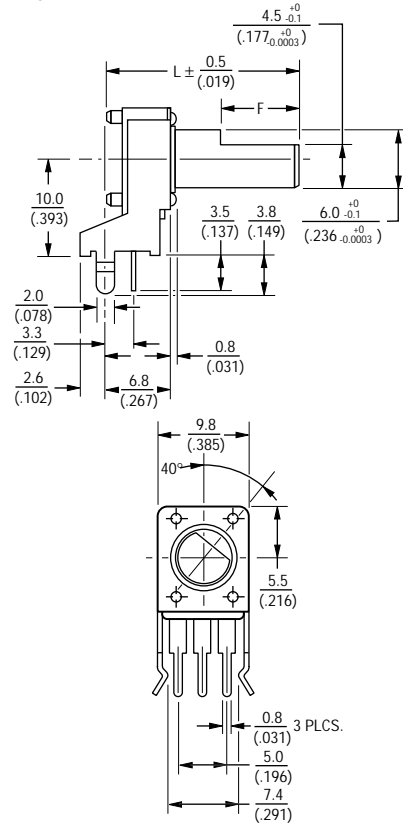

RECOMMENDED PCB LAYOUT

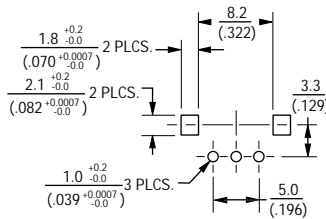

SHAFT SHOWN IN CCW POSITION

### PTV09 Dimensions

L	20	25
	(.787)	(.984)
F	7	12
	(.275)	(.472)

DIMENSIONS ARE: METRIC (INCHES)

PTV09A-4

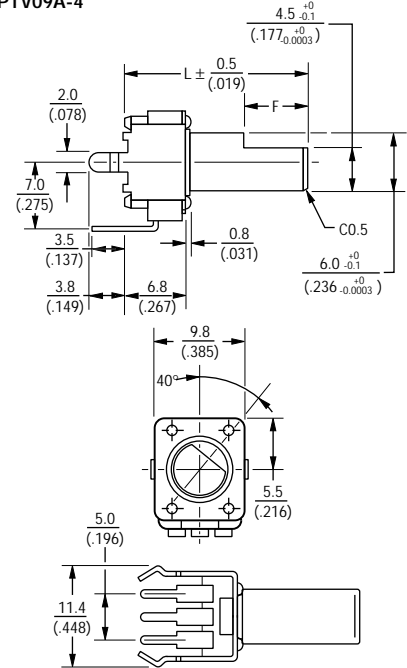

RECOMMENDED PCB LAYOUT

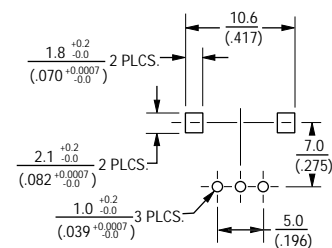

### Standard Resistance Table

Resistance (Ohms)	Resistance Code
1,000	102
2,000	202
5,000	502
10,000	103
20,000	203
50,000	503
100,000	104
200,000	204
500,000	504
1,000,000	105



**BOURNS®**

## Features

- Carbon element
- Insulated shaft
- Snap-in clip
- Center detent
- Center tap option
- Assorted pin layouts

## Applications

- Audio/TV sets
- Car radio
- Amplifiers/mixers/drum machines/synthesizers
- PCs/monitors
- Appliances

# PTV111/PTT111 - 11mm Potentiometer

### Electrical Characteristics

Taper .....A, B  
 Standard Resistance Range .....1K ohms to 1M ohms  
 Standard Resistance Tolerance .....±20%  
 Standard Nominal Resistance Value .....See standard resistance table  
 Residual Resistance .....Maximum 1%

### Environmental Characteristics

Power Rating .....0.05 Watt  
 Maximum Operating Voltage .....50V AC, 20V DC  
 Sliding Noise .....100mV maximum

### Physical Characteristics

Mechanical Angle .....30° ±5°  
 Rotational Torque .....20 to 200 gcm  
 Click Torque .....30 to 300 gcm  
 Stop- End Strength  
 no bushing .....5 kgcm minimum  
 with bushing .....6 kgcm minimum  
 Rotational Life .....10,000 cycles minimum  
 Soldering Condition .....300°C max.  
 within 3 seconds

### Electrical Diagrams

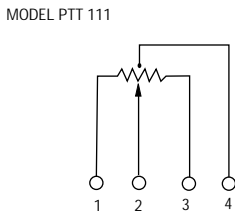
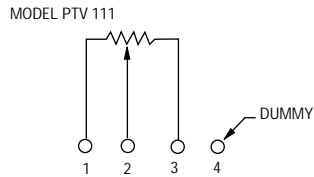

### Product Dimensions

PTV111-2

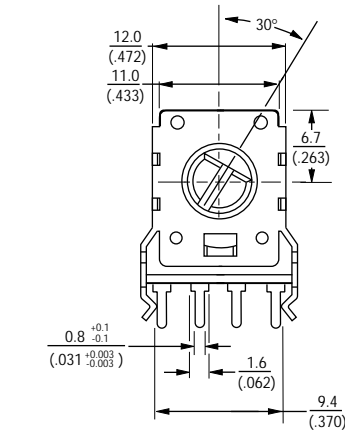
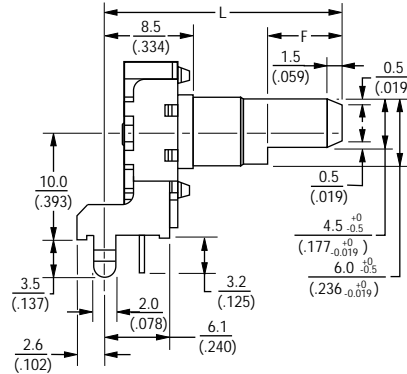

RECOMMENDED PCB LAYOUT

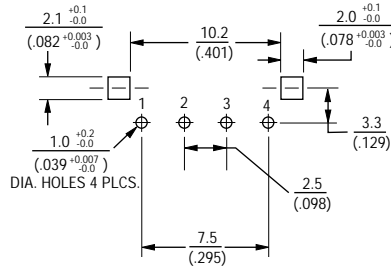

SHAFT SHOWN IN CCW POSITION

PTV111-4

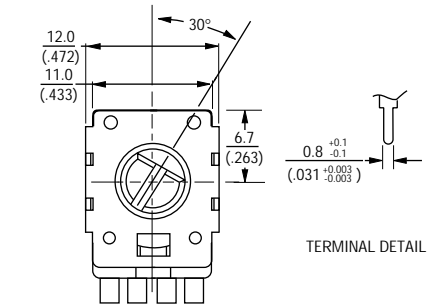
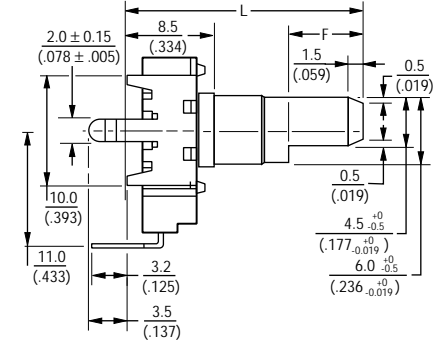

RECOMMENDED PCB LAYOUT

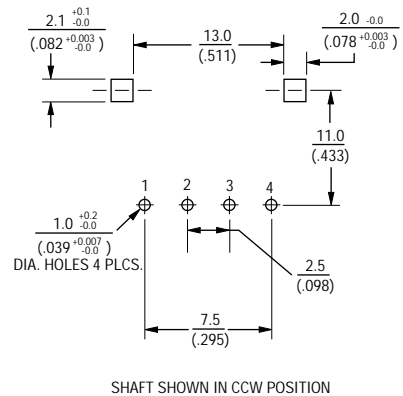

SHAFT SHOWN IN CCW POSITION

### Dimensions Without Bushing

L	20	25
	(.787)	(.984)
F	7	12
	(.275)	(.472)

DIMENSIONS ARE:        METRIC         
       (INCHES)

# PTV111/PTT111 - 11mm Potentiometer



## Product Dimensions

PTV111-1

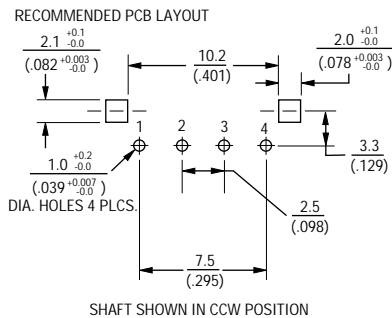
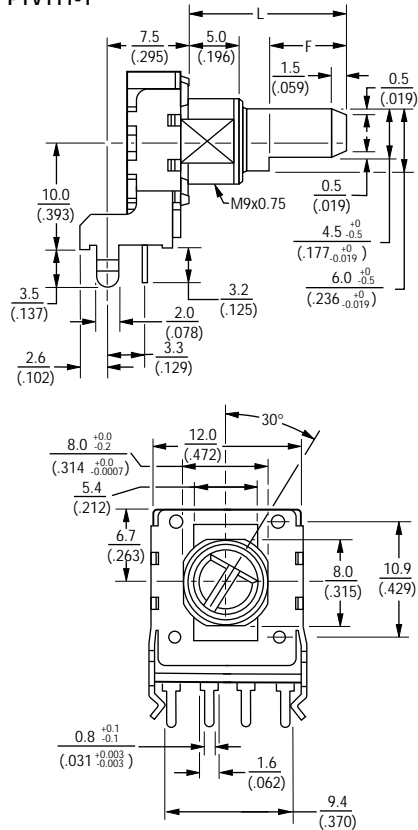

PTV111-3

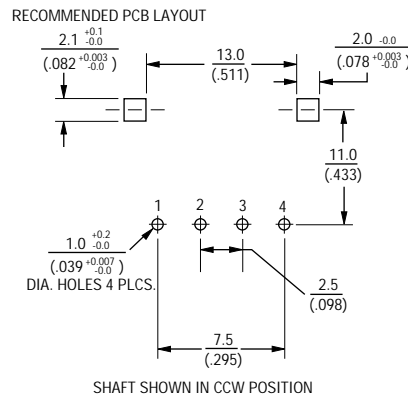
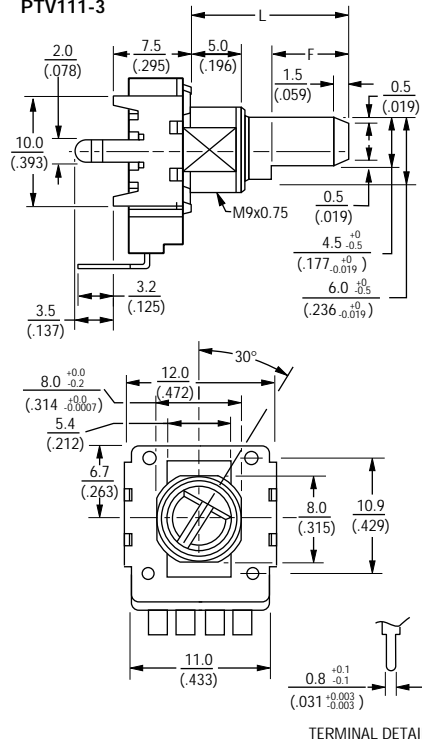

## How To Order

PTV111 - 2 4 20 A - B 104

Model (See Diagrams)

- PTV111 Standard
- PTT111 With Tap

Pin Style

PC Pins vertical/Down Facing:

- 1 = With Bushing
- 2 = No Bushing

PC Pins horizontal/Rear Facing:

- 3 = With Bushing
- 4 = No Bushing

Center Detent Option

- 4 = No Detent
- 2 = Center Detent

Standard Shaft Length

- 15 = 15mm
- 20 = 20mm
- 25 = 25mm

Shaft Styles

- A = Flat Type Insulated Shaft

Resistance Taper

- A = Audio Taper
- B = Linear Taper

Resistance Code (See Table)

Other styles available.

## Standard Resistance Table

Resistance (Ohms)	Resistance Code
1,000	102
2,000	202
5,000	502
10,000	103
20,000	203
50,000	503
100,000	104
200,000	204
500,000	504
1,000,000	105

## Dimensions With Bushing

L	15	20
	(.590)	(.787)
F	7	12
	(.275)	(.472)

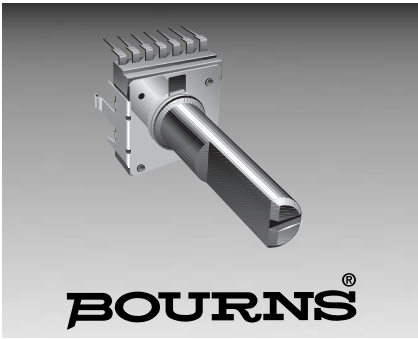

**BOURNS®**

**Features**

- Carbon element
- Insulated shaft
- Snap-in clip
- Center detent option
- Assorted pin layouts

**Applications**

- Audio/TV sets
- Car radio
- Amplifiers/mixers/drum machines/synthesizers
- PCs/monitors
- Appliances

**PTV142 - 14mm Dual Potentiometer**

**Electrical Characteristics**

Taper .....A, B  
 Standard Resistance Range .....1K ohms to 1M ohms  
 Standard Resistance Tolerance .....±20%  
 Standard Nominal Resistance Value .....See standard resistance table  
 Residual Resistance .....500 ohms maximum or 1% of nominal resistance

**Environmental Characteristics**

Power Rating .....0.05 watt  
 Maximum Operating Voltage .....50V AC  
 Sliding Noise .....100mV maximum

**Physical Characteristics**

Mechanical Angle .....300° ±5°  
 Rotational Torque .....20 to 200 gcm  
 Click Torque .....30 to 300 gcm  
 Stop- End Strength .....6 kgcm minimum  
 Rotational Life .... 15,000 cycles minimum  
 Soldering Condition .....300°C max. within 3 seconds

**How To Order**

**PTV142 B - 2 0 E 1 20 A - A 203**

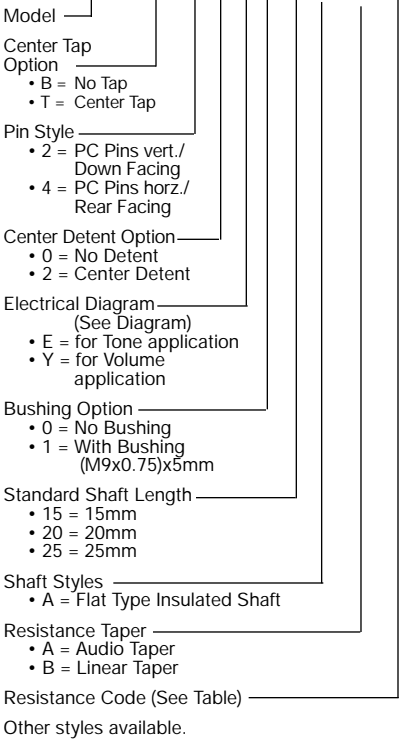

**Product Dimensions**

**PTV142B-2 No Bushing**

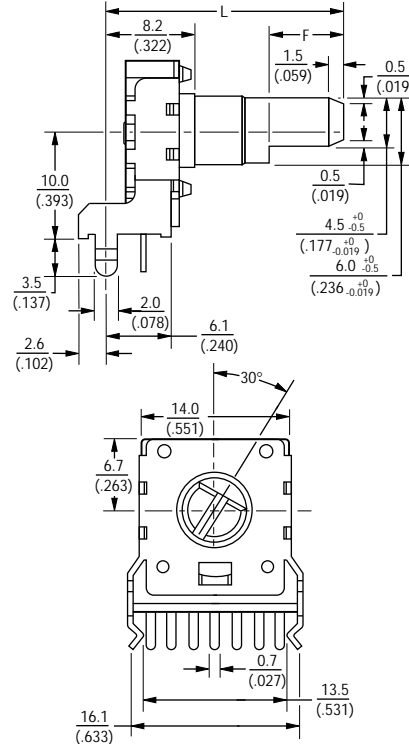

**RECOMMENDED PCB LAYOUT**

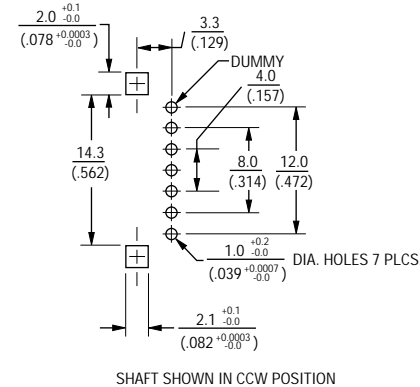

**PTV142B-4 No Bushing**

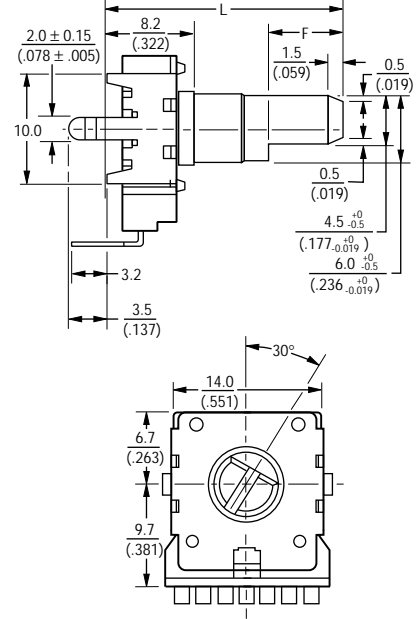

**RECOMMENDED PCB LAYOUT**

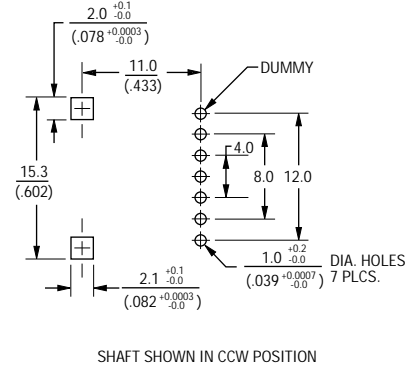

**Dimensions Without Bushing**

L	20	25
	(.787)	(.984)
F	7	12
	(.275)	(.472)

DIMENSIONS ARE: METRIC (INCHES)

# PTV142 - 14MM Dual Potentiometer

## Product Dimensions

PTV142B-2 With Bushing

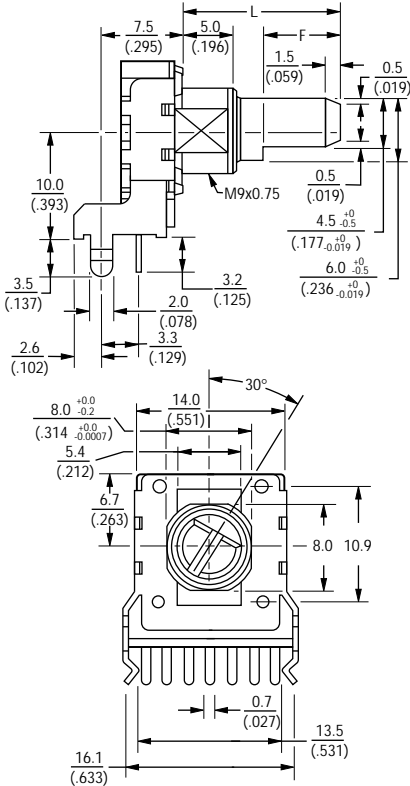

RECOMMENDED PCB LAYOUT

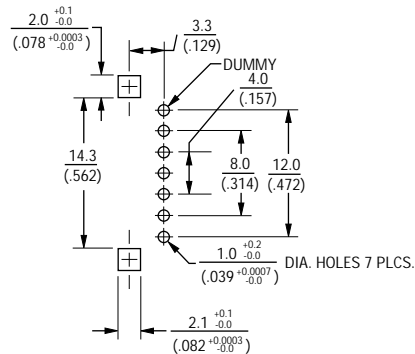

SHAFT SHOWN IN CCW POSITION

PTV142B-4 With Bushing

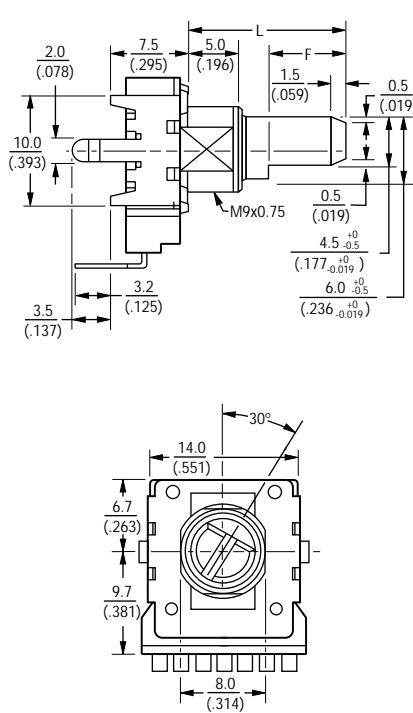

RECOMMENDED PCB LAYOUT

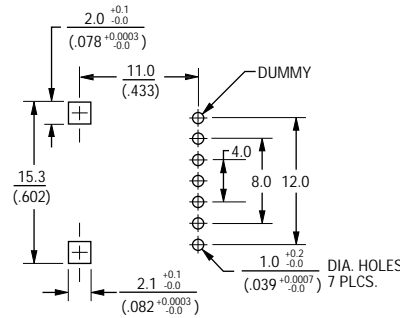

SHAFT SHOWN IN CCW POSITION

## Dimensions Without Bushing

L	15	20
	(.590)	(.787)
F	7	12
	(.275)	(.472)

## Electrical Diagrams

"E" FOR TONE APPLICATION

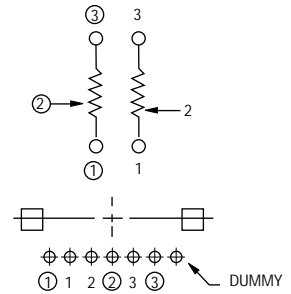

"Y" FOR VOLUME APPLICATION

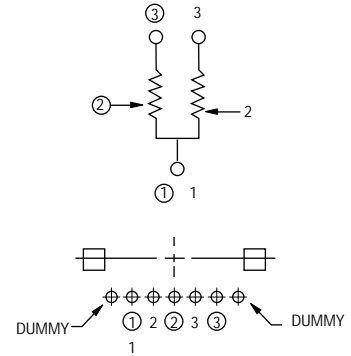

"Y" WITH TAP

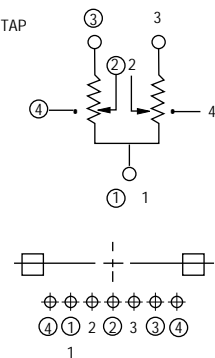

## Standard Resistance Table

Resistance (Ohms)	Resistance Code
1,000	102
2,000	202
5,000	502
10,000	103
20,000	203
50,000	503
100,000	104
200,000	204
500,000	504
1,000,000	105

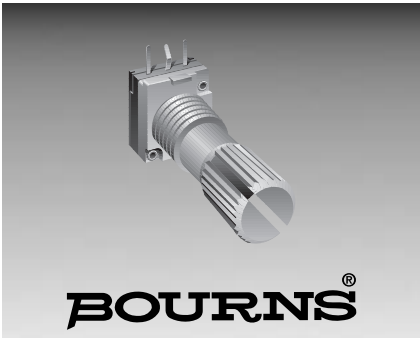

## Features

- Carbon element
- 1 to 4 sections
- Assorted metal shaft styles
- Assortment of resistance tapers
- Tracking error within 3 dB
- Switch option

## Applications

- Audio/TV sets
- Car radio
- Amplifiers/mixers/drum machines/synthesizers
- PCs/monitors
- Appliances

# PTD90/PTR90 - 9mm Multi-Ganged Potentiometer

### Electrical Characteristics

Taper .....A, B  
 Standard Resistance Range .....1K ohms to 1M ohms  
 Standard Resistance Tolerance .....±20%  
 Standard Nominal Resistance Value .....See standard resistance table  
 Residual Resistance .....Maximum 5 ohms between terminals 1&2 and 2&3

### Environmental Characteristics

Power Rating .....0.05 watt  
 Maximum Operating Voltage .....50V AC, 10V DC  
 Tracking Error ..at 50% angle max. ±3dB  
 Sliding Noise.....100mV maximum

### Physical Characteristics

Mechanical Angle .....300° ±5°  
 Rotational Torque.....20 to 200 gcm  
 Stop- End Strength .....4 kgcm minimum  
 Rotational Life ....10,000 cycles minimum  
 Soldering Condition .....300°C max. within 3 seconds

### How To Order

**PTD90 1 - 2 0 20 K - B 203**

Model

- PTD90 = No Switch
- PTR90 = With Rotary Switch

No. of Sections

- 1 = 1 Section
- 2 = 2 Sections
- 4 = 4 Sections

Pin Style

- 2 = PC Pins vertical/Down Facing

Center Detent Option

- 0 = No Detent
- 2 = Center Detent

Standard Shaft Length

- 15 = 15mm
- 20 = 20mm
- 25 = 25mm

Shaft Styles

- K = Knurled Type Shaft (Metal)
- 18 Toothed Serration Type

Resistance Taper

- A = Audio Taper
- B = Linear Taper

Resistance Code (See Table)

Other styles available.

### Product Dimensions

PTD901

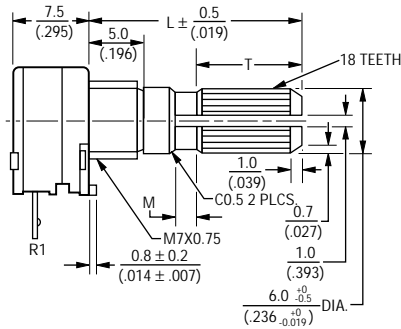

PTD902

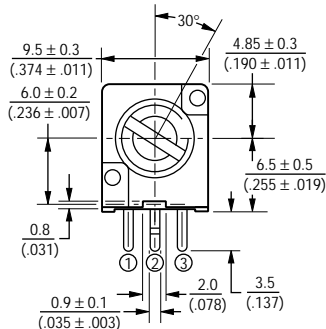
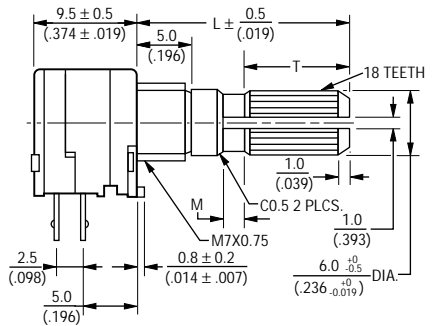

RECOMMENDED PCB LAYOUT

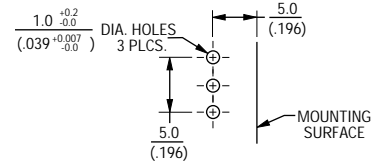

SHAFT SHOWN IN CCW POSITION

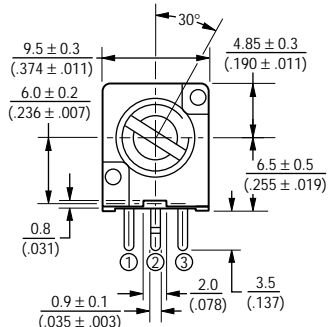

RECOMMENDED PCB LAYOUT

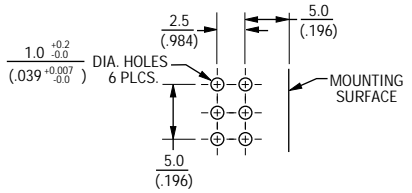

SHAFT SHOWN IN CCW POSITION

### PTD90 Dimensions

L	15	20	25
	(.590)	(.787)	(.984)
T	6	10	12
	(.236)	(.393)	(.472)
M	1.5	2	4
	(.059)	(.078)	(.157)

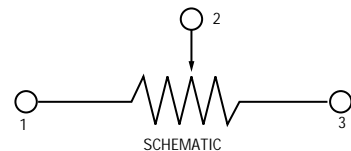

DIMENSIONS ARE: METRIC (INCHES)

# PTD90/PTR90 - 9mm Multi-Ganged Potentiometer

**BOURNS®**

## Product Dimensions

## Standard Resistance Table

PTD904

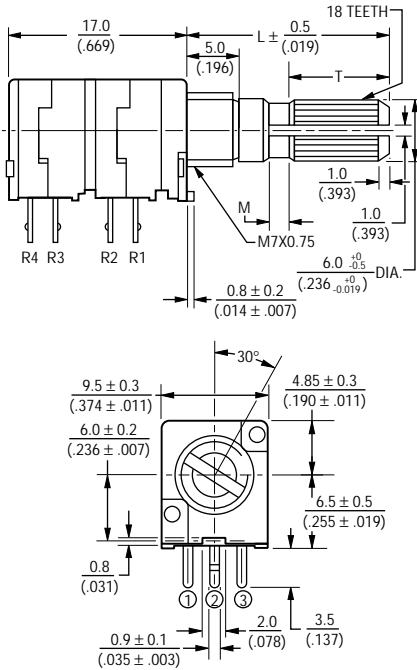

PTR902

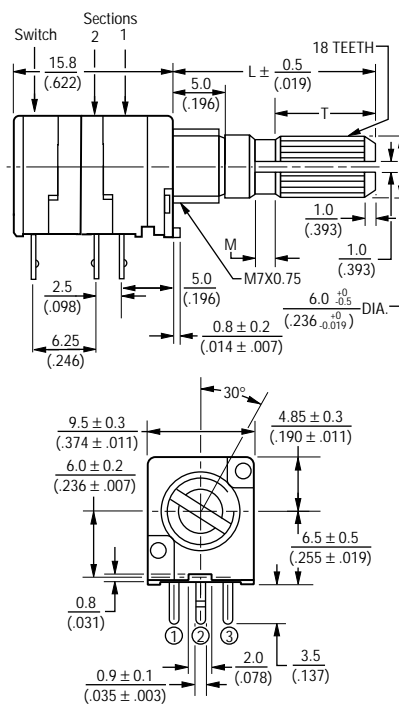

Resistance (Ohms)	Resistance Code
1,000	102
2,000	202
5,000	502
10,000	103
20,000	203
50,000	503
100,000	104
200,000	204
500,000	504
1,000,000	105

RECOMMENDED PCB LAYOUT

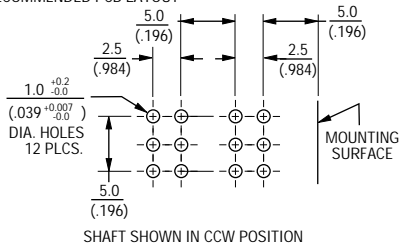

RECOMMENDED PCB LAYOUT

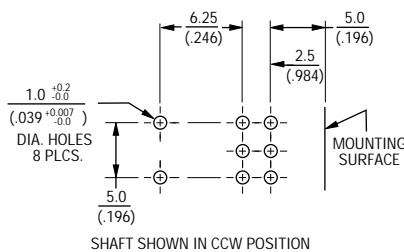

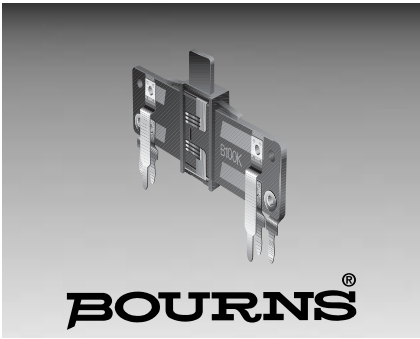

**BOURNS®**

### Features

- Carbon element
- 10-30mm travel
- Center detent option
- Single or dual gang

### Applications

- Audio/TV sets
- Car radio
- Amplifiers/mixers/drum machines/synthesizers
- PCs/monitors
- Appliances

## PDV Series - Open Frame Slide Potentiometer

#### Electrical Characteristics

Taper .....A, B  
 Standard Resistance Range .....1K ohms to 1M ohms  
 Standard Nominal Resistance Value .....See standard resistance table  
 Residual Resistance .....100 ohms maximum or ±5%

#### Environmental Characteristics

Power Rating  
 Taper B .....0.1 watt  
 Taper A .....0.05 watt  
 Maximum Operating Voltage  
 Taper B .....150 V  
 Taper A .....100 V  
 Sliding Noise .....47mV maximum

#### Physical Characteristics

Standard Stroke Length .....10, 15, 20, 30mm  
 Sliding Force .....20 to 300 gcm  
 Click Torque .....50 to 400 gcm  
 Stop- End Strength .....3 kgcm minimum  
 Sliding Life .....10,000 cycles minimum  
 Soldering Condition .....260°C max. within 3 seconds

#### How To Order

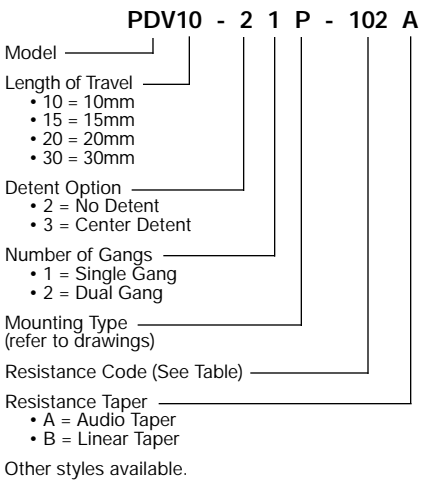

#### Product Dimensions

PDVxx-x1D

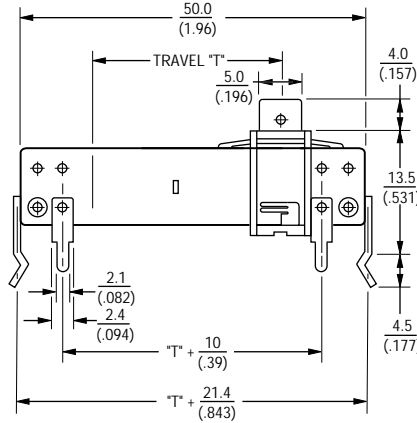

PDVxx-x2D

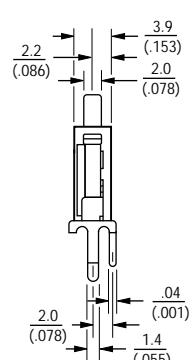
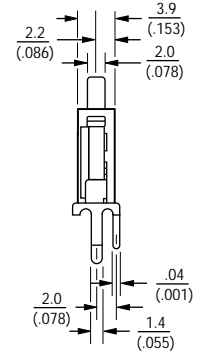
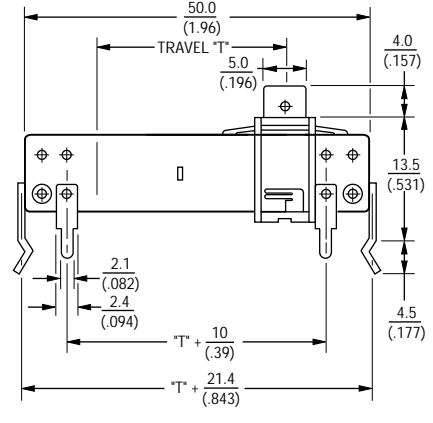

RECOMMENDED PCB LAYOUT

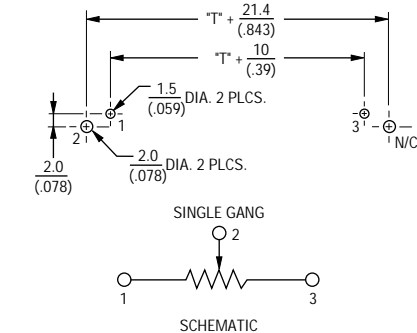

RECOMMENDED PCB LAYOUT

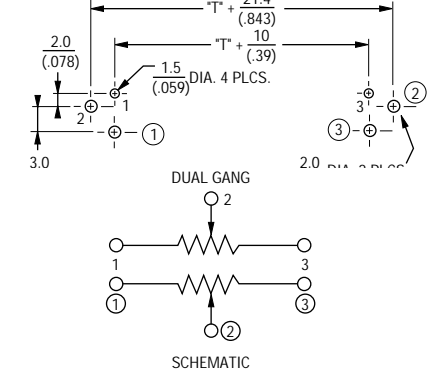

DIMENSIONS ARE: METRIC  
(INCHES)



# PDV Series - Open Frame Slide Potentiometer



## Product Dimensions

PDVxx-x1P

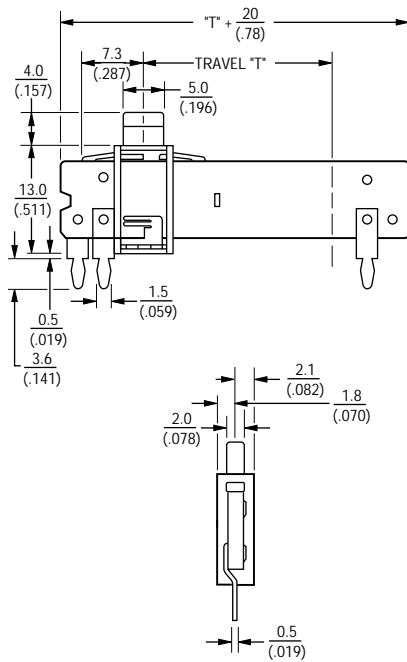

PDVxx-x2P

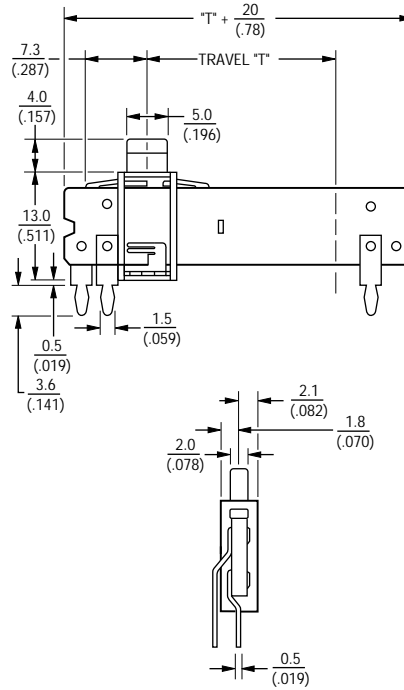

RECOMMENDED PCB LAYOUT

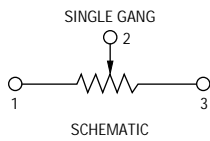
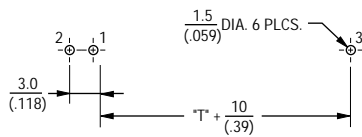

RECOMMENDED PCB LAYOUT

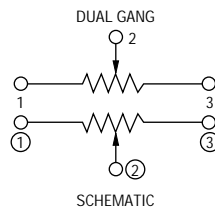
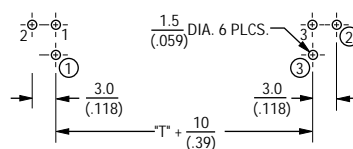

## Standard Resistance Table

Resistance (Ohms)	Resistance Code
1,000	102
2,000	202
5,000	502
10,000	103
20,000	203
50,000	503
100,000	104
200,000	204
500,000	504
1,000,000	105



## Features

- Carbon element
- Metal housing
- 15-60mm travel
- Single and dual gang
- Center detent option
- Dust cover option

## Applications

- Audio/TV sets
- Car radio
- Amplifiers/mixers/drum machines/synthesizers
- PCs/monitors
- Appliances

# PTA Series - Low Profile Slide Potentiometer

### Electrical Characteristics

Taper .....A, B  
 Standard Resistance Range  
 .....1K ohms to 1M ohms  
 Standard Nominal Resistance Value  
 .....See standard resistance table  
 Standard Resistance Tolerance .....±20%  
 Residual Resistance  
 .....500 ohms maximum or 1%  
 Insulation Resistance  
 .....Min. 100 megohms at 250V DC

### Environmental Characteristics

**Power Rating, B Taper**  
 15mm .....0.05W (0.025W Dual Gang)  
 20mm .....0.1W (0.05W)  
 30mm .....0.2W (0.1W)  
 45mm .....0.25W (0.125W)  
 60mm .....0.25W (0.125W)

**Power Rating, A Taper**  
 15mm .....0.025W (0.015W Dual Gang)  
 20mm .....0.05W (0.025W)  
 30mm .....0.1W (0.05W)  
 45mm .....0.125W (0.06W)  
 60mm .....0.125W (0.06W)

**Rated Voltage, B Taper**  
 15mm .....100V DC  
 20-60mm .....200V DC

**Rated Voltage, A Taper**  
 15mm .....50V DC  
 20-60mm .....150V DC

**Withstand Voltage, A Taper** .....1 Min.  
 at 300V AC

**Tracking Error** .....3 dB at -40 to 0 dB

**Sliding Noise** .....100mV maximum

### Physical Characteristics

Travel .....15, 20, 30, 45, 60mm  
 Operating Force .....30 to 250 gcm  
 Lever Stop Strength .....5 kgcm min.  
 Rotational Life ....15,000 cycles minimum  
 Soldering Condition .....300°C max.  
 within 3 seconds

### Lever Style & Product Dimensions

Actuator Styles

DP METAL LEVER

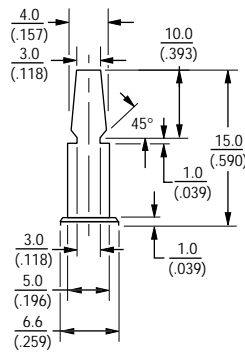

CP METAL LEVER

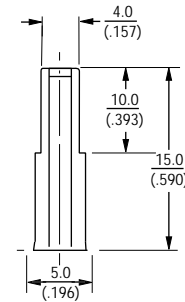

CI INSULATED LEVER

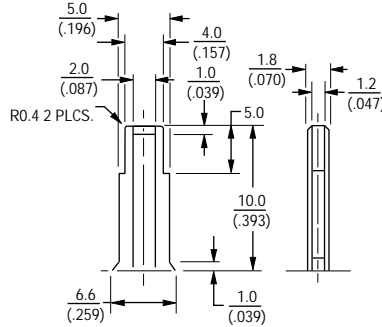

DIMENSIONS ARE: METRIC  
 (INCHES)

### How To Order

PTA 15 4 3 - 2 0 10 DP - B 203

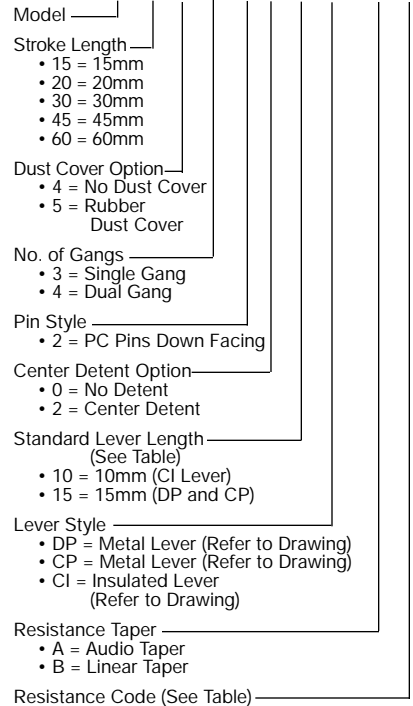

Other styles available

### Standard Resistance Table

Resistance (Ohms)	Resistance Code
1,000	102
2,000	202
5,000	502
10,000	103
20,000	203
50,000	503
100,000	104
200,000	204
500,000	504
1,000,000	105

# PTA Series - Low Profile Slide Potentiometer



## Product Dimensions

PTAxx43

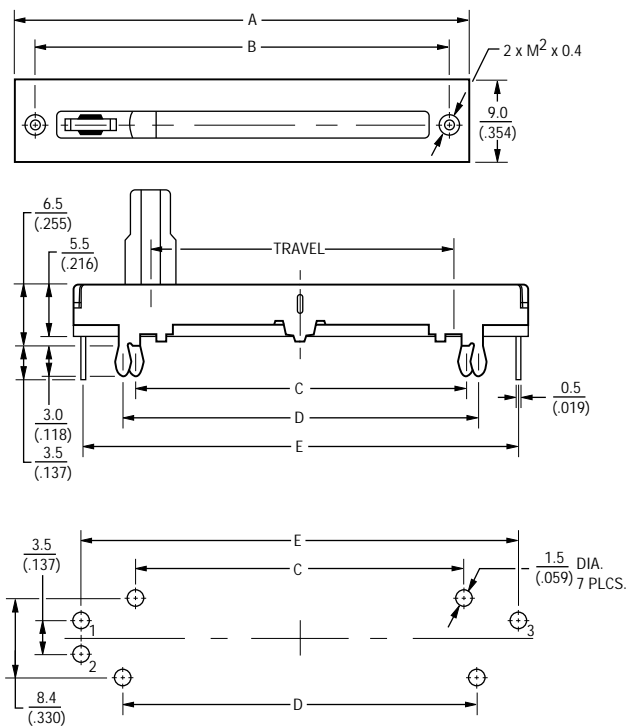

PTAxx44

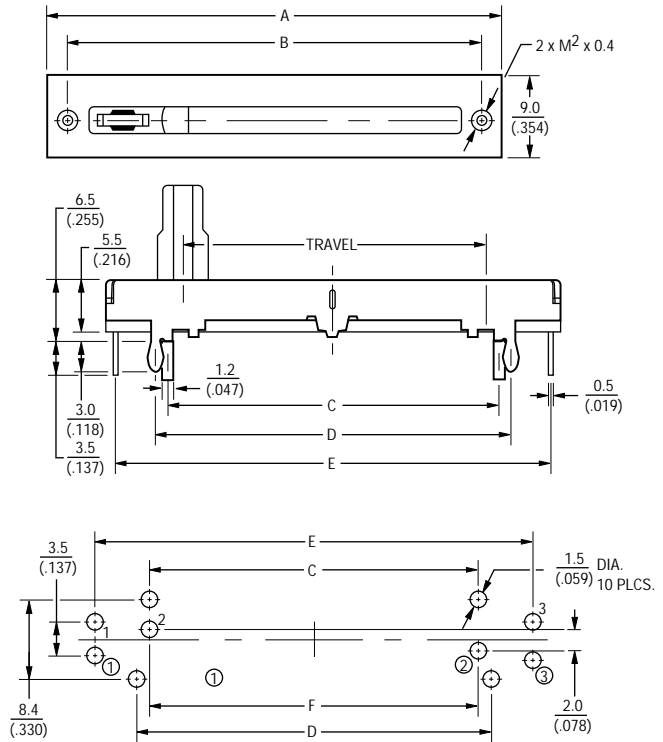

## Single Gang Dimensions

Model	A	B	C	D	E	Travel
PTA1543	30 (3.18)	26 (1.02)	17.8 (.700)	20.2 (.795)	28.5 (1.12)	15mm (.59)
PTA2043	35 (1.37)	31 (1.22)	22.8 (.897)	25.2 (.992)	33.5 (1.31)	20mm (.787)
PTA3043	45 (1.77)	41 (1.61)	32.8 (1.29)	35.2 (1.38)	43.5 (1.71)	30mm (1.18)
PTA4543	60 (2.36)	56 (2.20)	47.8 (1.88)	50.2 (1.97)	58.5 (2.30)	45mm (1.77)
PTA6043	75 (2.95)	71 (2.79)	62.8 (2.47)	65.2 (2.56)	73.5 (2.89)	60mm (2.36)

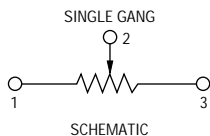

## Dual Gang Dimensions

Model	A	B	C	D	E	F	Travel
PTA1544	30 (3.18)	26 (1.02)	17.8 (.700)	20.2 (.795)	28.5 (1.12)	18 (.708)	15mm (.59)
PTA2044	35 (1.37)	31 (1.22)	22.8 (.897)	25.2 (.992)	33.5 (1.31)	23 (.905)	20mm (.787)
PTA3044	45 (1.77)	41 (1.61)	32.8 (1.29)	35.2 (1.38)	43.5 (1.71)	33 (1.29)	30mm (1.18)
PTA4544	60 (2.36)	56 (2.20)	47.8 (1.88)	50.2 (1.97)	58.5 (2.30)	48 (1.88)	45mm (1.77)
PTA6044	75 (2.95)	71 (2.79)	62.8 (2.47)	65.2 (2.56)	73.5 (2.89)	63 (2.48)	60mm (2.36)

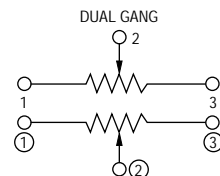



**BOURNS**<sup>®</sup>

## Features

- Carbon element
- Metal housing
- 45 - 100mm travel
- Single and dual gang
- Dust cover option

## Applications

- Audio/TV sets
- Car radio
- Amplifiers/mixers/drum machines/synthesizers
- PCs/monitors
- Appliances

# PTB Series - Low Profile Slide Potentiometer

### Electrical Characteristics

Taper .....A, B  
 Standard Resistance Range  
 .....1K ohms to 1M ohms  
 Standard Nominal Resistance Value  
 .....See standard resistance table  
 Standard Resistance Tolerance .....±20%  
 Residual Resistance  
 .....500 ohms maximum or 1%  
 Insulation Resistance  
 .....Min. 100 megohms at 250V DC

### Environmental Characteristics

Power Rating, B Taper  
 45mm .....0.125W (0.06W Dual Gang)  
 60mm .....0.25W (0.125W)  
 100mm .....0.5W (0.5W)  
 Power Rating, A Taper  
 45mm .....0.025W (0.015W Dual Gang)  
 60mm .....0.25W (0.125W)  
 100mm .....0.25W (0.25W)  
 Rated Voltage, B Taper  
 45mm .....350V DC  
 60-100mm .....500V DC  
 Rated Voltage, A Taper  
 45mm .....250V DC  
 60-100mm .....350V DC  
 Withstand Voltage, A Taper .....1 Min.  
 at 500V AC  
 Tracking Error .....3 dB at -40 to 0 dB

### Physical Characteristics

Travel.....45, 60, 100mm  
 Operating Force.....50 to 350 gcm  
 Lever Stop Strength .....5 kgcm min.  
 Rotational Life .... 15,000 cycles minimum  
 Soldering Condition .....300°C max.  
 within 3 seconds

### Product Dimensions

#### PTB45 and PTB60

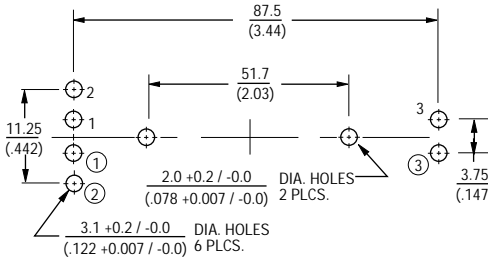
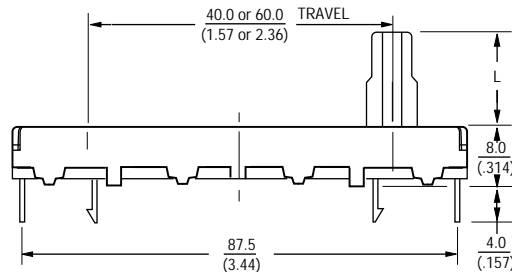
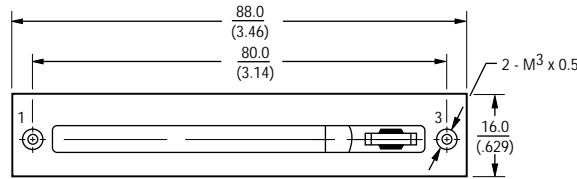

Numbers ①, ② and ③ for Dual Gang Versions

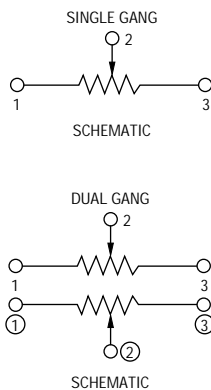

Lever Style  
BP Metal Lever

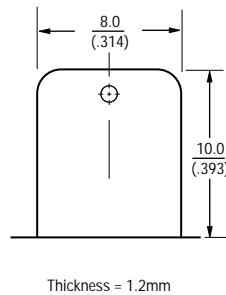

AP Metal Lever

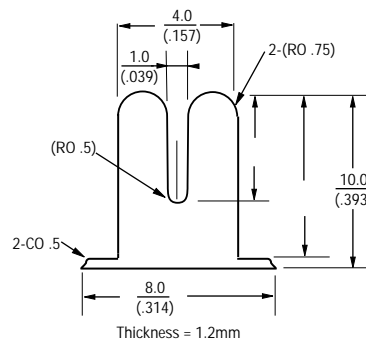

DIMENSIONS ARE: METRIC  
(INCHES)

# PTB Series - Low Profile Slide Potentiometer



## Product Dimensions

PTB01

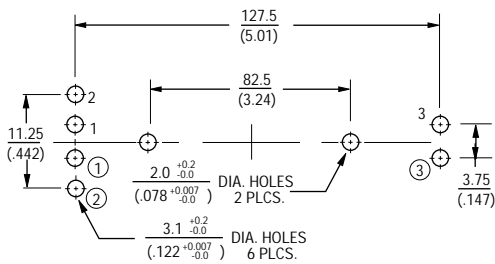
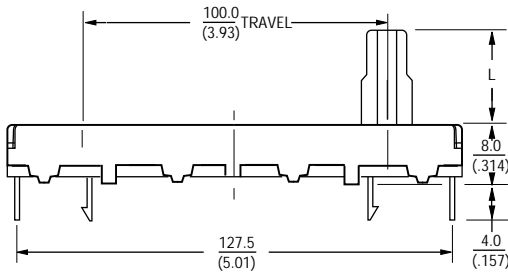
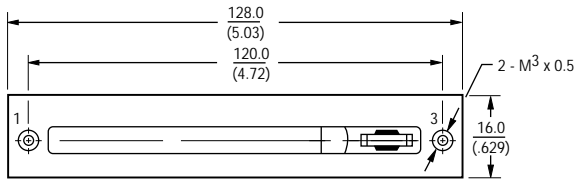

Numbers ①, ② and ③ for Dual Gang Versions

## How To Order

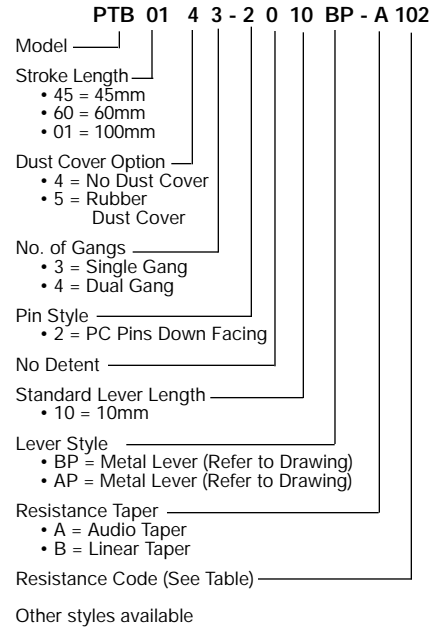

## Standard Resistance Table

Resistance (Ohms)	Resistance Code
1,000	102
2,000	202
5,000	502
10,000	103
20,000	203
50,000	503
100,000	104
200,000	204
500,000	504
1,000,000	105

# Taper Characteristics

**BOURNS®**

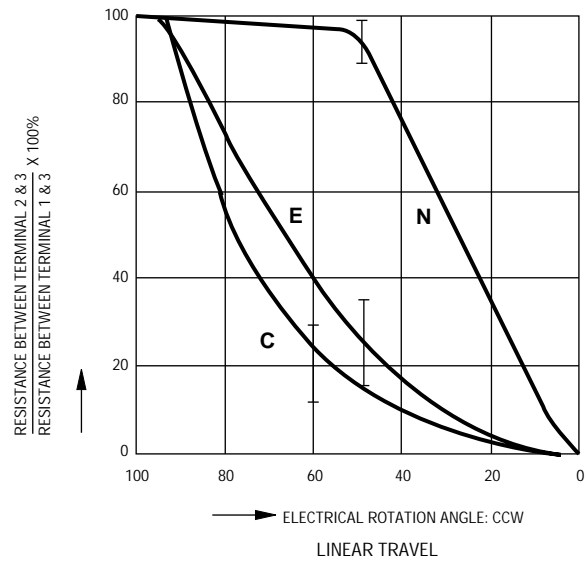
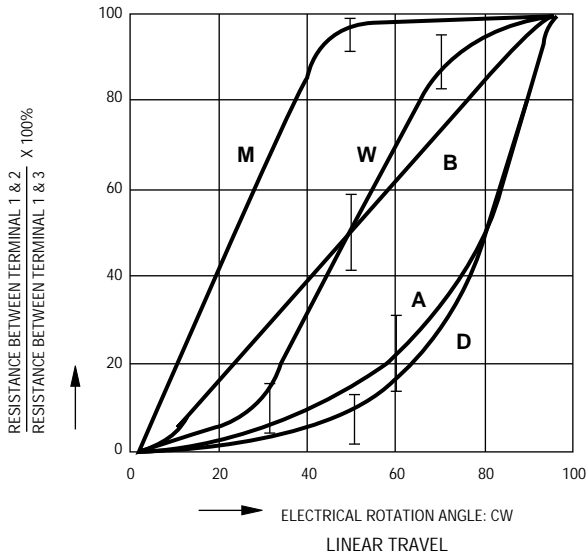

## TEST METHOD

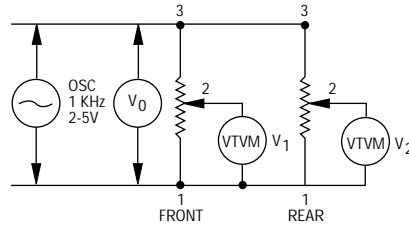

$$\text{GANG ERROR: } 20 \text{ LOG } \frac{V_2}{V_1} \text{ (dB)}$$

$$\text{ATTENUATION: } 20 \text{ LOG } \frac{V_1 \text{ OR } V_2}{V_0} \text{ (dB)}$$