

# 10G 1550nm XFP Transceiver

(Up to 40km transmission)

## Members of Flexon™ Family



- ◆ Compliant with FCC 47 CFR Part 15, Class B
- ◆ Compliant with FDA 21 CFR 1040.10 and 1040.11, Class I
- ◆ RoHS compliance

## Description

FTM-53X0C-X40G is a high performance, cost effective modules, which is optimized for 10G Ethernet, supporting data-rate of 10.3125Gbps (10GBASE-ER) or 9.953Gbps (10GBASE-EW), and transmission distance up to 40km.

The transceiver consists of two sections: The transmitter section incorporates a 1550nm cooled EML, driver and re-timer. The receiver section consists of a PIN photodiode integrated with a transimpedance preamplifier (TIA) and CDR.

The module is hot pluggable into the 30-pin connector. The high-speed electrical interface is base on low voltage logic, with nominal 100 Ohms differential impedance and AC coupled in the module. The optical output can be disabled by LVTTTL logic high-level input of TX\_DIS. Loss of signal (RX\_LOS) output is provided to indicate the loss of an input optical signal of receiver.

A serial EEPROM in the transceiver allows the user to access transceiver monitoring and configuration data via the 2-wire XFP Management Interface. This interface uses a single address, A0h, with a memory map divided into a lower and upper area. Basic digital diagnostic (DD) data is held in the lower area while specific data is held in a series of tables in the high memory area.

## Features

- ◆ Support 10GE application at the data-rate of 10.3125Gbps and 9.953Gbps
- ◆ Up to 40km transmission
- ◆ 1550nm cooled EML and PIN receiver
- ◆ XFI electrical interface
- ◆ 2-wire interface for integrated Digital Diagnostic monitoring
- ◆ XFP MSA package with duplex LC connector
- ◆ Hot pluggable
- ◆ Very low EMI and excellent ESD protection
- ◆ +5V, +3.3V power supply
- ◆ Power consumption less than 3.5 W

## Applications

- ◆ 10GBASE-ER at 10.3125Gbps
- ◆ 10GBASE-EW at 9.953Gbps
- ◆ Other optical links

## Standard

- ◆ Compliant with XFP MSA
- ◆ Compliant with IEEE 802.3ae-2002

## Regulatory Compliance

The transceivers are tested according to American and European product safety and electromagnetic compatibility regulations (See Table 1). For further information regarding regulatory certification, please refer to Fiberxon regulatory specification and safety guidelines, or contact with Fiberxon, Inc. America sales office listed at the end of the documentation.

**Table 1- Regulatory Compliance**

Feature	Standard	Performance
Electrostatic Discharge (ESD) to the Electrical Pins	MIL-STD-883E Method 3015.7	Class 1(>500 V)
Electrostatic Discharge (ESD) to the Duplex LC Receptacle	IEC 61000-4-2 GR-1089-CORE	Compliant with standards
Electromagnetic Interference (EMI)	FCC Part 15 Class B EN55022 Class B (CISPR 22B) VCCI Class B	Compliant with standards
Immunity	IEC 61000-4-3	Compliant with standards
Laser Eye Safety	FDA 21CFR 1040.10 and 1040.11 EN60950, EN (IEC) 60825-1,2	Compliant with Class 1 laser product. TUV certificate No. 50085781
Component Recognition	UL and CSA	UL file E223705

## Absolute Maximum Ratings

Stress in excess of the maximum absolute ratings can cause permanent damage to the module.

**Table 2 - Absolute Maximum Ratings**

Parameter	Symbol	Min.	Max.	Unit
Storage Temperature	$T_S$	-40	+85	°C
Supply Voltage	$V_{CC5}$	-0.5	6.0	V
	$V_{CC3}$	-0.5	4.0	V
Operating Relative Humidity	RH		85	%

## Recommended Operating Conditions

**Table 3 - Recommended Operating Conditions**

Parameter		Symbol	Min.	Typical	Max.	Unit
Operating Temperature	Case Standard	$T_C$	0		+70	°C
	Extended		-40		+70	
Power Supply Voltage		$V_{CC5}$	4.75	5.0	5.25	V
		$V_{CC3}$	3.13	3.3	3.47	
Power Supply Current		$I_{CC5}$			200	mA
		$I_{CC3}$			750	mA
Power Dissipation		$P_D$			3.5	W
Data Rate				9.953/10.3125		Gbps

## Optical Characteristics

**Table 4 - Optical Characteristics**

Parameter	Symbol	Min.	Typical	Max.	Unit	Notes
<b>Transmitter</b>						
Operating Data Rate			9.953/ 10.3125		Gbps	
Centre Wavelength	$\lambda_C$	1530		1565	nm	
Average Output Power	$P_{OUT}$	-4.7		4.0	dBm	1
Optical Modulation Amplitude	OMA	-2.1			dBm	1
Spectral Width	$\Delta\lambda$			1	nm	
Side Mode Suppression Ratio	SMSR	30			dB	
Extinction Ratio	ER	6	8		dB	2
Dispersion Penalty	DP			3.0	dB	2
Optical Eye Mask	Compliant with ITU-T G.691 and GR-253-CORE					
<b>Receiver</b>						
Operating Data Rate			9.953/ 10.3125		Gbps	
Centre Wavelength	$\lambda_C$	1530		1565	nm	
Receiver Sensitivity	$P_{IN}$			-15.8	dBm	3
Receiver Overload	$P_{IN}$	-1			dBm	3
LOS Assert	$LOS_A$	-25			dBm	
LOS Deassert	$LOS_D$			-16	dBm	
LOS Hysteresis		1		4	dB	
Receiver Reflectance				-26	dB	

**Notes:**

1. The optical power is launched into SMF.
2. Measured with a PRBS  $2^{31}-1$  test pattern @10.3125Gbps.
3. Measured with a PRBS  $2^{31}-1$  test pattern @10.3125Gbps,  $BER \leq 10^{-12}$ .

## Electrical Characteristics

**Table 5 - Electrical Characteristics**

Parameter	Symbol	Min.	Typical	Max.	Unit	Notes
<b>High-speed Signal (CML) Interface Specification</b>						
Input Data Rate			9.953/ 10.3125		Gbps	
Differential Data Input Amplitude		120		1000	mVpp	1
Input Differential Impedance			100		$\Omega$	
Output Data Rate			9.953/ 10.3125		Gbps	
Differential Data Output Amplitude		500		800	mVpp	1
Output Differential Impedance			100		$\Omega$	
<b>Low-speed Signal (LVTTTL) Interface Specification</b>						
Input High Voltage		2.0		Vdd1=3.3	V	
Input Low Voltage		GND		0.8	V	
Output High Voltage		2.4		Vdd1=3.3	V	
Output Low Voltage		GND		0.4	V	
<b>2 Wire Serial Interface (LVTTTL) Specification</b>						
Clock Frequency	$f_{SCL}$			400	kHz	
<b>Reference Clock (PECL) Interface Specification</b>						
<b>No reference clock needed</b>						

Note:

- Internally AC coupled

## Management Interface

The structure of the memory map is shown in Figure 1, which is accessible over a 2 wire serial interface at the 8-bit address 1010000X (A0h). The normal 256 Byte I2C address space is divided into lower and upper blocks of 128 Bytes. The lower block of 128 Bytes is always directly available and is used for the diagnostics and control function. The monitoring specification is shown in Table 6. Multiple blocks of memories are available in the upper 128 Bytes of the address space. These are individually addressed through a table select Byte which the user enters into a location in the lower address space. Thus, there is a total available address space of 128 \* 256 = 32Kbytes in this upper memory space. The contents of Table 01h are list in table 7 below. PLS refer INF-8077i (Revision 4.0) for detailed information.

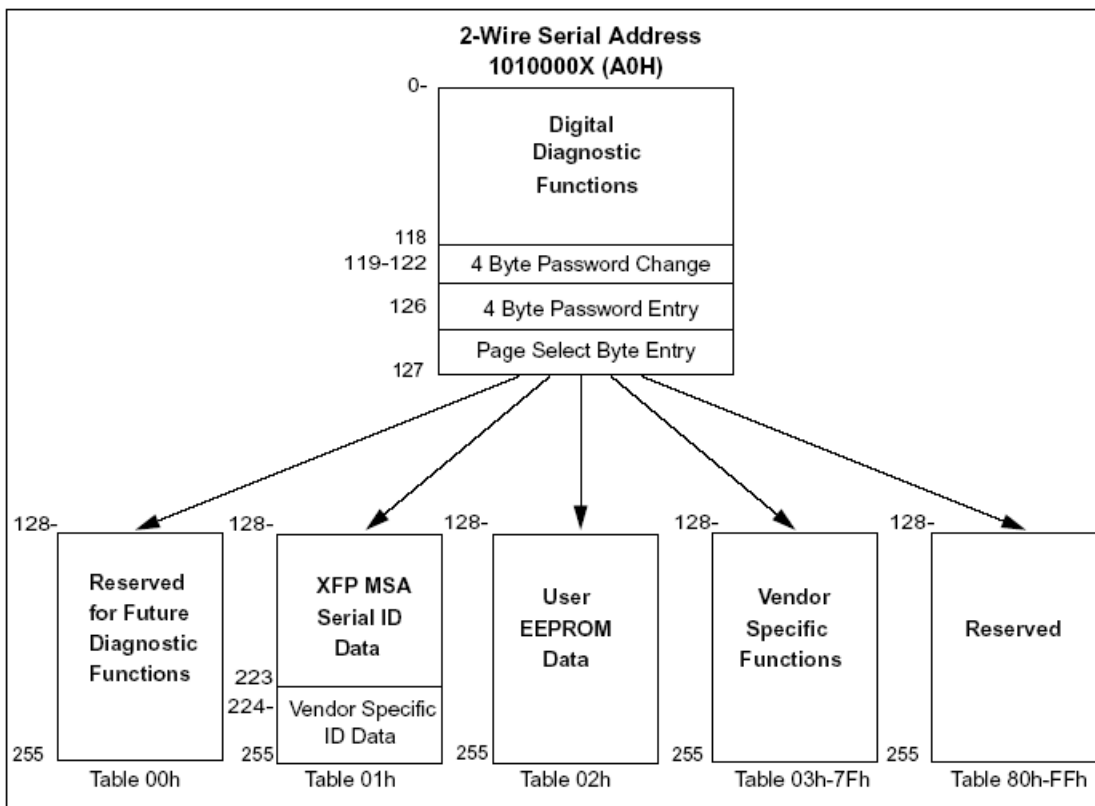

Figure 1, 2-wire Serial Digital Diagnostic Memory Map

Table 6 - Monitoring Specification

Data Address	Parameter	Range	Accuracy
96-97	Temperature	-10 to +80°C (Standard)	±3°C
		-40 to +80°C (Extended)	
100-101	Bias Current	0 to 100mA	±10%
102-103	TX Power	-6 to +5dBm	±2dB
104-105	RX Power	-18 to 0dBm	±2dB
106-107	V <sub>CC5</sub> Voltage	+4.5V to +5.5V	±3%
108-109	V <sub>CC3</sub> Voltage	+3.0V to +3.7V	±3%

**Table 7 - Serial ID Memory Contents (Table 01h)**

Addr.	Field Size (Bytes)	Name of Field	Hex	Description
128	1	Identifier	06	XFP
129	1	Ext. Identifier	50	TX Ref Clock Input not Required
130	1	Connector	07	LC Connector
131-138	8	Transceiver	22 00 00 00 00 00 00 00	10GBASE-ER/W
139	1	Encoding	10	NRZ
140	1	BR-Min	63	9.953Gbps
141	1	BR-Max	71	11.3Gbps
142	1	Length (SMF)-km	28	40km
143	1	Length (E-50um)	00	
144	1	Length (50um)	00	
145	1	Length (62.5um)	00	
146	1	Length (copper)	00	
147	1	Device Tech	74	Cooled1550nm EML, PIN Detector
148-163	16	Vendor name	46 49 42 45 52 58 4F 4E 20 49 4E 43 2E 20 20 20	"FIBERXON INC." (ASC II)
164	1	CDR Support	F8	CDR supports 9.953Gbps~11.1Gbps
165-167	3	Vendor OUI	00 00 00	
168-183	16	Vendor PN	46 54 4D 2D 35 33 58 30 43 2D 58 34 30 47 20 20	"FTM-53X0C-X40G" (ASC II)
184-185	2	Vendor rev	xx xx	ASC II ( "32 61" means 2a revision)
186-187	2	Wavelength	79 18	1550nm
188-189	2	Wavelength Tolerance	0D AC	+/-17.5nm
190	1	Max Case Temp	46	70degC
191	1	CC_BASE		Check sum of bytes 128 - 190
192-195	4	Power Supply	AF 96 AA 00	3.5W (max), 1.5W (max, power down mode), 500mA(max, +5.0V), 1000mA (max, +3.3V)
196-211	16	Vendor SN	xx xx xx xx xx xx xx xx xx xx xx xx xx xx xx xx	ASC II .
212-219	8	Vendor date code	xx xx xx xx xx xx 20 20	Year (2 bytes), Month (2 bytes), Day (2 bytes)
220	1	Diagnostic type	08	No BER Support, Average Power
221	1	Enhanced option	60	Optional Soft Tx_Disable and P_Down
222	1	Aux Monitoring	67	+5.0V and +3.3V Supply Voltage
223	1	CC EXT	xx	Check sum of bytes 192 - 222
224-255	32	Vendor specific		Reserved By Vendor

### Recommended Host Board Power Supply Circuit

Figure 2 shows the recommended host board power supply circuit.

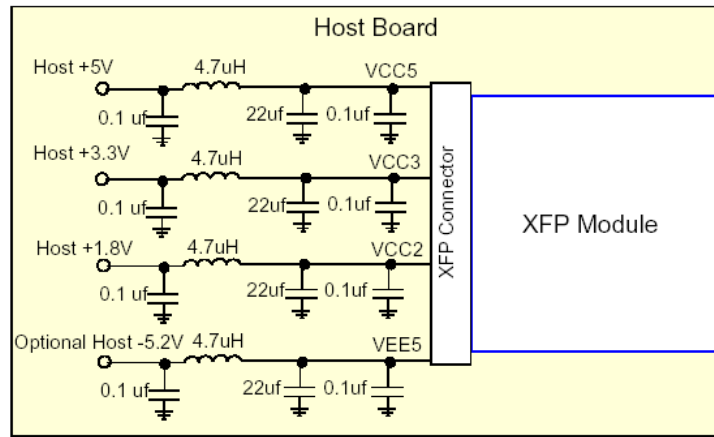

Figure 2, Recommended Host Board Power Supply Circuit

### Recommended Interface Circuit

Figure 3 shows the recommended interface circuit.

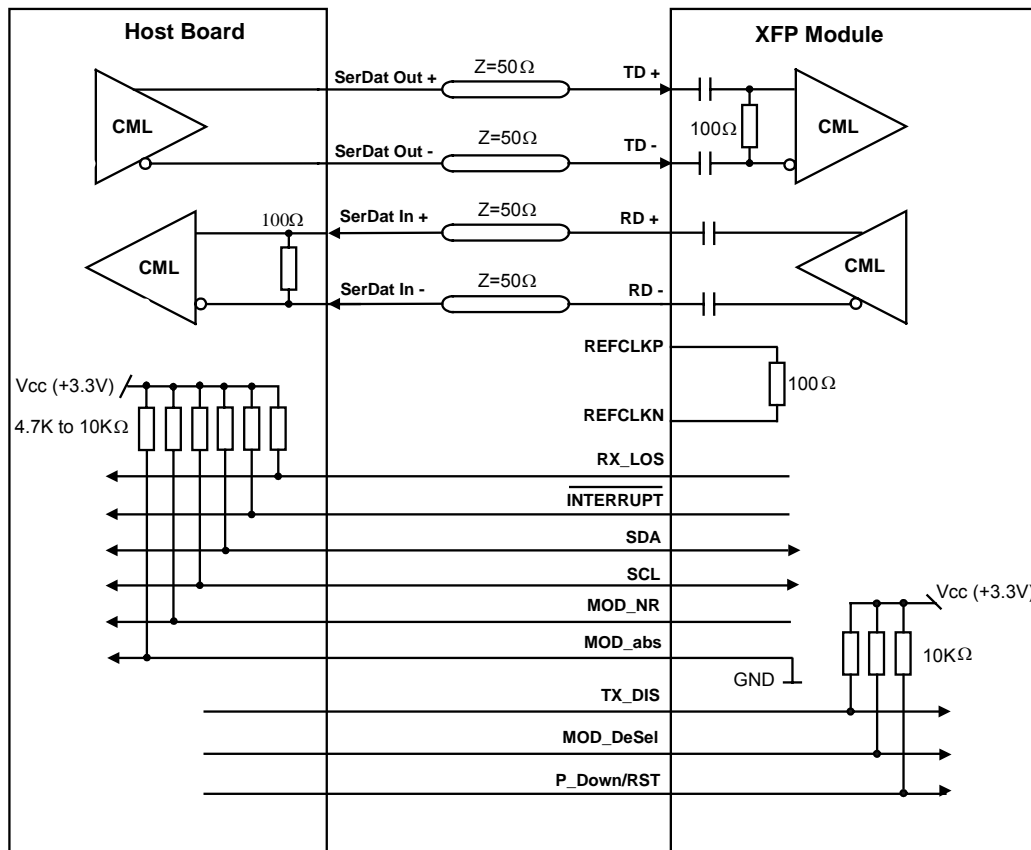

Figure 3, Recommended Interface Circuit

### Pin Definitions

Figure 4 below shows the pin numbering of XFP electrical interface. The pin functions are described in Table 5 with some accompanying notes.

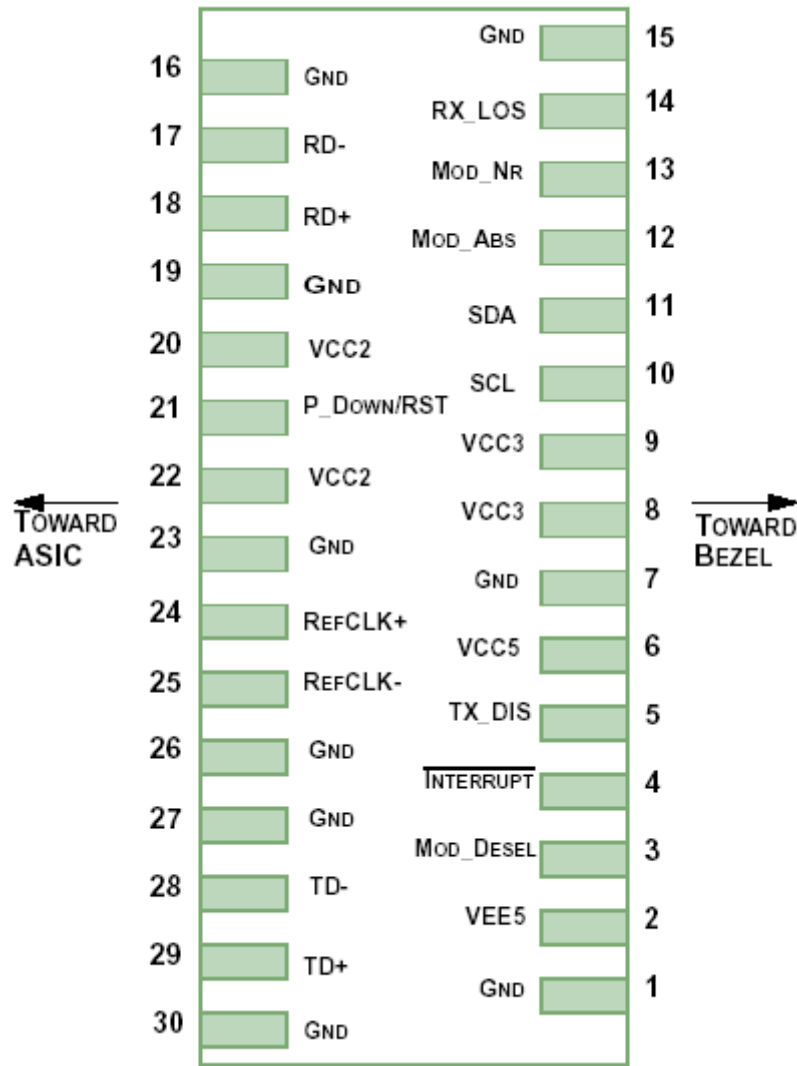

Figure 4, Pin View

Table 8 – Pin Function Definitions

Pin	Logic	Symbol	Name/Description	Note
1		GND	Module Ground	1
2		V <sub>EE5</sub>	Optional -5.2V Power Supply (Not implemented)	
3	LVTTL-I	Mod_DeSel	Module De-select; When held low allows the module to respond to 2-wire serial interface	
4	LVTTL-O	Interrupt	Interrupt; Indicates presence of an important condition which can be read over the 2-wire serial interface	2
5	LVTTL-I	TX_DIS	Transmitter Disable; Turns off transmitter laser output	
6		V <sub>CC5</sub>	+5V Power Supply	



7		GND	Module Ground	1
8		V <sub>CC3</sub>	+3.3V Power Supply	
9		V <sub>CC3</sub>	+3.3V Power Supply	
10	LVTTL-I/O	SCL	2-Wire Serial Interface Clock	2
11	LVTTL-I/O	SDA	2-Wire Serial Interface Data Line	2
12	LVTTL-O	Mod_Abs	Indicates Module is not present. Grounded in the Module	2
13	LVTTL-O	Mod_NR	Module Not Ready; Indicating Module Operational Fault	2
14	LVTTL-O	RX_LOS	Receiver Loss Of Signal Indicator	2
15		GND	Module Ground	1
16		GND	Module Ground	1
17	CML-O	RD-	Receiver Inverted Data Output	
18	CML-O	RD+	Receiver Non-Inverted Data Output	
19		GND	Module Ground	1
20		V <sub>CC2</sub>	+1.8V Power Supply (Not implemented).	3
21	LVTTL-I	P_Down/RST	Power down; When high, requires the module to limit power consumption to 1.5W or below. 2-Wire serial interface must be functional in the low power mode.	
			Reset; The falling edge initiates a complete reset of the module including the 2-wire serial interface, equivalent to a power cycle.	
22		V <sub>CC2</sub>	+1.8V Power Supply (Not implemented)	3
23		GND	Module Ground	1
24	PECL-I	RefCLK+	Not used, internally terminated to 50ohm (100ohm diff).	4
25	PECL-I	RefCLK-	Not used, internally terminated to 50ohm (100ohm diff).	4
26		GND	Module Ground	1
27		GND	Module Ground	1
28	CML-I	TD-	Transmitter Inverted Data Input	
29	CML-I	TD+	Transmitter Non-Inverted Data Input	
30		GND	Module Ground	1

1. Module ground pins GND are isolated from the module case and chassis ground within the module.
2. Shall be pulled up with 4.7K-10Kohms to a voltage between 3.15V and 3.45V on the host board.
3. The pins are open within module.
4. Reference Clock is not required.

**Mechanical Design Diagram**

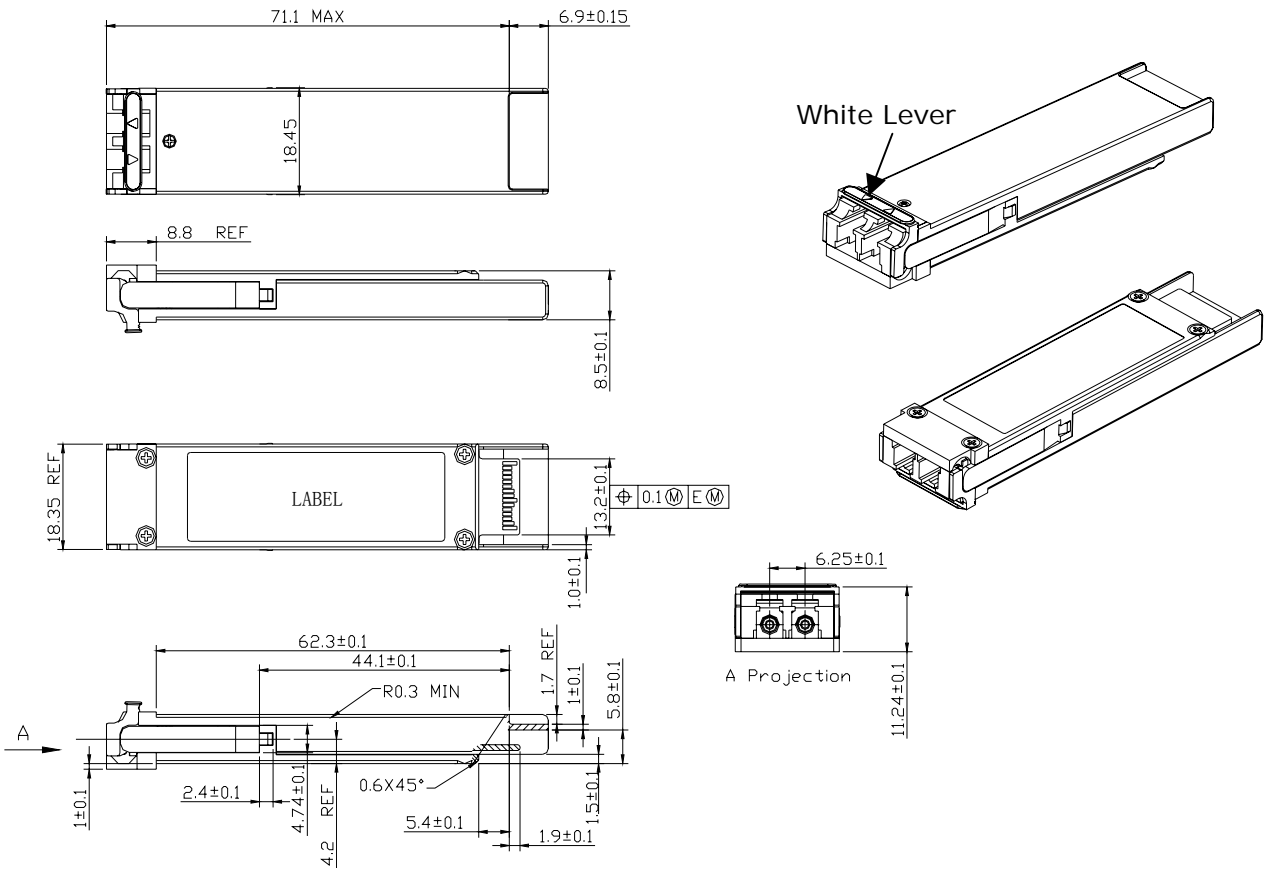

**Figure 5, Mechanical Design Diagram of XFP**

**Ordering information**

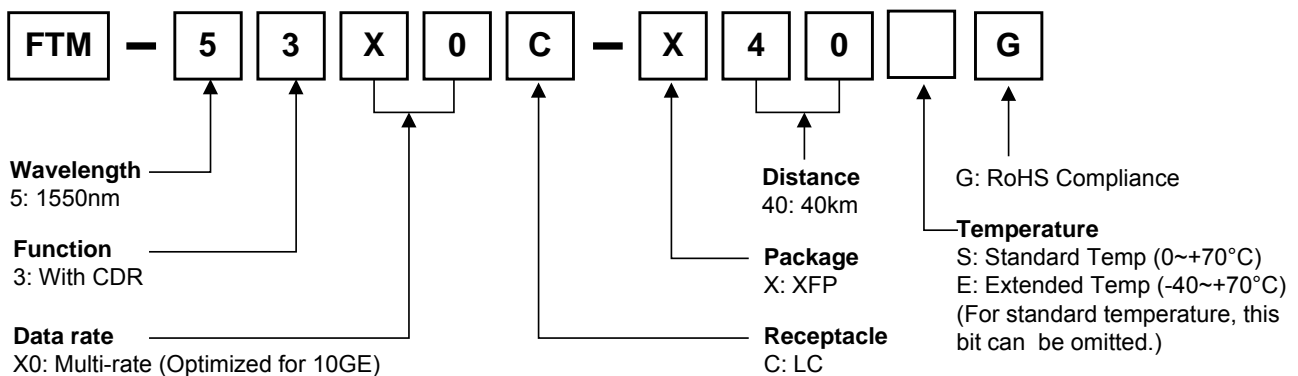

Part No.	Product Description
<b>FTM-53X0C-X40G</b>	1550nm EML Laser, multi-rate for 10GE, 40km, XFP, 0~+70°C, RoHS compliance
<b>FTM-53X0C-X40EG</b>	1550nm EML Laser, multi-rate for 10GE, 40km, XFP, -40~+70°C, RoHS compliance

## Related Documents

- *INF-8077i (10 Gigabit Small Form Factor Pluggable Module), Revision 4.0*

## Obtaining Document

You can visit our website:

<http://www.fiberxon.com>

Or contact with Fiberxon, Inc. America Sales Office listed at the end of documentation to get the latest documents.

## Revision History

Revision	Initiate	Review	Approve	Subject	Release Date
Rev. 1a	Andy.Xiao	Jashon.Wang	Alain.Shang	Initial datasheet	Mar. 28, 2006
Rev. 1b	Andy.Xiao	Jashon.Wang	Alain.Shang	Update the power supply current	Jun. 16, 2006

### © Copyright Fiberxon Inc. 2006

All Rights Reserved.

All information contained in this document is subject to change without notice. The products described in this document are NOT intended for use in implantation or other life support applications where malfunction may result in injury or death to persons.

The information contained in this document does not affect or change Fiberxon product specifications or warranties. Nothing in this document shall operate as an express or implied license or indemnity under the intellectual property rights of Fiberxon or third parties. All information contained in this document was obtained in specific environments, and is presented as an illustration. The results obtained in other operating environment may vary.

THE INFORMATION CONTAINED IN THIS DOCUMENT IS PROVIDED ON AN "AS IS" BASIS. In no event will Fiberxon be liable for damages arising directly from any use of the information contained in this document.

### Contact

U.S.A. Headquarter:

5201 Great America Parkway, Suite 340

Santa Clara, CA 95054

U. S. A.

Tel: 408-562-6288

Fax: 408-562-6289

Or visit our website: <http://www.fiberxon.com>