



CX24123 Demodulator and FEC Decoder

Low-power QPSK demodulator for worldwide satellite set-top box applications

Conexant's broadband communications portfolio includes a comprehensive suite of semiconductor solutions that enable the digital home and information network. The CX24123 is a DVB, DSS, and DCII compliant demodulator and Forward Error Correction (FEC) decoder. When combined with a satellite tuner, such as the CX24109 tuner, the CX24123 provides a complete broadband satellite front-end solution capable of operating from 1 to 45 Msps.

The CX24123 is the ideal solution for a wide variety of applications in digital satellite set-top box, personal computer receivers and residential gateways. This DiSEqC™ 2.x compliant demodulator enables two-way communication between the set-top box and peripheral satellite equipment such as Low-Noise Block Converters (LNB) and switches.

Providing digital derotation, digital filtering, equalization, and Viterbi/Reed-Solomon FEC, the CX24123 provides many advanced features that enhance overall system performance. The CX24123 automatically corrects for external quadrature gain/phase imbalances and for DC offsets. Input signal level variations (e.g., due to rain fade) are compensated by automatic gain control (AGC). Frequency offsets due to inexpensive consumer LNBs are corrected by a robust Carrier-Tracking Loop.

A unique feature of the CX24123 is an automatic acquisition algorithm that searches and acquires the carrier within a ± 10 MHz range during initial acquisition and performs a smart search to reacquire the carrier during fade conditions. The CX24123 has integrated signal-to-noise Ratio (SNR) and Bit Error Rate (BER) monitors for basic channel performance measurements, which saves time and test equipment during production.



CX24123 Distinguishing Features

- DVB/DSS/DCII - compliant
- Symbol rates: 1 to 45 Msps
- Automatic acquisition
- Low-power design
- Internal SNR and BER monitors
- DiSEqC™ Level 2.x compatible
- Low-Noise Block Converter (LNB) control
- Available in both 80 and 64 pin TQFP

Part Number CX24123

Description Demodulator and FEC Decoder



CX24123 Features

- DVB/DSS/DCII-compliant
- Symbol rates 1 to 45 Msps
- Internal PLL, only a single low-frequency crystal or clock is required
- Automatic acquisition
- ± 10 MHz acquisition range
- Carrier tracking: ± 5 MHz
- 6-bit Analog-to-Digital Converters (ADCs)
- 4-bit soft decision
- Digital matched filtering
- Multirate decimation filter
- Internal carrier and bit-timing recovery
- Boundary scan test function
- Serial or parallel output data interface
- External symbol clock reference
- Internal SNR and BER monitors
- DiSEqC™ level 2.x two-way Low-Noise Block Converter (LNB) control
- Power-down mode
- Quadrature equalization compensation
 - ± 3.0 dB gain imbalance
 - ± 13 -degree phase offset

CX24123 Applications

- DVB/DSS/DCII set-top box and PC receivers
- Residential gateways

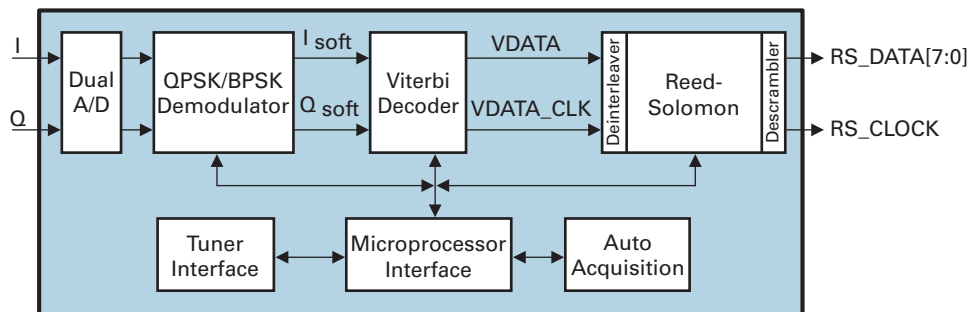

CX24123 Block Diagram

© 2003, Conexant Systems, Inc. All Rights Reserved. Conexant and the Conexant logo are trademarks of Conexant Systems, Inc. All other trademarks are owned by their respective owners. Although Conexant strives for accuracy in all its publications, this material may contain errors or omissions and is subject to change without notice. **THIS MATERIAL IS PROVIDED AS IS AND WITHOUT ANY EXPRESS OR IMPLIED WARRANTIES, INCLUDING MERCHANTABILITY, FITNESS FOR A PARTICULAR PURPOSE AND NON-INFRINGEMENT.** Conexant shall not be liable for any special, indirect, incidental or consequential damages as a result of its use.

www.conexant.com
 General Information:
 U.S. and Canada: (800) 854-8099
 International: (949) 483-6996
 Headquarters – Newport Beach
 4311 Jamboree Rd, P.O. Box C
 Newport Beach, CA 92660-3095
 Order# 102134A

