



Peak Reducing EMI Solution

Features

- Cypress PREMIS™ family offering
- Generates an EMI optimized clocking signal at the output
- Selectable input to output frequency
- Single 1.25% or 3.75% down or center spread output
- Integrated loop filter components
- Operates with a 3.3V or 5V supply
- Low power CMOS design
- Available in 8-pin SOIC (Small Outline Integrated Circuit) or 14-pin TSSOP (Thin Shrink Small Outline Package select options only)

Key Specifications

Supply Voltages: $V_{DD} = 3.3V \pm 5\%$
or $V_{DD} = 5V \pm 10\%$

Frequency Range: $28 \text{ MHz} \leq F_{in} \leq 75 \text{ MHz}$

Crystal Reference Range..... $28 \text{ MHz} \leq F_{in} \leq 40 \text{ MHz}$

Cycle to Cycle Jitter: 300 ps (max.)

Selectable Spread Percentage: 1.25% or 3.75%

Output Duty Cycle: 40/60% (worst case)

Output Rise and Fall Time: 5 ns (max.)

Table 1. Modulation Width Selection

| SS% | W181-01, 02, 03 Output | W181-51, 52, 53 Output |
|-----|--|---|
| 0 | $F_{in} \geq F_{out} \geq F_{in} - 1.25\%$ | $F_{in} + 0.625\% \geq F_{out} \geq F_{in} - 0.625\%$ |
| 1 | $F_{in} \geq F_{out} \geq F_{in} - 3.75\%$ | $F_{in} + 1.875\% \geq F_{out} \geq F_{in} - 1.875\%$ |

Table 2. Frequency Range Selection

| | | W181 Option# | | |
|-----|-----|--------------------------|--------------------------|--------------------------|
| FS2 | FS1 | -01, 51 (MHz) | -02, 52 (MHz) | -03, 53 (MHz) |
| 0 | 0 | $28 \leq F_{IN} \leq 38$ | $28 \leq F_{IN} \leq 38$ | N/A |
| 0 | 1 | $38 \leq F_{IN} \leq 48$ | $38 \leq F_{IN} \leq 48$ | N/A |
| 1 | 0 | $46 \leq F_{IN} \leq 60$ | N/A | $46 \leq F_{IN} \leq 60$ |
| 1 | 1 | $58 \leq F_{IN} \leq 75$ | N/A | $58 \leq F_{IN} \leq 75$ |

Simplified Block Diagram

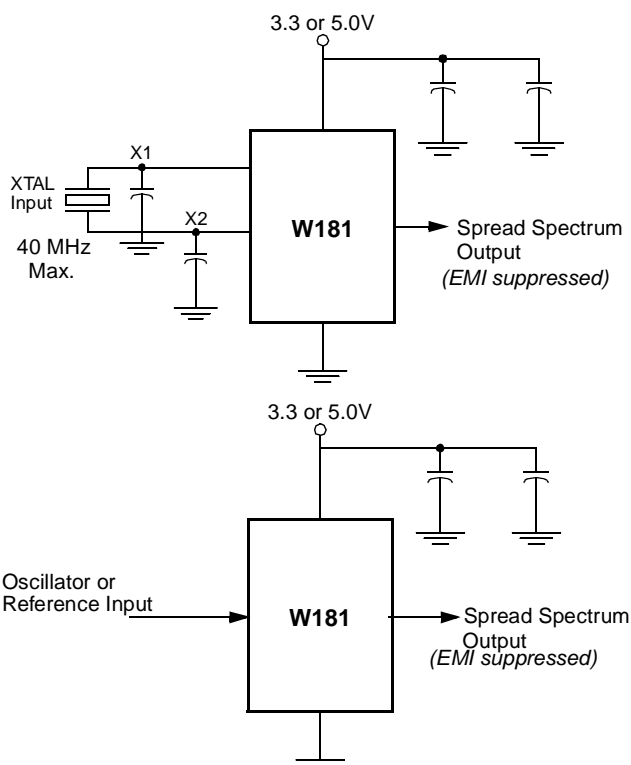

Pin Configurations

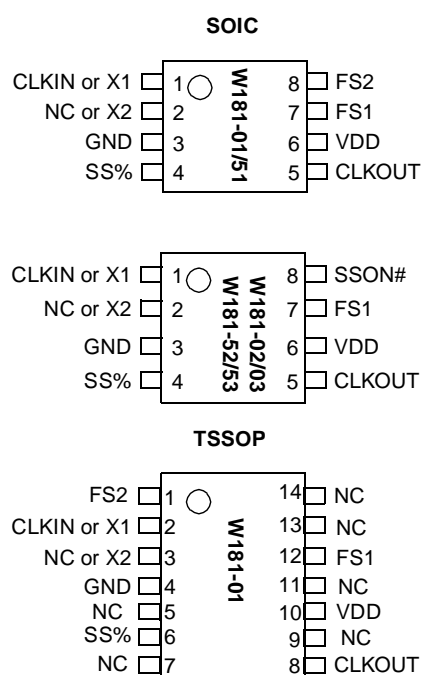

PREMIS is a trademark of Cypress Semiconductor Corporation.

Pin Definitions

| Pin Name | Pin No. (SOIC) | Pin No. (TSSOP)(-01) | Pin Type | Pin Description |
|-------------|----------------|----------------------|----------|--|
| CLKOUT | 5 | 8 | O | Output Modulated Frequency: Frequency modulated copy of the unmodulated input clock (SSON# asserted). |
| CLKIN or X1 | 1 | 2 | I | Crystal Connection or External Reference Frequency Input: This pin has dual functions. It may either be connected to an external crystal, or to an external reference clock. |
| NC or X2 | 2 | 3 | I | Crystal Connection: If using an external reference, this pin must be left unconnected. |
| SSON# | 8(02/03/52/53) | -- | I | Spread Spectrum Control (Active LOW): Asserting this signal (active LOW) turns the internal modulation waveform on. This pin has an internal pull-down resistor. |
| FS1:2 | 7, 8 (01/51) | 12, 1 | I | Frequency Selection Bit(s) 1 and 2: These pins select the frequency range of operation. Refer to <i>Table 2</i> . These pins have internal pull-up resistors. |
| SS% | 4 | 6 | I | Modulation Width Selection: When Spread Spectrum feature is turned on, this pin is used to select the amount of variation and peak EMI reduction that is desired on the output signal. This pin has an internal pull-up resistor. |
| VDD | 6 | 10 | P | Power Connection: Connected to 3.3V or 5V power supply. |
| GND | 3 | 4 | G | Ground Connection: Connect all ground pins to the common system ground plane. |
| NC | | 5, 7, 9, 11, 13, 14 | NC | No Connection. |

Overview

The W181 products are one series of devices in the Cypress PREMIS family. The PREMIS family incorporates the latest advances in PLL spread spectrum frequency synthesizer techniques. By frequency modulating the output with a low-frequency carrier, peak EMI is greatly reduced. Use of this technology allows systems to pass increasingly difficult EMI testing without resorting to costly shielding or redesign.

In a system, not only is EMI reduced in the various clock lines, but also in all signals which are synchronized to the clock. Therefore, the benefits of using this technology increase with the number of address and data lines in the system. The Simplified Block Diagram on page 1 shows a simple implementation.

Functional Description

The W181 uses a Phase-Locked Loop (PLL) to frequency modulate an input clock. The result is an output clock whose frequency is slowly swept over a narrow band near the input signal. The basic circuit topology is shown in *Figure 1*. The input reference signal is divided by Q and fed to the phase detector. A signal from the VCO is divided by P and fed back to the phase detector also. The PLL will force the frequency of the VCO output signal to change until the divided output signal and the divided reference signal match at the phase detector input. The output frequency is then equal to the ratio of P/Q

times the reference frequency. (Note: For the W181 the output frequency is equal to the input frequency.) The unique feature of the Spread Spectrum Frequency Timing Generator is that a modulating waveform is superimposed at the input to the VCO. This causes the VCO output to be slowly swept across a pre-determined frequency band.

Because the modulating frequency is typically 1000 times slower than the fundamental clock, the spread spectrum process has little impact on system performance.

Frequency Selection With SSFTG

In Spread Spectrum Frequency Timing Generation, EMI reduction depends on the shape, modulation percentage, and frequency of the modulating waveform. While the shape and frequency of the modulating waveform are fixed for a given frequency, the modulation percentage may be varied.

Using frequency select bits (FS1:2 pins), the frequency range can be set. Spreading percentage is set to be 1.25% or 3.75% (see *Table 1*).

A larger spreading percentage improves EMI reduction. However, large spread percentages may either exceed system maximum frequency ratings or lower the average frequency to a point where performance is affected. For these reasons, spreading percentages between 0.5% and 2.5% are most common.

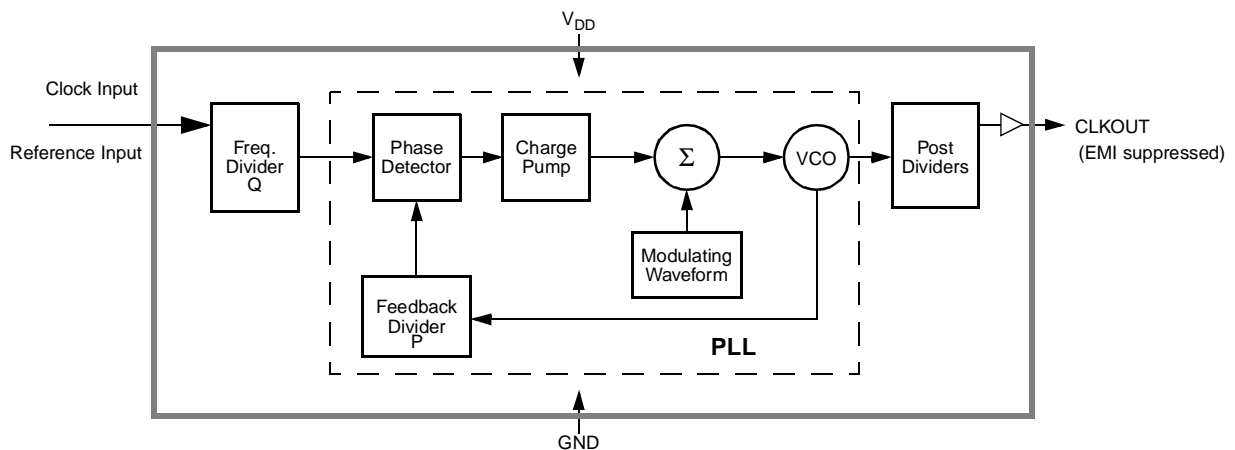

Figure 1. Functional Block Diagram

Spread Spectrum Frequency Timing Generation

The device generates a clock that is frequency modulated in order to increase the bandwidth that it occupies. By increasing the bandwidth of the fundamental and its harmonics, the amplitudes of the radiated electromagnetic emissions are reduced. This effect is depicted in *Figure 2*.

As shown in *Figure 2*, a harmonic of a modulated clock has a much lower amplitude than that of an unmodulated signal. The reduction in amplitude is dependent on the harmonic number and the frequency deviation or spread. The equation for the reduction is:

$$dB = 6.5 + 9 \cdot \log_{10}(P) + 9 \cdot \log_{10}(F)$$

Where *P* is the percentage of deviation and *F* is the frequency in MHz where the reduction is measured.

The output clock is modulated with a waveform depicted in *Figure 3*. This waveform, as discussed in “Spread Spectrum Clock Generation for the Reduction of Radiated Emissions” by Bush, Fessler, and Hardin produces the maximum reduction in the amplitude of radiated electromagnetic emissions. *Figure 3* details the Cypress spreading pattern. Cypress does offer options with more spread and greater EMI reduction. Contact your local Sales representative for details on these devices.

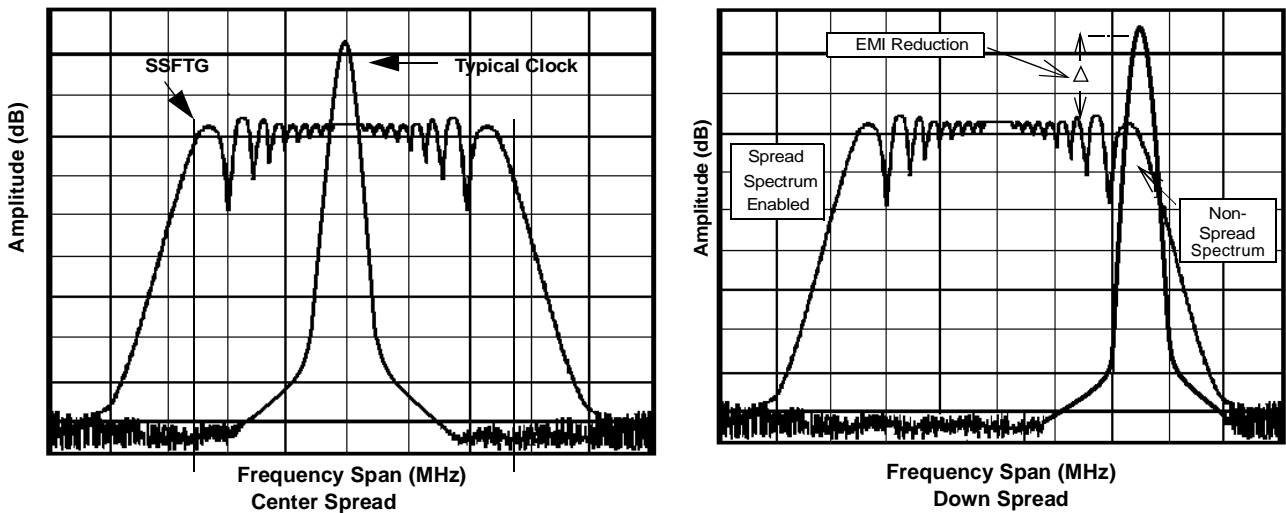

Figure 2. Clock Harmonic with and without SSCG Modulation Frequency Domain Representation

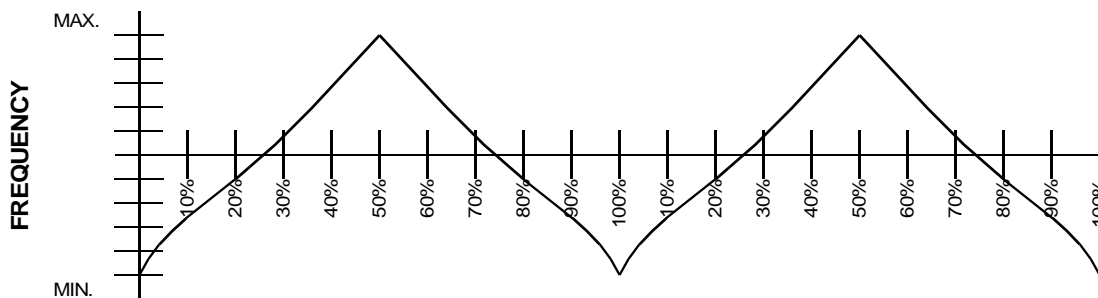

Figure 3. Typical Modulation Profile

Absolute Maximum Ratings

Stresses greater than those listed in this table may cause permanent damage to the device. These represent a stress rating only. Operation of the device at these or any other conditions

above those specified in the operating sections of this specification is not implied. Maximum conditions for extended periods may affect reliability.

| Parameter | Description | Rating | Unit |
|------------------|--|--------------|------|
| V_{DD}, V_{IN} | Voltage on any pin with respect to GND | -0.5 to +7.0 | V |
| T_{STG} | Storage Temperature | -65 to +150 | °C |
| T_A | Operating Temperature | 0 to +70 | °C |
| T_B | Ambient Temperature under Bias | -55 to +125 | °C |
| P_D | Power Dissipation | 0.5 | W |

DC Electrical Characteristics: $0^{\circ}\text{C} < T_A < 70^{\circ}\text{C}$, $V_{DD} = 3.3\text{V} \pm 5\%$

| Parameter | Description | Test Condition | Min. | Typ. | Max. | Unit |
|-----------|------------------------|---|------|------|------|------|
| I_{DD} | Supply Current | | | 18 | 32 | mA |
| t_{ON} | Power-Up Time | First locked clock cycle after Power Good | | | 5 | ms |
| V_{IL} | Input Low Voltage | | | | 0.8 | V |
| V_{IH} | Input High Voltage | | 2.4 | | | V |
| V_{OL} | Output Low Voltage | | | | 0.4 | V |
| V_{OH} | Output High Voltage | | 2.4 | | | V |
| I_{IL} | Input Low Current | Note 1 | | | -100 | μA |
| I_{IH} | Input High Current | Note 1 | | | 10 | μA |
| I_{OL} | Output Low Current | @ 0.4V, $V_{DD} = 3.3\text{V}$ | | 15 | | mA |
| I_{OH} | Output High Current | @ 2.4V, $V_{DD} = 3.3\text{V}$ | | 15 | | mA |
| C_I | Input Capacitance | All pins except CLKIN | | | 7 | pF |
| C_I | Input Capacitance | CLKIN pin only | | 6 | 10 | pF |
| R_P | Input Pull-Up Resistor | | | 500 | | kΩ |
| Z_{OUT} | Clock Output Impedance | | | 25 | | Ω |

Note:

- Inputs FS1:2 have a pull-up resistor; Input SSON# has a pull-down resistor.

DC Electrical Characteristics: $0^{\circ}\text{C} < T_A < 70^{\circ}\text{C}$, $V_{DD} = 5\text{V} \pm 10\%$

| Parameter | Description | Test Condition | Min. | Typ. | Max. | Unit |
|-----------|------------------------|---|-------------|------|--------------|---------------|
| I_{DD} | Supply Current | | | 30 | 50 | mA |
| t_{ON} | Power-Up Time | First locked clock cycle after Power Good | | | 5 | ms |
| V_{IL} | Input Low Voltage | | | | $0.15V_{DD}$ | V |
| V_{IH} | Input High Voltage | | $0.7V_{DD}$ | | | V |
| V_{OL} | Output Low Voltage | | | | 0.4 | V |
| V_{OH} | Output High Voltage | | 2.4 | | | V |
| I_{IL} | Input Low Current | Note 1 | | | -100 | μA |
| I_{IH} | Input High Current | Note 1 | | | 10 | μA |
| I_{OL} | Output Low Current | @ 0.4V, $V_{DD} = 5\text{V}$ | | 24 | | mA |
| I_{OH} | Output High Current | @ 2.4V, $V_{DD} = 5\text{V}$ | | 24 | | mA |
| C_I | Input Capacitance | All pins except CLKIN | | | 7 | pF |
| C_I | Input Capacitance | CLKIN pin only | | 6 | 10 | pF |
| R_P | Input Pull-Up Resistor | | | 500 | | k Ω |
| Z_{OUT} | Clock Output Impedance | | | 25 | | Ω |

AC Electrical Characteristics: $T_A = 0^{\circ}\text{C}$ to $+70^{\circ}\text{C}$, $V_{DD} = 3.3\text{V} \pm 5\%$ or $5\text{V} \pm 10\%$

| Parameter | Description | Test Condition | Min. | Typ. | Max. | Unit |
|------------|------------------------|---|------|------|------|------|
| f_{IN} | Input Frequency | Input Clock | 28 | | 75 | MHz |
| f_{OUT} | Output Frequency | Spread Off | 28 | | 75 | MHz |
| t_R | Output Rise Time | V_{DD} , 15-pF load 0.8V–2.4V | | 2 | 5 | ns |
| t_F | Output Fall Time | V_{DD} , 15-pF load 2.4V–0.8V | | 2 | 5 | ns |
| t_{OD} | Output Duty Cycle | 15-pF load | 40 | | 60 | % |
| t_{ID} | Input Duty Cycle | | 40 | | 60 | % |
| t_{JCYC} | Jitter, Cycle-to-Cycle | | | 250 | 300 | ps |
| | Harmonic Reduction | $f_{out} = 40\text{MHz}$, third harmonic measured, reference board, 15-pF load | 8 | | | dB |

Application Information

Recommended Circuit Configuration

For optimum performance in system applications the power supply decoupling scheme shown in *Figure 4* should be used.

V_{DD} decoupling is important to both reduce phase jitter and EMI radiation. The 0.1- μF decoupling capacitor should be placed as close to the V_{DD} pin as possible, otherwise the in-

creased trace inductance will negate its decoupling capability. The 10- μF decoupling capacitor shown should be a tantalum type. For further EMI protection, the V_{DD} connection can be made via a ferrite bead, as shown.

Recommended Board Layout

Figure 5 shows a recommended 2-layer board layout.

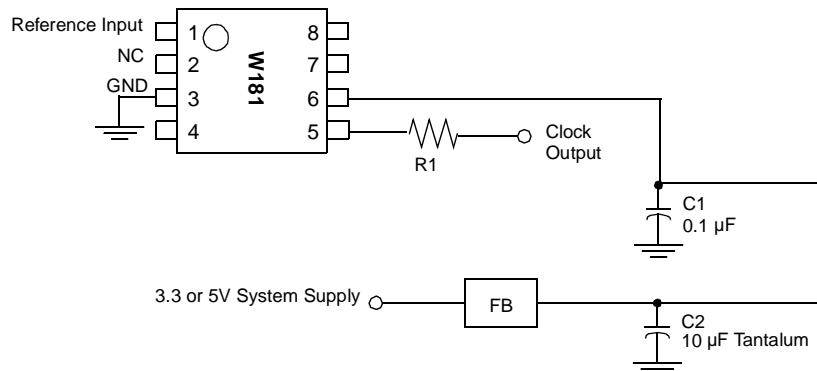

Figure 4. Recommended Circuit Configuration

- C1 = High frequency supply decoupling capacitor (0.1- μF recommended).
- C2 = Common supply low frequency decoupling capacitor (10- μF tantalum recommended).

R1 = Match value to line impedance

FB = Ferrite Bead

(G) = Via To GND Plane

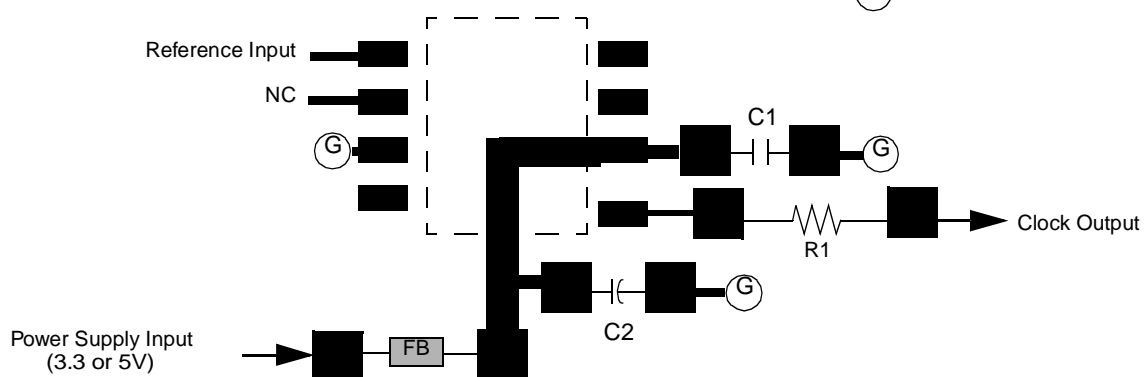

Figure 5. Recommended Board Layout (2-Layer Board)

Ordering Information

| Ordering Code | Freq. Mask Code | Package Name | Package Type |
|---------------|--------------------------|--------------|------------------------------|
| W181 | 01, 02, 03 51, 52, 53 | G | 8-pin Plastic SOIC (150-mil) |
| W181 | 01 | X | 14-pin Plastic TSSOP |

Package Diagram

14-pin Thin Shrink Small Outline Package

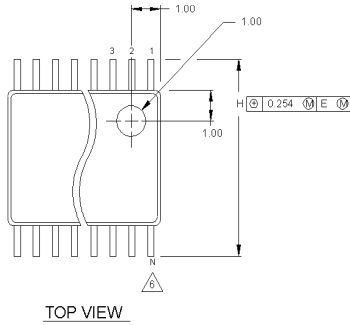

TOP VIEW

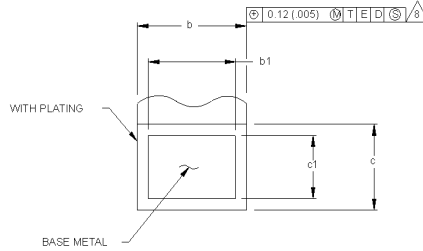

DETAIL "C"

SCALE: 120/1

(SEE NOTE 9)

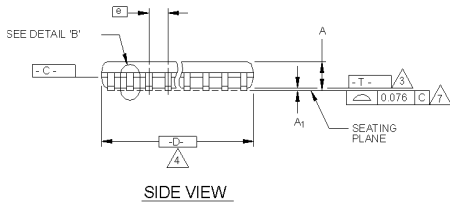

SIDE VIEW

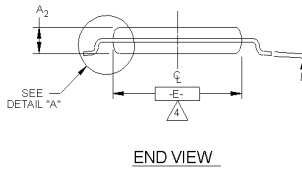

END VIEW

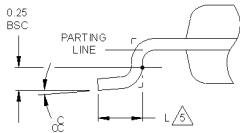

DETAIL "A"

(SCALE: 30/1)

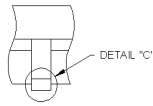

DETAIL "B"

(SCALE: 30/1)
DAMBAR PROTRUSION

NOTES:

1. DIE THICKNESS ALLOWABLE IS 0.279±0.0127 (0.110±0.005 INCHES)
2. DIMENSIONING & TOLERANCES PER ANSI Y14.5M-1982
- △ "T" IS A REFERENCE DATUM.
- △ "D" & "E" ARE REFERENCE DATUMS AND DO NOT INCLUDE MOLD FLASH OR PROTRUSIONS, AND ARE MEASURED AT THE PARTING LINE. MOLD FLASH OR PROTRUSIONS SHALL NOT EXCEED 0.15mm PER SIDE. DIMENSION IS THE LENGTH OF TERMINAL FOR SOLDERING TO A SUBSTRATE.
- △ TERMINAL POSITIONS ARE SHOWN FOR REFERENCE ONLY.
- △ FORMED LEADS SHALL BE PLANAR WITH RESPECT TO ONE ANOTHER WITHIN 0.076mm AT SEATING PLANE.
- △ THE LEAD WIDTH DIMENSION DOES NOT INCLUDE DAMBAR PROTRUSION. ALLOWABLE DAMBAR PROTRUSION SHALL BE 0.08mm TOTAL IN EXCESS OF THE LEAD WIDTH DIMENSION AT MAXIMUM MATERIAL CONDITION. DAMBAR CANNOT BE LOCATED ON THE LOWER RADIUS OR THE FOOT. MINIMUM SPACE BETWEEN PROTRUSIONS AND AN ADJACENT LEAD TO BE 0.14mm SEE DETAILS 'B' AND 'C'.
- △ DETAIL "C" TO BE DETERMINED AT 0.10 TO 0.25 MM FROM THE LEAD TIP.
10. CONTROLLING DIMENSION, MILLIMETERS.
11. THIS PART IS COMPLIANT WITH JEDEC SPECIFICATION MO-153. VARIATIONS AA, AB, AC, AD AND AE.

THIS TABLE IN MILLIMETERS

| SYMBOL | COMMON DIMENSIONS | | | NOTE VARIATIONS | 4 D | | | 6 N | |
|----------------|-------------------|-------|-------|-----------------|------|------|------|------|----|
| | MIN. | NOM. | MAX. | | MIN. | NOM. | MAX. | | |
| A | | | 1.10 | | AA | 2.90 | 3.00 | 3.10 | 8 |
| A ₁ | 0.05 | 0.10 | 0.15 | | AB | 4.90 | 5.00 | 5.10 | 14 |
| A ₂ | 0.85 | 0.90 | 0.95 | | AC | 4.90 | 5.00 | 5.10 | 16 |
| b | 0.19 | - | 0.30 | 8 | AD | 6.40 | 6.50 | 6.60 | 20 |
| b1 | 0.19 | 0.22 | 0.25 | | AE | 7.70 | 7.80 | 7.90 | 24 |
| c | 0.090 | - | 0.20 | | AF | 9.60 | 9.70 | 9.80 | 28 |
| c1 | 0.090 | 0.127 | 0.135 | | | | | | |
| D | SEE VARIATIONS | | | 4 | | | | | |
| E | 4.30 | 4.40 | 4.50 | 4 | | | | | |
| e | 0.65 BSC | | | | | | | | |
| H | 6.25 | 6.40 | 6.50 | | | | | | |
| L | 0.50 | 0.60 | 0.70 | 5 | | | | | |
| N | SEE VARIATIONS | | | 6 | | | | | |
| α | 0° | 4° | 8° | | | | | | |

THIS TABLE IN INCHES

| SYMBOL | COMMON DIMENSIONS | | | NOTE VARIATIONS | 4 D | | | 6 N | |
|----------------|-------------------|-------|-------|-----------------|------|------|------|------|----|
| | MIN. | NOM. | MAX. | | MIN. | NOM. | MAX. | | |
| A | | | .0433 | | AA | .114 | .118 | .122 | 8 |
| A ₁ | .002 | .004 | .006 | | AB | .193 | .197 | .201 | 14 |
| A ₂ | .0335 | .0354 | .0374 | | AC | .193 | .197 | .201 | 16 |
| b | .0075 | - | .0118 | 8 | AD | .252 | .256 | .260 | 20 |
| b1 | .0075 | .0087 | .0098 | | AE | .303 | .307 | .311 | 24 |
| c | .0035 | - | .0079 | | AF | .378 | .382 | .386 | 28 |
| c1 | .0035 | .0050 | .0053 | | | | | | |
| D | SEE VARIATIONS | | | 4 | | | | | |
| E | .169 | .173 | .177 | 4 | | | | | |
| e | .0256 BSC | | | | | | | | |
| H | .246 | .252 | .256 | | | | | | |
| L | .020 | .024 | .028 | 5 | | | | | |
| N | SEE VARIATIONS | | | 6 | | | | | |
| α | 0° | 4° | 8° | | | | | | |

VARIATION AF IS DESIGNED BUT NOT TOOLED

Package Diagram (continued)

8-Pin Small Outline Integrated Circuit (SOIC, 150 mils)

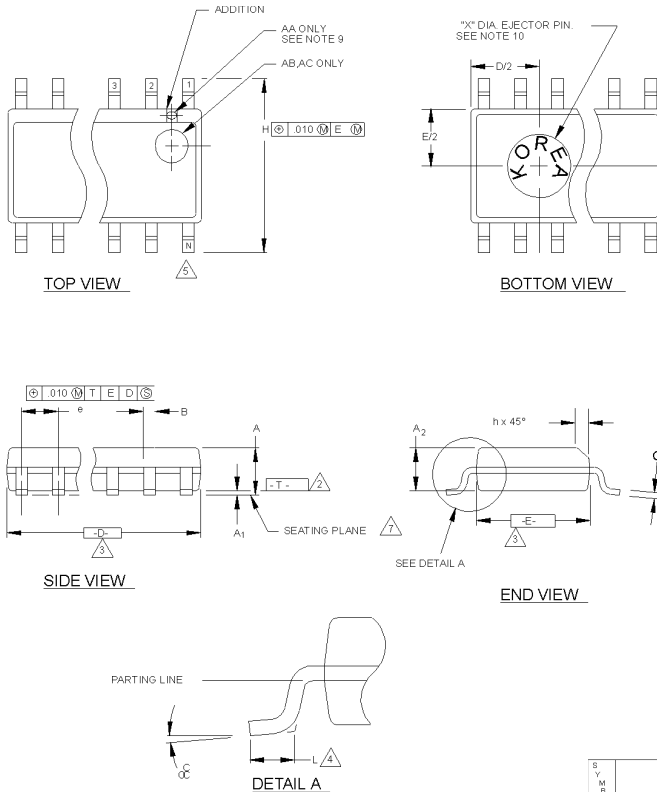

THIS TABLE IN INCHES

| SYMBOL | COMMON DIMENSIONS | | | NOTE VARIATIONS | 3 | | | 5 |
|----------------|-------------------|------|-------|-----------------|------|------|------|----|
| | MIN. | NOM. | MAX. | | D | | | |
| A | .061 | .064 | .068 | AA | .189 | .194 | .196 | 8 |
| A ₁ | .004 | .006 | .0098 | AB | .337 | .342 | .344 | 14 |
| A ₂ | .055 | .058 | .061 | AC | .386 | .391 | .393 | 16 |
| B | .0138 | .016 | .0192 | | | | | |
| C | .0075 | .008 | .0098 | | | | | |
| D | SEE VARIATIONS | | | 3 | | | | |
| E | .150 | .155 | .157 | | | | | |
| e | .050 BSC | | | | | | | |
| H | .230 | .236 | .244 | | | | | |
| h | .010 | .013 | .016 | | | | | |
| L | .016 | .025 | .035 | | | | | |
| N | SEE VARIATIONS | | | 5 | | | | |
| d | 0° | 5° | 8° | | | | | |
| X | .085 | .093 | .100 | | | | | |

THIS TABLE IN MILLIMETERS

| SYMBOL | COMMON DIMENSIONS | | | NOTE VARIATIONS | 3 | | | 5 |
|----------------|-------------------|------|------|-----------------|------|------|------|----|
| | MIN. | NOM. | MAX. | | D | | | |
| A | 1.55 | 1.63 | 1.73 | AA | 4.80 | 4.93 | 4.98 | 8 |
| A ₁ | 0.127 | 0.15 | 0.25 | AB | 8.58 | 8.69 | 8.74 | 14 |
| A ₂ | 1.40 | 1.47 | 1.55 | AC | 9.80 | 9.93 | 9.98 | 16 |
| B | 0.35 | 0.41 | 0.49 | | | | | |
| C | 0.19 | 0.20 | 0.25 | | | | | |
| D | SEE VARIATIONS | | | 3 | | | | |
| E | 3.81 | 3.94 | 3.99 | | | | | |
| e | 1.27 BSC | | | | | | | |
| H | 5.84 | 5.99 | 6.20 | | | | | |
| h | 0.25 | 0.33 | 0.41 | | | | | |
| L | 0.41 | 0.64 | 0.89 | | | | | |
| N | SEE VARIATIONS | | | 5 | | | | |
| d | 0° | 5° | 8° | | | | | |
| X | 2.16 | 2.36 | 2.54 | | | | | |