

## Adjustable Shunt Regulator

### OUTLINE

The BL431 is three-terminal adjustable shunt regulators with guaranteed thermal stability over a full operation range.

The output voltage may be set to any value between  $V_{ref}$  (approximately 2.5v) and 18v.

The BL431 precision reference is offered in bandgap tolerance: 0.4%.

The 4 main packages have low thermal impedance which allows operation over a wide range of  $-40$  to  $125^{\circ}\text{C}$ .

### FEATURES

- Programmable precise output voltage from 2.5v to 18v
- Low temperature deviation: 4.5mV typical
- Low equivalent full-range temperature coefficient with 30PPM/ $^{\circ}\text{C}$  typical
- Low dynamic output resistance:  $0.2\Omega$  typical
- Sink current capacity from 1mA to 100 mA
- Available in 4 packages: TO-92, SOT-23-3, SOT-89 and SOIC-8

### APPLICATIONS

- Charger
- Voltage Adapter
- Switching Power Supply
- Precision Voltage Reference

### Pin Configuration

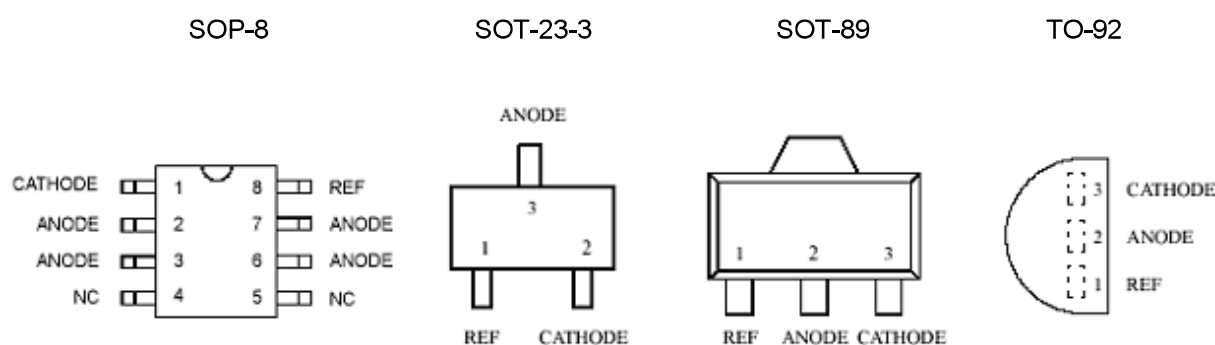
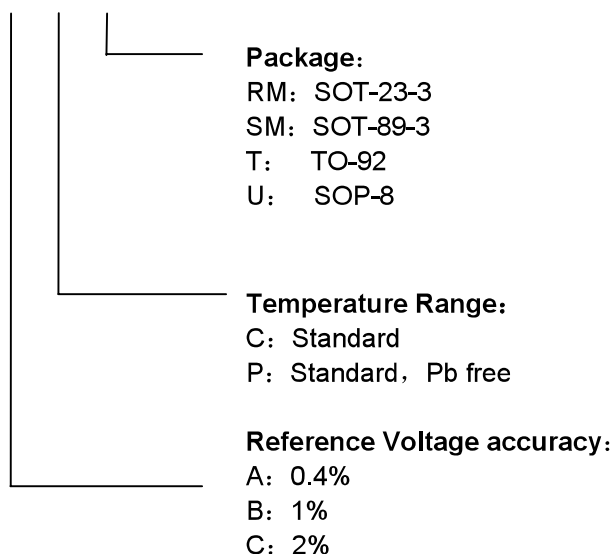

Figure 1. Pin Configuration of BL431

## Selection Guide: BL431-X X XX



## Functional Block Diagram

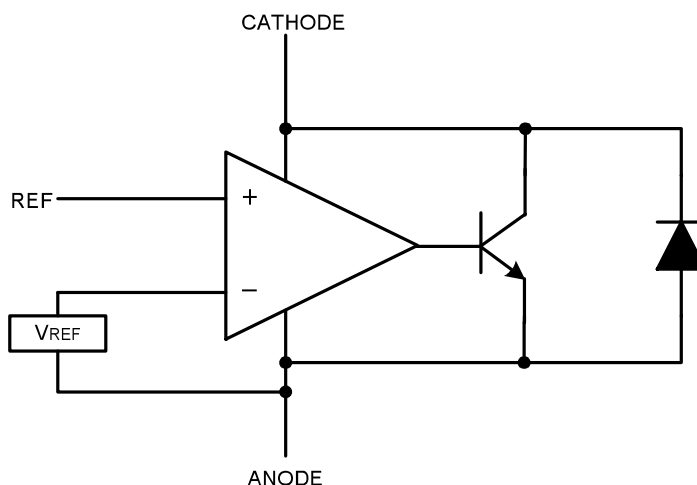

Figure 2. Functional Block Diagram of BL431

## Absolute Maximum Ratings

Parameter	Symbol	Ratings	Unit
Junction Temperature	$T_j$	150	$^{\circ}\text{C}$
Storage Temperature	$T_{stg}$	-65~+150	$^{\circ}\text{C}$
Cathode Voltage	$V_{KA}$	20	V
Cathode Current Range(Continuous)	$I_{KA}$	-100~+150	mA
Reference Input Current Range	$I_{REF}$	-0.05~+10	mA

Note: Stresses greater than those listed under "Absolute Maximum Ratings" may cause permanent damage to the device. These are stress ratings only, and functional operation of the device at these or any other conditions beyond those indicated under "Recommended Operation Ratings" is not implied. Exposure to "Absolute Maximum Ratings" for extended periods may affect device reliability.

**Recommended Operation Ratings**

Parameter	Symbol	Min.	Max.	Unit
Cathode Voltage	$V_{KA}$	$V_{REF}$	18	V
Cathode Current	$I_{KA}$	1.0	100	mA
Operating Ambient Temperature Range		-40	125	°C

**Electrical Characteristics**

 Operating Conditions:  $T_A = 25^\circ\text{C}$  unless otherwise specified.

Parameter	Test Circuit	Symbol	Conditions	BL431			Unit	
				Min.	Typ.	Max.		
Reference Voltage	3	$V_{REF}$	$V_{KA} = V_{REF}, I_{KA} = 10\text{mA}$	2.490 2.475 2.450	2.500 2.500 2.500	2.510 2.525 2.550	V	
Deviation of reference input Voltage Over temperature	3	$\Delta V_{REF}$	$V_{KA} = V_{REF}, I_{KA} = 10\text{mA}$	0 to 70°C	-	4.5	8	mV
				-40 to 85°C	-	4.5	15	
Ratio of change in reference input Voltage to the change in Cathode Voltage	4	$\Delta V_{REF}$ $\Delta V_{KA}$	$I_{KA} = 10\text{mA}$	$\Delta V_{KA} = 10\text{V}$ to $V_{REF}$	-	-1.0	-2.7	mV/V
				$\Delta V_{KA} = 18\text{V}$ to 10V	-	-0.5	-2.0	
Minimum Cathode Current for Regulation	3	$I_{KA}(\text{min})$	$V_{KA} = V_{REF}$	-	0.4	1.0	mA	
Dynamic Impedance	3	$Z_{KA}$	$V_{KA} = V_{REF}, I_{KA} = 1$ to 100mA, $f \leq 1.0\text{KHz}$	-	0.15	0.5	$\Omega$	
Reference Current	4	$I_{REF}$	$I_{KA} = 10\text{mA}, R1 = 10\text{K}\Omega, R2 = \infty$	-	1.5	4	$\mu\text{A}$	
Deviation of Reference Current Over Full Temperature Range	4	$\Delta I_{REF}$	$I_{KA} = 10\text{mA}, R1 = 10\text{K}\Omega, R2 = \infty, T_A = -40$ to 85°C	-	0.4	1.2	$\mu\text{A}$	
Off-State Cathode Current	5	$I_{KA}(\text{off})$	$V_{KA} = 18\text{V}, V_{REF} = 0$		0.05	1.0	$\mu\text{A}$	

**Test Circuit**

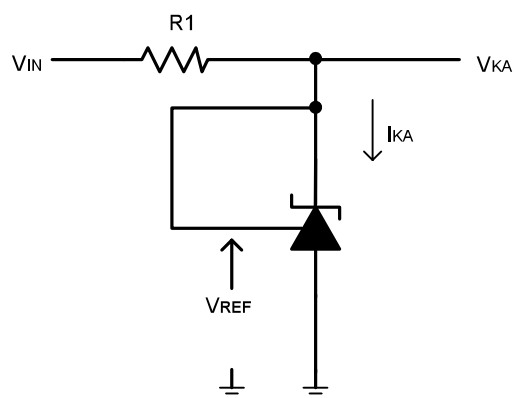

Figure 3. Test Circuit 3 for  $V_{KA} = V_{REF}$

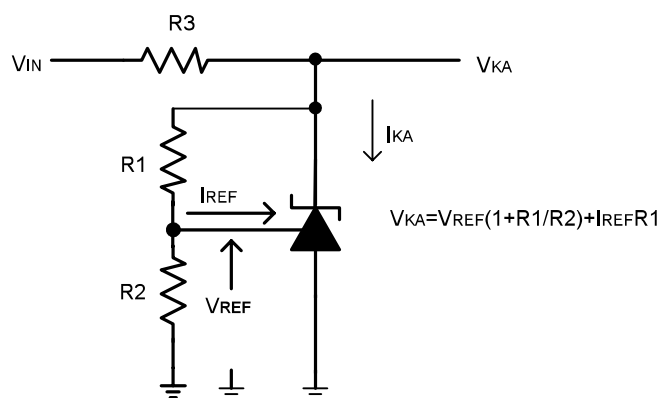

Figure 4. Test Circuit 4 for  $V_{KA} > V_{REF}$

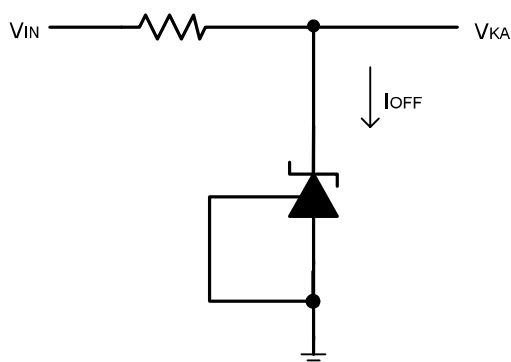

Figure 5. Test Circuit 5 for  $I_{off}$

**Typical Characteristics**

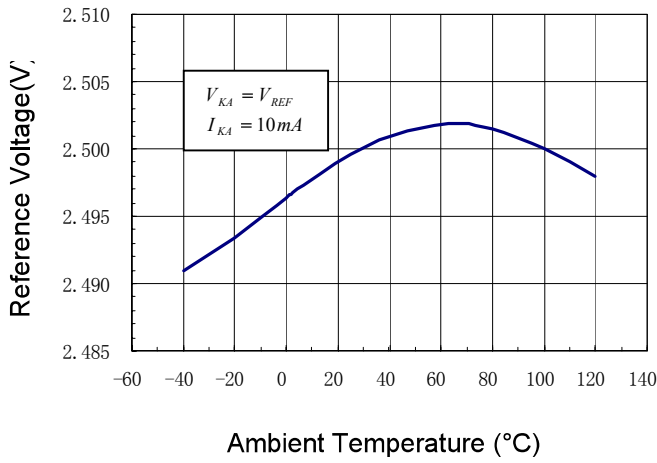

Figure 6. Reference Voltage vs. Ambient Temperature

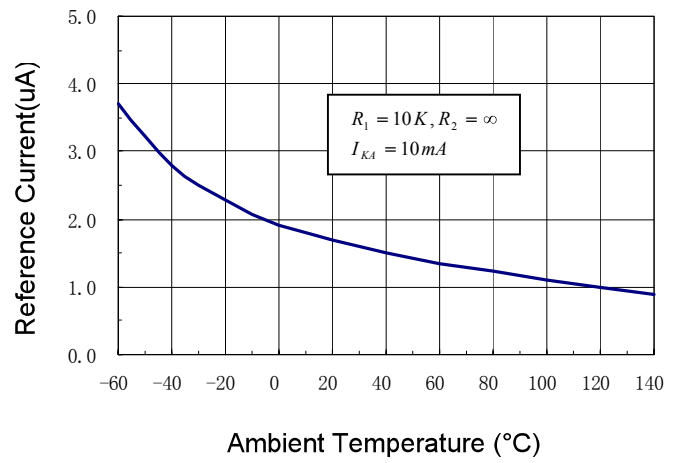

Figure 7. Reference Current vs. Ambient Temperature

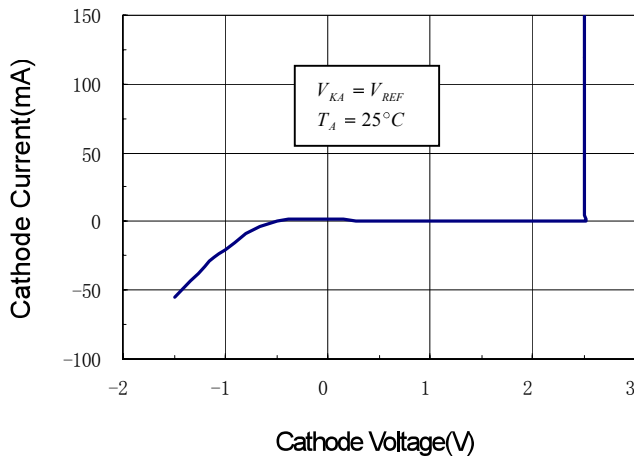

Figure 8. Cathode Current vs. Cathode Voltage

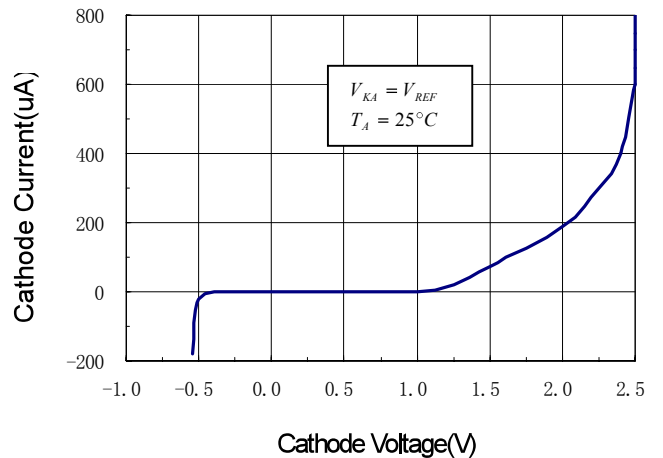

Figure 9. Current vs. Cathode Voltage

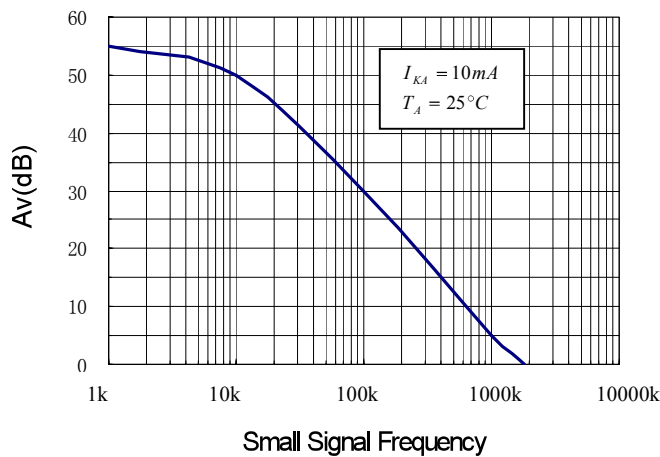
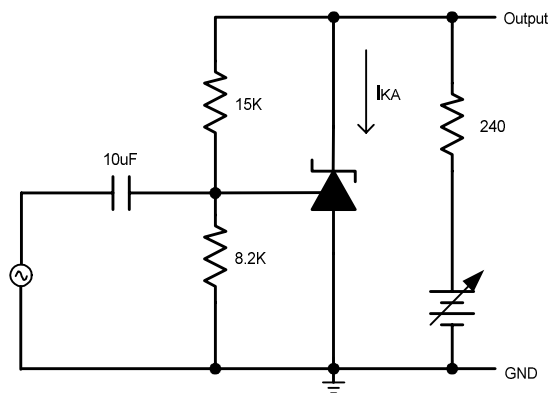

Figure 10. Small Signal Voltage Gain vs. Frequency



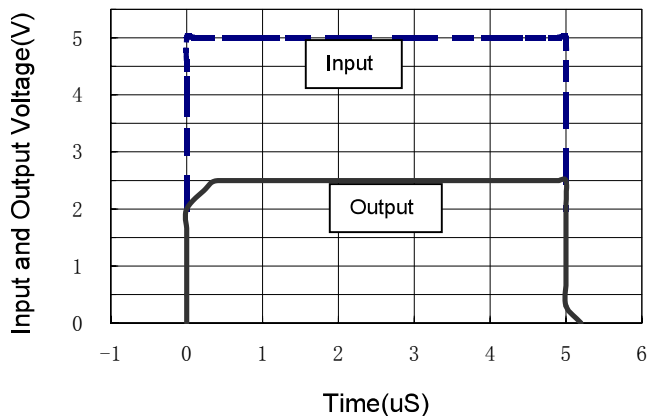

Figure 11. Pulse Response of Input and Output Voltage

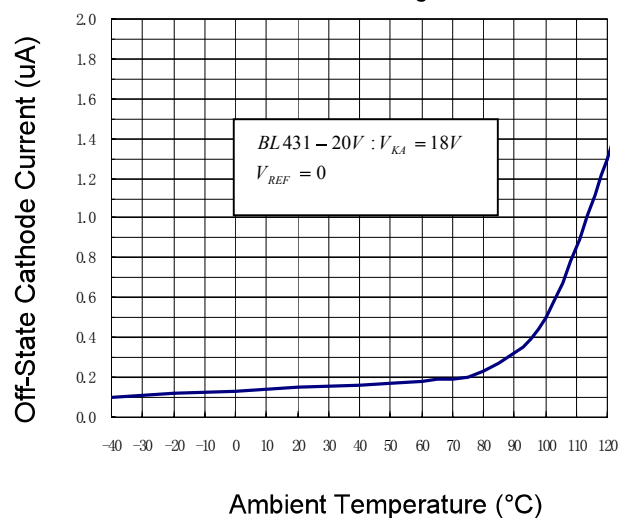
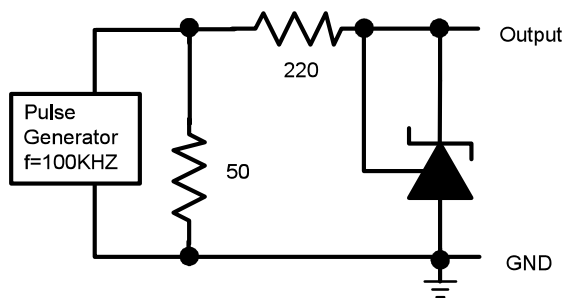

Figure 12. Off-state Cathode Current vs. Ambient Temperature

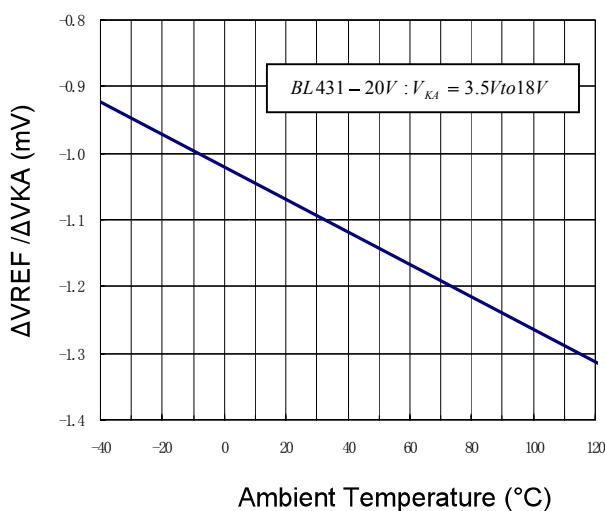

Figure 13. Ratio of Delta Reference Voltage to the Ratio of Delta Cathode Voltage

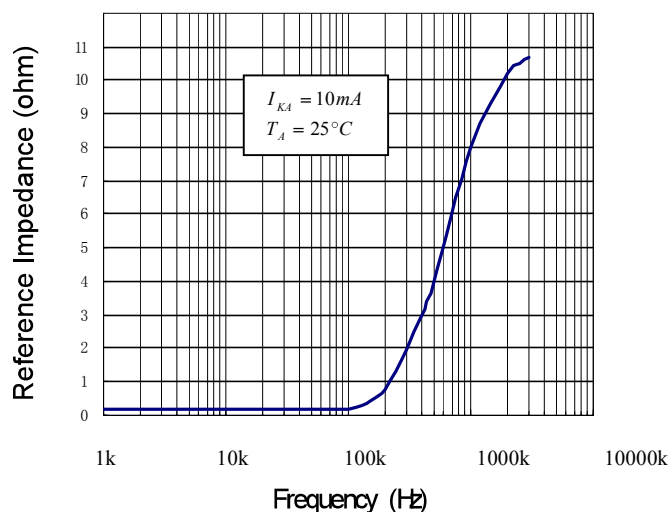
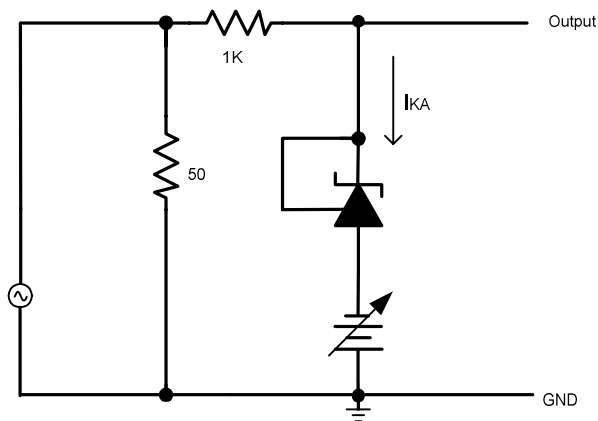

Figure 14. Reference Impedance vs. Frequency



## Typical Applications

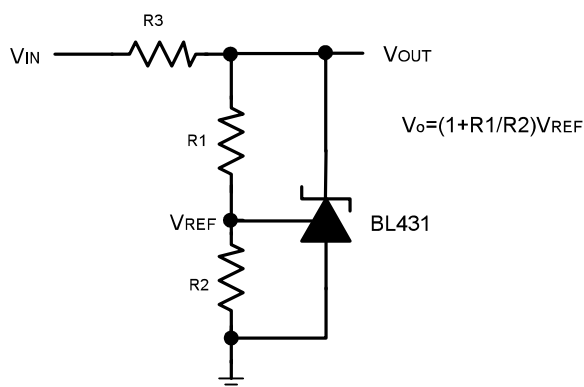

Figure 15. Shunt Regulator

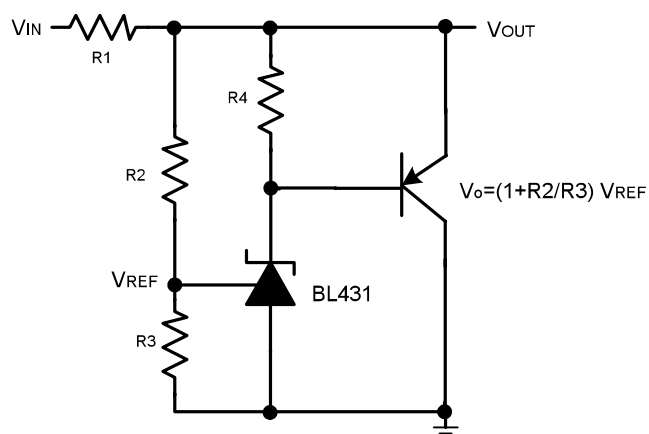

Figure 16. High Current Shunt Regulator

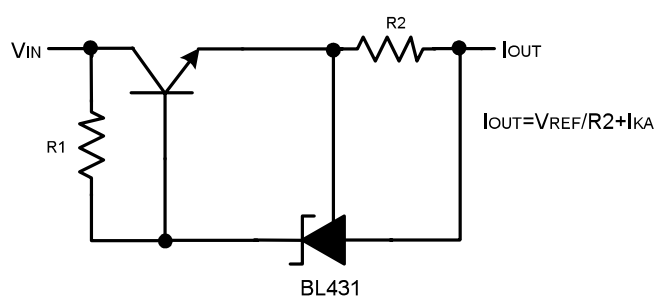

Figure 17. Current Source or Current Limit

## Typical Applications (Continued)

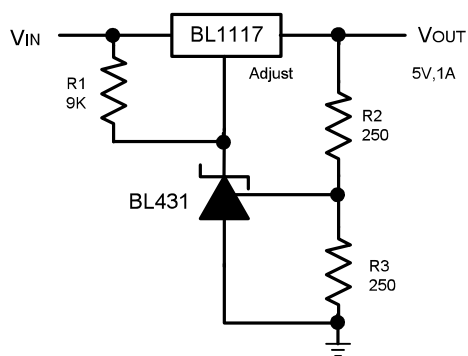
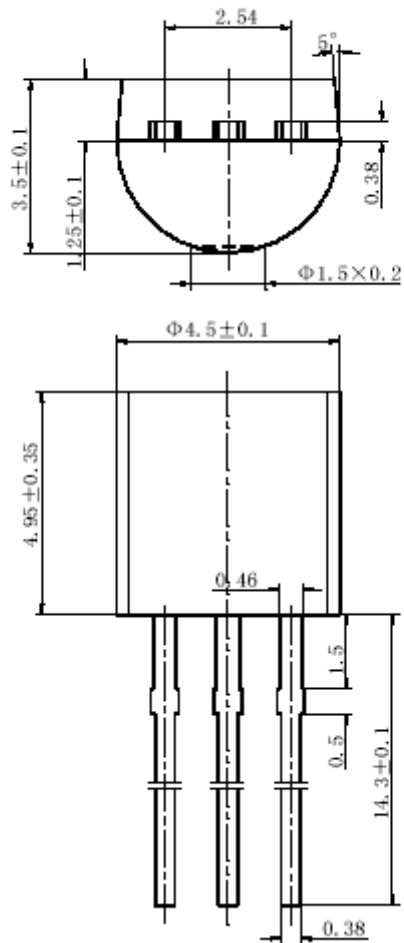

Figure 18. Precision 5V 1A Regulator



Mechanical Dimensions

TO-92





Mechanical Dimensions(Continued)

SOT-89

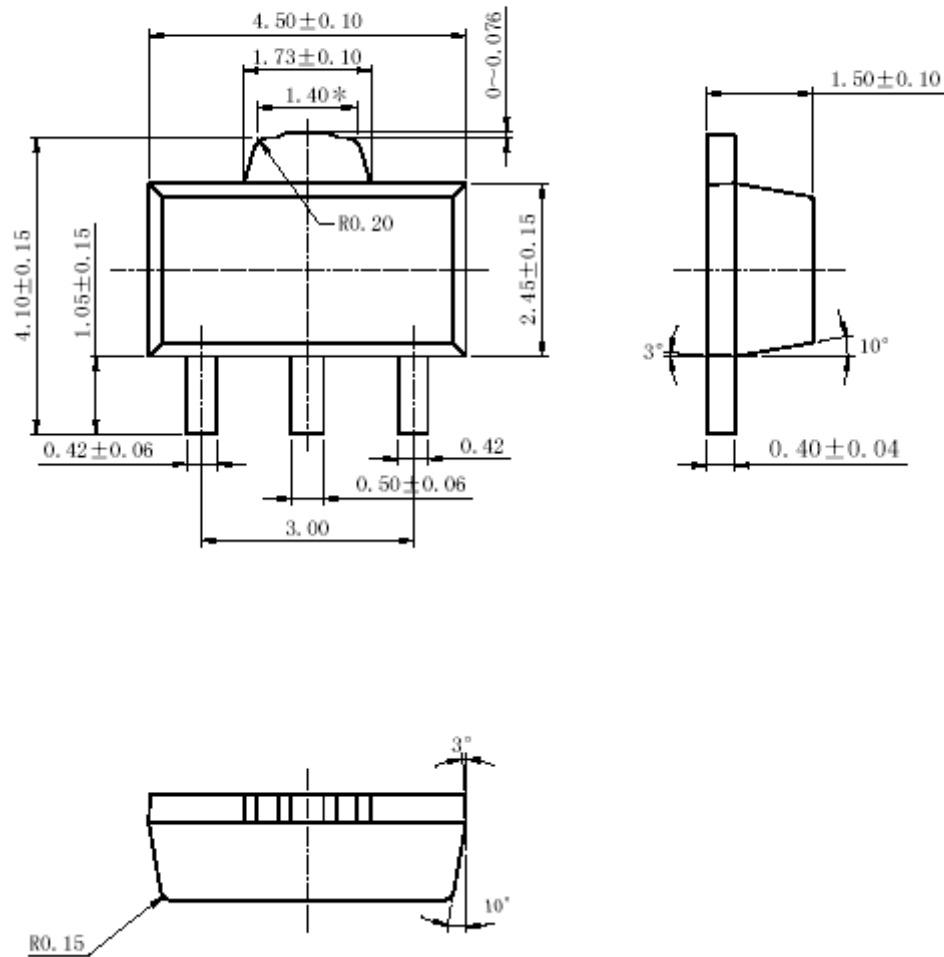

**Mechanical Dimensions(Continued)**

**SOIC-8**

