

# Large 5 X 7 Dot Matrix Alphanumeric Displays 17.3/26.5 mm Character Heights

## Technical Data

**HDSP-440X Series**  
**HDSP-450X Series**  
**HDSP-470X Series**  
**HDSP-510X Series**  
**HDSP-540X Series**  
**HDSP-L10X Series**  
**HDSP-L20X Series**  
**HDSP-M10X Series**

### Features

- Multiple Colors Available
- Large Character Height
- 5 X 7 Dot Matrix Font
- Viewable Up to 18 Meters (26.5 mm Display)
- X-Y Stackable
- Ideal for Graphics Panels
- Available in Common Row Anode and Common Row Cathode Configurations
- AlGaAs Displays Suitable for Low Power or Bright Ambients

Typical Intensity 1650 mcd  
at 2 mA Average Drive  
Current

- Categorized for Intensity
- Mechanically Rugged
- Green Categorized for Color

### Description

The large 5 X 7 dot matrix alphanumeric display family consists of 26.5 mm (1.04 inch) and 17.3 mm (0.68 inch) character height packages. These devices have excellent viewability; the 26.5 mm character can be read at up to 18 meters (12 meters for the 0.68 inch part).

The 26.5 mm font has a 10.2 mm (0.4 inch) dual-in-line (DIP) configuration, while the 17.3 mm font has an industry standard 7.6 mm (0.3 inch) DIP configuration.



Applications include electronic instrumentation, computer peripherals, point of sale terminals, weighing scales, and industrial electronics.

### Devices

Standard Red	AlGaAs Red	High Efficiency Red	High Performance Green	Description
HDSP-4701	HDSP-L101	HDSP-L201	HDSP-5401	17.3 mm Common Row Anode
HDSP-4703	HDSP-L103	HDSP-L203	HDSP-5403	17.3 mm Common Row Cathode
HDSP-4401	HDSP-M101	HDSP-4501	HDSP-5101	26.5 mm Common Row Anode
HDSP-4403	HDSP-M103	HDSP-4503	HDSP-5103	26.5 mm Common Row Cathode

### Package Dimensions HDSP-470X/L10X/L20X/540X Series

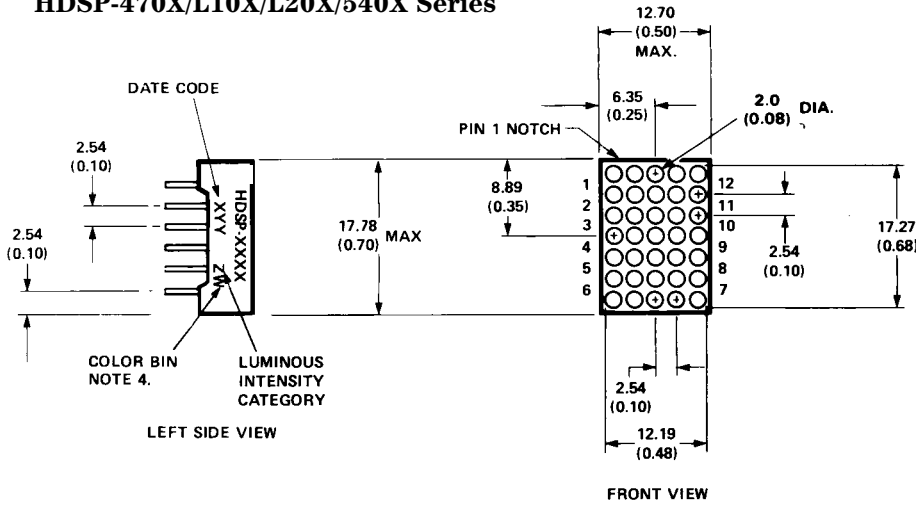

- NOTES:  
 1. ALL DIMENSIONS IN MILLIMETRES (INCHES).  
 2. ALL UNTOLERANCED DIMENSIONS ARE FOR REFERENCE ONLY.  
 3. A NOTCH ON SCRAMBLER SIDE DENOTES PIN 1.  
 4. FOR GREEN ONLY.

PIN	FUNCTION	
	HDSP-4701/-5401/ L101/L201	HDSP-4703/-5403/ L103/L203
1	COLUMN 1 CATHODE	ROW 1 CATHODE
2	ROW 3 ANODE	ROW 2 CATHODE
3	COLUMN 2 CATHODE	COLUMN 2 ANODE
4	ROW 5 ANODE	COLUMN 1 ANODE
5	ROW 6 ANODE	ROW 6 CATHODE
6	ROW 7 ANODE	ROW 7 CATHODE
7	COLUMN 4 CATHODE	COLUMN 3 ANODE
8	COLUMN 5 CATHODE	ROW 5 CATHODE
9	ROW 4 ANODE	COLUMN 4 ANODE
10	COLUMN 3 CATHODE	ROW 4 CATHODE
11	ROW 2 ANODE	ROW 3 CATHODE
12	ROW 1 ANODE	COLUMN 5 ANODE

### HDSP-440X/M10X/450X/510X Series

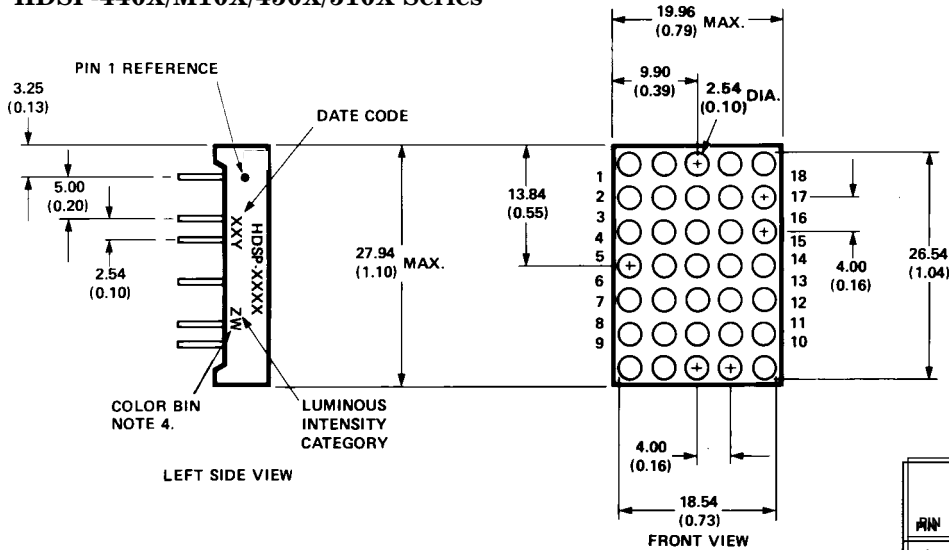

- NOTES:  
 1. ALL DIMENSIONS IN MILLIMETRES (INCHES).  
 2. ALL UNTOLERANCED DIMENSIONS ARE FOR REFERENCE ONLY.  
 3. A BLACK DOT ON SCRAMBLER SIDE INDICATES PIN 1.  
 4. FOR GREEN ONLY.

PIN	FUNCTION	
	HDSP-4401/-M101/ -4501-5101	HDSP-4403/-M103/ -4503-5103
1	COLUMN 1 CATHODE	ROW 1 CATHODE
2	NO PIN	NO PIN
3	ROW 3 ANODE	COLUMN 3 ANODE
4	COLUMN 2 CATHODE	ROW 3 CATHODE
5	NO PIN	NO PIN
6	ROW 5 ANODE	COLUMN 1 ANODE
7	NO PIN	NO PIN
8	ROW 6 ANODE	COLUMN 2 ANODE
9	ROW 7 ANODE	ROW 7 CATHODE
10	COLUMN 3 CATHODE	ROW 6 CATHODE
11	COLUMN 5 CATHODE	COLUMN 4 ANODE
12	NO PIN	NO PIN
13	ROW 4 ANODE	ROW 5 CATHODE
14	NO PIN	NO PIN
15	COLUMN 4 CATHODE	ROW 4 CATHODE
16	ROW 2 ANODE	ROW 2 CATHODE
17	NO PIN	NO PIN
18	ROW 1 ANODE	COLUMN 5 ANODE

## Internal Circuit Diagrams

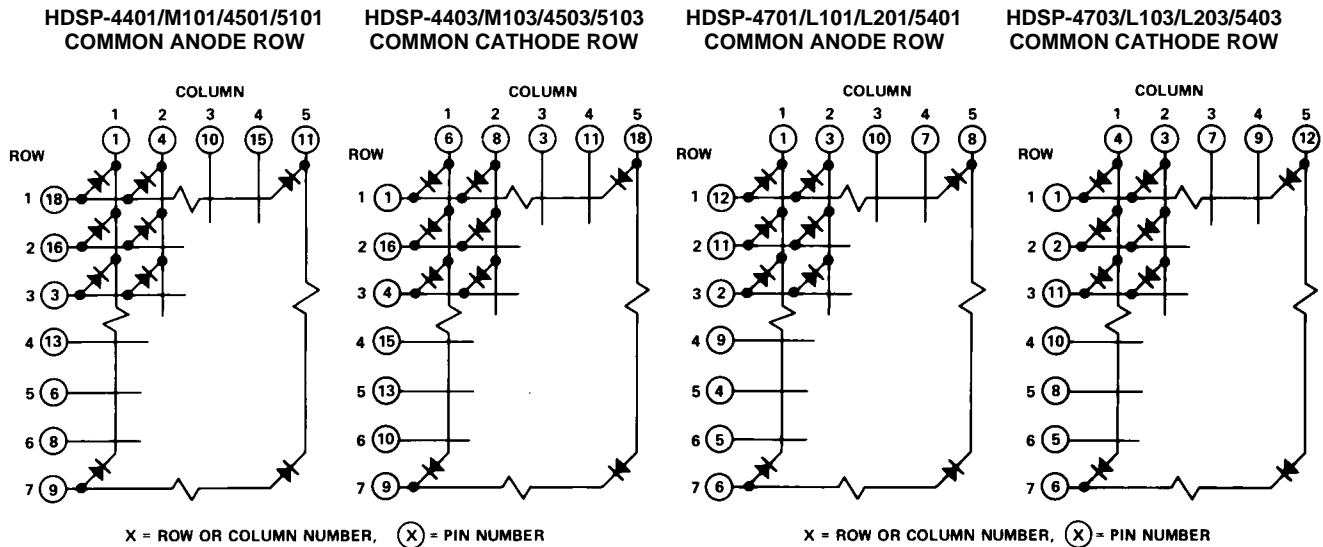

## Absolute Maximum Ratings at 25°C

Description	HDSP-470X/ 440X Series	HDSP-L10X/ M10X Series	HDSP-L20X/ 450X Series	HDSP-540X/ 510X Series
Average Power per Dot ( $T_A = 25^\circ\text{C}$ ) <sup>[1]</sup>	75 mW			
Peak Forward Current per Dot ( $T_A = 25^\circ\text{C}$ ) <sup>[1,2]</sup>	125 mA	125 mA	90 mA	90 mA
Average Forward Current per Dot ( $T_A = 25^\circ\text{C}$ ) <sup>[1,3]</sup>	32 mA	23 mA	15 mA	15 mA
Operating Temperature Range	-40°C to +85°C	-20°C to +85°C	-40°C to +85°C	-20°C to +85°C
Storage Temperature Range	-40°C to +85°C			
Lead Solder Temperature (1.59 mm [0.062 in.] below seating plane)	260°C for 3 s			

### Notes:

1. Average power is based on 20 dots per character. Total package power dissipation should not exceed 1.5 W.
2. Do not exceed maximum average current per dot.
3. For the HDSP-440X/470X series displays, derate maximum average current above 35°C at 0.43 mA/°C. For the HDSP-L10X/M10X series displays, derate maximum average current above 35°C at 0.31 mA/°C. For the HDSP-L20X/450X series and HDSP-540X/510X series displays, derate maximum average current above 35°C at 0.2 mA/°C. This derating is based on a device mounted in a socket having a thermal resistance junction to ambient of 50°C/W per package.

## Electrical/Optical Characteristics at $T_A = 25^\circ\text{C}$

### Standard Red HDSP-440X/470X Series

Description	Symbol	Test Conditions	Min.	Typ.	Max.	Units
Luminous Intensity/Dot <sup>[4]</sup> (Digit Average) HDSP-470X (17.3 mm) HDSP-440X (26.5 mm)	$I_V$	100 mA pk: 1 of 5 Duty Factor (20 mA Avg.)	360 400	770 800		$\mu\text{cd}$
Peak Wavelength	$\lambda_{\text{PEAK}}$			655		nm
Dominant Wavelength <sup>[5]</sup>	$\lambda_d$			640		nm
Forward Voltage	$V_F$	$I_F = 100 \text{ mA}$		1.8	2.2	V
Reverse Voltage <sup>[6]</sup>	$V_R$	$I_R = 100 \mu\text{A}$	3.0	12		V
Temperature Coefficient of $V_F$	$\Delta V_F / ^\circ\text{C}$			-2.0		mV/ $^\circ\text{C}$
Thermal Resistance LED Junction-to-Pin per package HDSP-470X HDSP-440X	$R_{\theta\text{J-PIN}}$			15 13		$^\circ\text{C/W/}$ PACK

### AlGaAs Red HDSP-L10X/M10X Series

Description	Symbol	Test Conditions	Min.	Typ.	Max.	Units
Luminous Intensity/Dot <sup>[4]</sup> (Digit Average) HDSP-L10X (17.3 mm) HDSP-M10X (26.5 mm)	$I_V$	10 mA pk: 1 of 5 Duty Factor (2 mA Avg.)	730 760	1650 1850		$\mu\text{cd}$
Luminous Intensity/Dot <sup>[4]</sup> (Digit Average) HDSP-L10X HDSP-M10X	$I_V$	30 mA pk: 1 of 14 Duty Factor (2.1 mA Avg.)		1750 1980		$\mu\text{cd}$
Peak Wavelength	$\lambda_{\text{PEAK}}$			645		nm
Dominant Wavelength <sup>[5]</sup>	$\lambda_d$			637		nm
Forward Voltage	$V_F$	$I_F = 10 \text{ mA}$		1.7	2.1	V
Reverse Voltage <sup>[6]</sup>	$V_R$	$I_R = 100 \mu\text{A}$	3.0	15.0		V
Temperature Coefficient of $V_F$	$\Delta V_F / ^\circ\text{C}$			-2.0		mV/ $^\circ\text{C}$
Thermal Resistance LED Junction-to-Pin per package HDSP-L10X HDSP-M10X	$R_{\theta\text{J-PIN}}$			20 18		$^\circ\text{C/W/}$ PACK

**High Efficiency Red HDSP-450X/L20X Series**

Description	Symbol	Test Conditions	Min.	Typ.	Max.	Units
Luminous Intensity/Dot <sup>[4]</sup> (Digit Average) HDSP-L20X (17.3 mm) HDSP-450X (26.5 mm)	I <sub>V</sub>	50 mA pk: 1 of 5 Duty Factor (10 mA Avg.)	1150	2800		μcd
			1400	3500		
Luminous Intensity/Dot <sup>[4]</sup> (Digit Average) HDSP-L20X HDSP-450X	I <sub>V</sub>	30 mA pk: 1 of 14 Duty Factor (2.1 mA Avg.)		740		μcd
				930		
Peak Wavelength	λ <sub>PEAK</sub>			635		nm
Dominant Wavelength <sup>[5]</sup>	λ <sub>d</sub>			626		nm
Forward Voltage	V <sub>F</sub>	I <sub>F</sub> = 50 mA		2.6	3.5	V
Reverse Voltage <sup>[6]</sup>	V <sub>R</sub>	I <sub>R</sub> = 100 μA	3.0	25.0		V
Temperature Coefficient of V <sub>F</sub>	ΔV <sub>F</sub> /°C			-2.0		mV/°C
Thermal Resistance LED Junction-to-Pin per package HDSP-L20X HDSP-450X	Rθ <sub>J-PIN</sub>			15		°C/W/ PACK
				13		

**High Performance Green HDSP-540X/510X Series**

Description	Symbol	Test Conditions	Min.	Typ.	Max.	Units
Luminous Intensity/Dot <sup>[4]</sup> (Digit Average) HDSP-540X (17.3 mm) HDSP-510X (26.5 mm)	I <sub>V</sub>	50 mA pk: 1 of 5 Duty Factor (10 mA Avg.)	1290	4000		μcd
			1540	4500		
Luminous Intensity/Dot <sup>[4]</sup> (Digit Average) HDSP-540X HDSP-510X	I <sub>V</sub>	30 mA pk: 1 of 14 Duty Factor (2.1 mA Avg.)		570		μcd
				630		
Peak Wavelength	λ <sub>PEAK</sub>			566		nm
Dominant Wavelength <sup>[5,7]</sup>	λ <sub>d</sub>			571		nm
Forward Voltage	V <sub>F</sub>	I <sub>F</sub> = 50 mA		2.6	3.5	V
Reverse Voltage <sup>[6]</sup>	V <sub>R</sub>	I <sub>R</sub> = 100 μA	3.0	25.0		V
Temperature Coefficient of V <sub>F</sub>	ΔV <sub>F</sub> /°C			-2.0		mV/°C
Thermal Resistance LED Junction-to-Pin per package HDSP-540X HDSP-510X	Rθ <sub>J-PIN</sub>			15		°C/W/ PACK
				13		

**Notes:**

- The displays are categorized for luminous intensity with the intensity category designated by a letter on the left hand side of the package. The luminous intensity minimum and categories are determined by computing the numerical average of the individual dot intensities.
- The dominant wavelength is derived from the C.I.E. Chromaticity diagram and is that single wavelength which defines the color of the device.
- Typical specification for reference only. Do not exceed absolute maximum ratings.
- The displays are categorized for dominant wavelength with the category designated by a number adjacent to the intensity category letter.

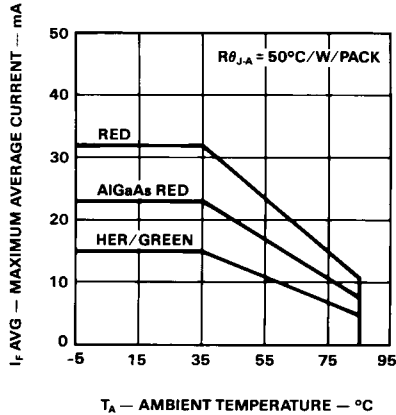

Figure 1. Maximum Allowable Average Current Per Dot as a Function of Ambient Temperature.

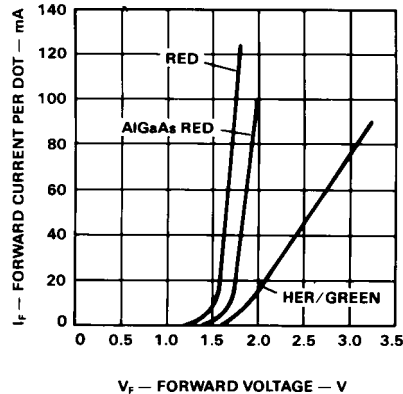

Figure 2. Forward Current vs. Forward Voltage.

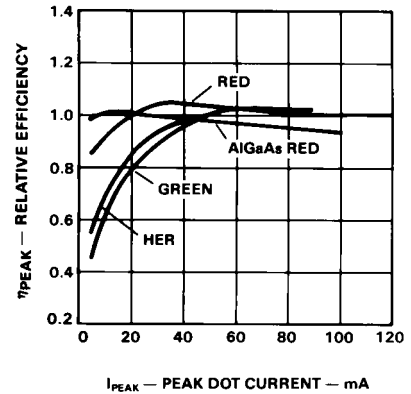

Figure 3. Relative Efficiency (Luminous Intensity per Unit Dot) vs. Peak Current per Dot.

## Operational Considerations

### Electrical Description

These display devices are composed of light emitting diodes, with the light from each LED optically stretched to form individual dots.

These display devices are well suited for strobed operation. The typical forward voltage values can be scaled from Figure 2. These values should be used to calculate the current limiting resistor value and the typical power dissipation. Expected maximum  $V_F$  values, for driver circuit design and maximum power dissipation, may be calculated using the following  $V_{FMAX}$  models:

Red (HDSP-440X/470X):

$$V_{FMAX} = 1.55 \text{ V} + I_{PEAK}(6.5 \Omega)$$

For  $I_{PEAK} \geq 5 \text{ mA}$

AlGaAs Red

(HDSP-L10X/M10X):

$$V_{FMAX} = 1.8 \text{ V} + I_{PEAK}(20 \Omega)$$

For  $I_{PEAK} \leq 20 \text{ mA}$

$$V_{FMAX} = 2.0 \text{ V} + I_{PEAK}(10 \Omega)$$

For  $I_{PEAK} \geq 20 \text{ mA}$

HER (HDSP-450X/L20X):

$$V_{FMAX} = 1.75 \text{ V} + I_{PEAK}(35 \Omega)$$

For  $I_{PEAK} \geq 5 \text{ mA}$

Green (HDSP-540X/510X):

$$V_{FMAX} = 1.75 \text{ V} + I_{PEAK}(38 \Omega)$$

For  $I_{PEAK} \geq 5 \text{ mA}$

Figure 3 allows the designer to calculate the luminous intensity at different peak and average currents. The following equation calculates intensity at different peak and average currents:

$$I_V \text{ AVG} = (I_F \text{ AVG} / I_F \text{ AVG DATA SHEET})(\eta_{PEAK})(I_V \text{ DATA SHEET})$$

Where:

$I_F \text{ AVG}$  is the desired time averaged LED current.

$I_F \text{ AVG DATA SHEET}$  is the time averaged data sheet test current for  $I_V \text{ DATA SHEET}$ .

$\eta_{PEAK}$  is the relative efficiency at the peak current, scaled from Figure 3.

$I_V \text{ DATA SHEET}$  is the time averaged data sheet luminous intensity, resulting from  $I_F \text{ AVG DATA SHEET}$ .

$I_F \text{ AVG}$  is the calculated time averaged luminous intensity resulting from  $I_F \text{ AVG}$ .

For example, what is the luminous intensity of an AlGaAs Red (HDSP-L10X) driven at 50 mA peak 1/5 duty factor?

$$I_F \text{ AVG} = 50 \text{ mA} * 0.2 = 10 \text{ mA}$$

$$I_F \text{ AVG DATA SHEET} = 2 \text{ mA}$$

$$\eta_{PEAK} = 0.98$$

$$I_V \text{ DATA SHEET} = 1650 \mu\text{cd}$$

Therefore

$$I_V \text{ AVG} = (10 \text{ mA} / 2 \text{ mA})(0.98)(1650 \mu\text{cd}) = 8085 \mu\text{cd}$$

### Thermal Considerations

The device thermal resistance may be used to calculate the junction temperature of the central LED. The equation below calculates the junction temperature of the central (hottest) LED.

$$\begin{aligned} T_J &= T_A + (P_D)(R_{\theta_{J-A}})(N) \\ P_D &= (V_{F\text{MAX}})(I_{F\text{AVG}}) \\ R_{\theta_{J-A}} &= R_{\theta_{J-PIN}} + R_{\theta_{PIN-A}} \end{aligned}$$

$T_J$  is the junction temperature of the central LED.

$T_A$  is the ambient temperature.

$P_D$  is the power dissipated by one LED.

$N$  is the number of LEDs ON per character.

$V_{F\text{MAX}}$  is calculated using the appropriate  $V_F$  model.

$R_{\theta_{J-A}}$  is the package thermal resistance from the central LED to the ambient.

$R_{\theta_{J-PIN}}$  is the package thermal resistance from the central LED to pin.

$R_{\theta_{PIN-A}}$  is the package thermal resistance from the pin to the ambient.

For example, what is the maximum ambient temperature an HDSP-L10X can operate with the following conditions:

$$\begin{aligned} I_{PEAK} &= 125 \text{ mA} \\ I_{F\text{AVG}} &= 10 \text{ mA} \\ R_{\theta_{J-A}} &= 50^\circ\text{C/W} \\ N &= 35 \\ T_{J\text{MAX}} &= 110^\circ\text{C} \end{aligned}$$

$$\begin{aligned} V_{F\text{MAX}} &= 2.0 \text{ V} + (0.125 \text{ A})(10) \\ &= 3.25 \text{ V} \\ P_D &= (3.25 \text{ V})(0.01 \text{ A}) \\ &= 0.0325 \text{ W} \\ T_A &= 110^\circ\text{C} - \\ &\quad (50^\circ\text{C/W})(0.0325 \text{ W})(35) \\ &= 53^\circ\text{C} \end{aligned}$$

The maximum number of dots ON for the ASCII character set is 20. What is the maximum ambient temperature an HDSP-L10X can operate with the following conditions:

$$\begin{aligned} I_{PEAK} &= 125 \text{ mA} \\ I_{F\text{AVG}} &= 10 \text{ mA} \\ R_{\theta_{J-A}} &= 50^\circ\text{C/W} \\ N &= 20 \\ T_{J\text{MAX}} &= 110^\circ\text{C} \end{aligned}$$

$$\begin{aligned} V_{F\text{MAX}} &= 3.25 \text{ V} \\ P_D &= 0.0325 \text{ W} \\ T_A &= 110^\circ\text{C} - \\ &\quad (50^\circ\text{C/W})(0.0325 \text{ W})(20) \\ &= 77^\circ\text{C} \end{aligned}$$

Therefore, the maximum ambient temperature can be increased by reducing the average number of dots ON from 35 to 20 dots ON per display.

### Contrast Enhancement

For information on contrast enhancement please see Application Note 1015.

### Soldering/Cleaning

For Soldering/Cleaning information on soldering LEDs please refer to Application Note 1027.

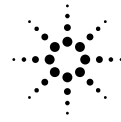

**Agilent Technologies**

Innovating the HP Way

*[www.semiconductor.agilent.com](http://www.semiconductor.agilent.com)*

Data subject to change.

Copyright © 1999 Agilent Technologies, Inc.

Obsoletes 5963-7392E

5964-6373E (11/99)