

# ULN3800A ULN3800EP



IECQ MFG.  
APPROVAL

## FMX

## FM/FMX® STEREO DECODERS

**ULN3800A**

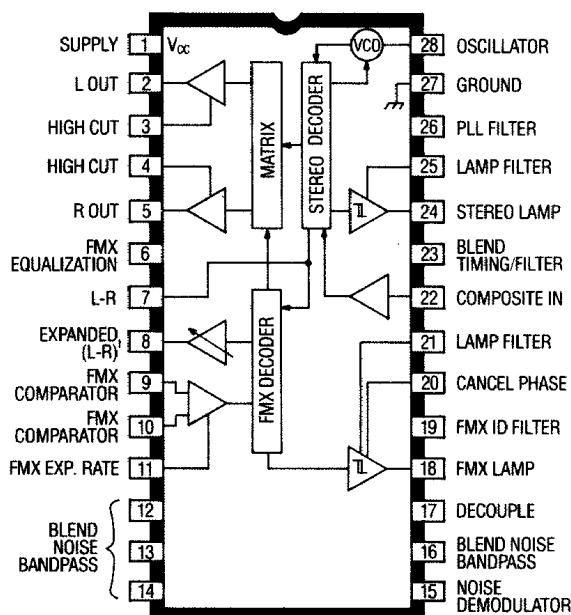

Dwg. PS-008

Noise-free FM-stereo reception, even of stereo stations that were previously too noisy to listen to without switching to mono, is provided by the ULN3800A and ULN3800EP FM/FMX stereo decoders. With a minimum number of external components the FMX (extended-range FM stereo) system can result in as much as a 14 dB improvement in signal-to-noise ratio, a dynamic range superior to that of standard FM stereo, and can provide a 45 dB mid-band separation even under low signal-level conditions.

The FMX companding noise-reduction system leaves the standard L + R, 19 kHz pilot, and L-R signals unaltered but adds a second L-R signal in quadrature. The quadrature signal is ignored by ordinary FM-stereo receivers. The FMX stereo decoder system uses a low-level 10 Hz quadrature pilot signal for identification and switching purposes. The system is fully-compatible with standard FM and FM-stereo transmissions.

These devices also include additional features (beyond the standard FMX system improvements) to further improve FM and FMX stereo performance, especially under poor reception conditions.

A dual bandwidth phase-locked loop switches to a very narrow bandwidth to assure optimal phase stability under noisy reception conditions. Noise-actuated blending adjusts the stereo separation as a function of signal-to-noise ratio to reduce the background noise for low-signal levels and eliminate transition problems at the stereo/mono switch point. The regenerated 19 kHz reference and 38 kHz carrier are free from 3rd and 5th harmonics to improve adjacent channel rejection and signal-to-noise ratio as well as providing good rejection of ARI (Auto Radio Information), RDS (Radio Data System), and other data tones.

The ULN3800A is a 28-pin dual in-line plastic package with a copper lead frame that eliminates many decoupling problems. The ULN3800EP is a 28-lead PLCC for surface mount applications.

### ABSOLUTE MAXIMUM RATINGS

Supply Voltage, V <sub>CC</sub>	13 V
Package Power Dissipation, P <sub>D</sub>	1.0 W
Operating Temperature Range, T <sub>A</sub>	-40°C to +85°C
Storage Temperature Range, T <sub>S</sub>	-65°C to +150°C

Note that the ULN3800A (dual in-line package) and ULN3800EP (plastic leaded chip carrier) are electrically identical and share a common pin number assignment.

### FEATURES

- Reduced Car-Stereo Multi-Path Effects
- Increased FM-Stereo Range
- Improved Adjacent-Channel Rejection
- Good ARI/RDS Rejection
- 19 kHz Pilot & 10 Hz ID Canceling
- Noise-Actuated Blending and High Cut
- Ceramic Resonator Controlled Oscillator
- Automatic Stereo/Mono and FM/FMX Switching
- 28-Pin Plastic DIP or 28-Lead PLCC

# ULN3800A AND ULN3800EP FM/FMX STEREO DECODERS

## ULN3800EP

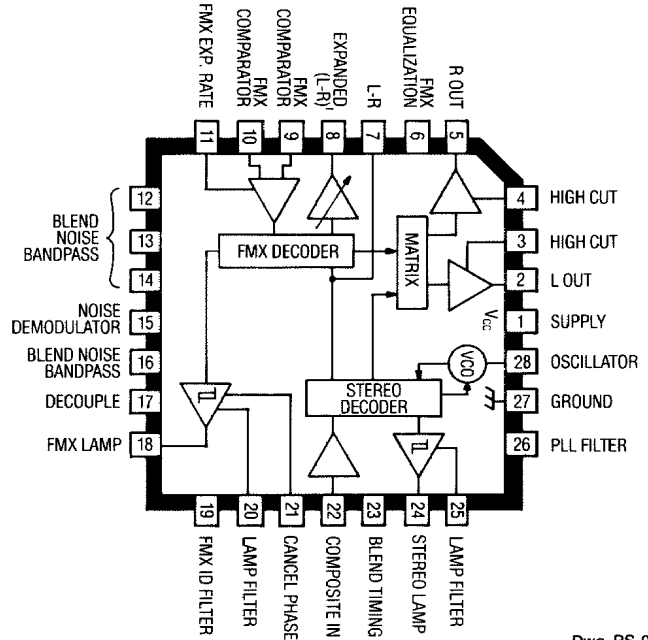

Dwg. PS-009

Broadcast Technology Partners owns patents covering the FMX system and requires a license for the manufacture and sale of products incorporating these devices. The purchase of the ULN3800A or ULN3800EP FM/FMX stereo decoders do not carry with such purchase any license by implication, estoppel or otherwise, under any patent rights of Broadcast Technology Partners or others covering any combination of these decoders with other elements including use in a radio receiver. Upon application by an interested party, licenses are available from Broadcast Technology Partners on its patents applicable to FMX stereo receivers.

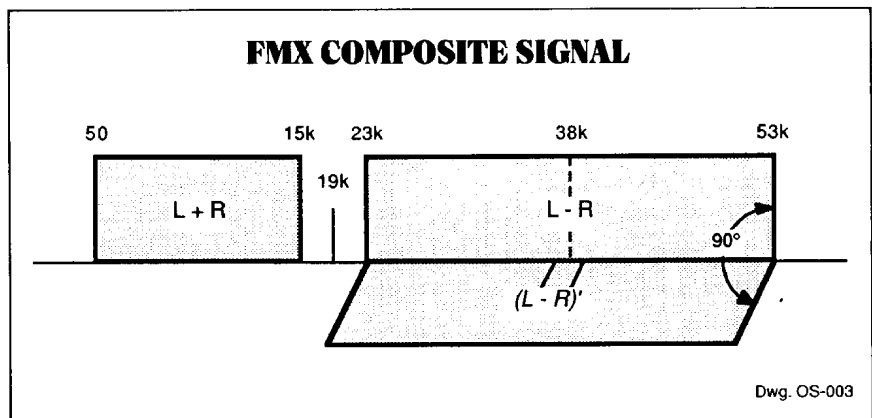

Dwg. OS-003

# SPRAGUE

115 Northeast Cutoff, Box 15036  
Worcester, Massachusetts 01615-0036 (508) 853-5000  
Copyright © 1989 Sprague Electric Company, April 1989

# ULN3800A AND ULN3800EP FM/FMX STEREO DECODERS

Dwg. FS-006

## FUNCTIONAL BLOCK DIAGRAM

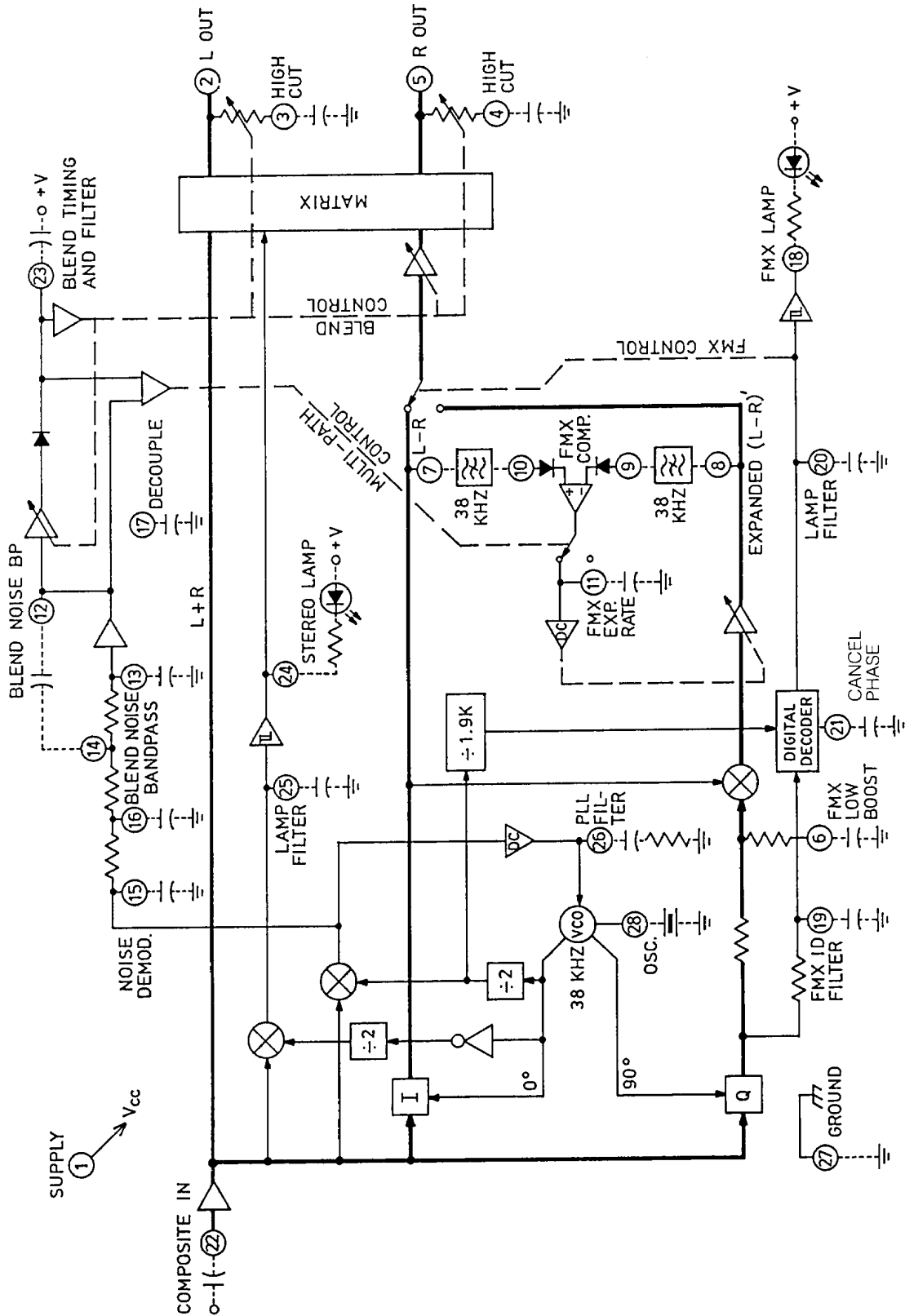

SEMICONDUCTOR GROUP

# ULN3800A AND ULN3800EP

## FM/FMX STEREO DECODERS

**ELECTRICAL CHARACTERISTICS at  $T_A = +25^\circ\text{C}$ ,  $V_{CC} = 9.0\text{ V}$ , Composite Input = 400 mVrms (L = R, pilot OFF), Pilot Level = 40 mVrms,  $f_m = 1\text{ kHz}$ , unless otherwise specified.**

Characteristic	Test Conditions	Limits			
		Min.	Typ.	Max.	Units
Supply Voltage Range	Functional	7.5	9.0	12	V
Max. Composite Input	THD = 1.0%	—	800	—	mVrms
Input Impedance		—	25	—	k $\Omega$
Output Impedance		—	15	—	k $\Omega$
Stereo Channel Separation	$f_m = 100\text{ Hz}$	—	35	—	dB
	$f_m = 1.0\text{ kHz}$	—	35	—	dB
	$f_m = 10\text{ kHz}$	—	35	—	dB
Monaural Gain	19 kHz Pilot Level = 0	—	0	—	dB
Monaural Channel Balance	19 kHz Pilot Level = 0	—	0	$\pm 1.0$	dB
Total Harmonic Distortion (100 Hz to 1 kHz)	19 kHz Pilot = 0	—	0.05	—	%
	L or R only	—	0.1	—	%
Ultrasonic Frequency Rejection	19 kHz	—	-51	—	dB
	38 kHz	—	-45	—	dB
SCA Rejection	67 kHz (Note 2)	—	-85	—	dB
Spurious Response	114 kHz, 10% modulation	—	-65	—	dB
	190 kHz, 10% modulation	—	-65	—	dB
PLL Noise Bandwidth		—	20	—	Hz
Stereo Switch Level	19 kHz Pilot Only, Lamp ON	—	12	—	mVrms
	19 kHz Pilot Only, Lamp OFF	—	8.5	—	mVrms
Stereo Lamp Hysteresis	Lamp OFF to Lamp ON	—	3.0	—	dB
FMX Expander Response	Within 1.0 dB	0.1	—	—	ms
	Within 0.5 dB	1.0	—	—	ms
FMX Pilot Switch Level (Percent Modulation of (L-R))	10 Hz Pilot, Lamp ON	—	0.5	—	%
	10 Hz Pilot, Lamp OFF	—	0.25	—	%
FMX Lamp Turn-ON Delay		—	1.0	2.0	s
FMX Lamp Turn-OFF Delay		2.0	—	—	s
Capture Range	Pilot = 6.0 mV	—	300	—	Hz
Lock Range	Pilot = 20 mV	—	300	—	Hz
Blend Threshold	S + N/N	—	40	—	dB
Stereo & FMX Lamp Output Current	Short Circuit, Lamp ON	—	40	—	mA
	Lamp OFF, $V_{CC} = 12\text{ V}$	—	—	3.0	$\mu\text{A}$
Quiescent Supply Current	Lamp OFF	—	37	—	mA

NOTES: 1) Typical values are given for circuit design information only.

2) Measured with a stereo composite signal of 80% stereo, 10% pilot, and 10% SCA.

The information shown herein is derived from developmental samples made available for evaluation. It does not necessarily imply that the device will go into regular production.

# SPRAGUE

115 Northeast Cutoff, Box 15036  
Worcester, Massachusetts 01615-0036 (508) 853-5000

# ULN3800A AND ULN3800EP FM/FMX STEREO DECODERS

## TEST CIRCUIT AND TYPICAL APPLICATION

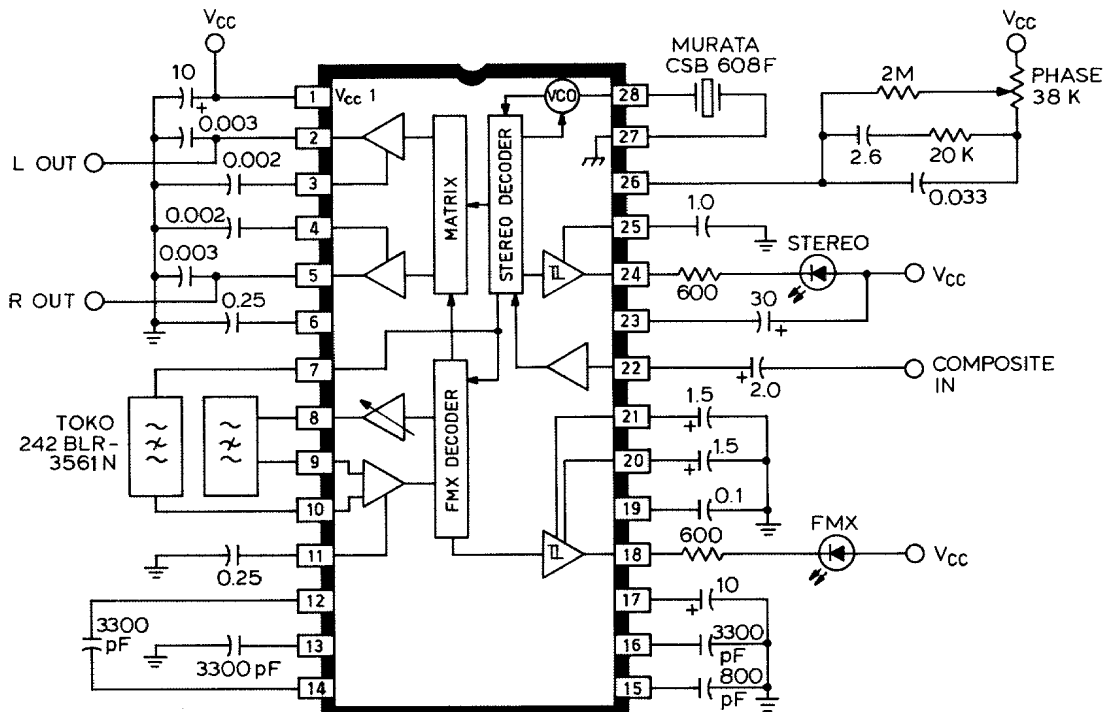

Dwg. ES-009

The typical application and circuit constants herein are included only as an example and provide no guarantee for designing equipment to be mass-produced. The information herein is believed to be accurate and reliable. However, no responsibility is assumed by Sprague Semiconductor Group for its use, nor for any infringements of patents or other rights of third parties which may result from its use.

## DETAILED FMX SYSTEM INFORMATION

Detailed technical information regarding the transmission and reception of FMX formatted signals is available from several sources:

1. T. Rucktenwold and E. Toric, "FMX Mobile Reception", IEEE Transactions on Consumer Electronics, November, 1988.
2. L. Klein, "Audio Update, Getting the Noise Out of FM", Radio-Electronics, June, 1988.
3. T. Ishikawa and M. Tanno, "FMX Decoder IC Development", IEEE Transactions on Consumer Electronics, August, 1987.
4. L. Feldman, "FMX: Long Distance Stereo, Clean as Mono", Audio Magazine, May, 1986.
5. E. Torick and T. Keller, "Improving the Signal-to-Noise Ratio and Coverage of FM Stereophonic Broadcasts", Audio Engineering Society Journal, December, 1985.
6. D. Gravereaux, D. Stebbings, J. Kadin, and A. Cugnini, "Re-entrant Compression and Adaptive Expansion for Optimized Noise Reduction", Audio Engineering Society Journal, December, 1985.

SEMICONDUCTOR GROUP

5

# ULN3800A AND ULN3800EP FM/FMX STEREO DECODERS

## ULN3800EP PLASTIC LEADED CHIP CARRIER

### DIMENSIONS IN INCHES

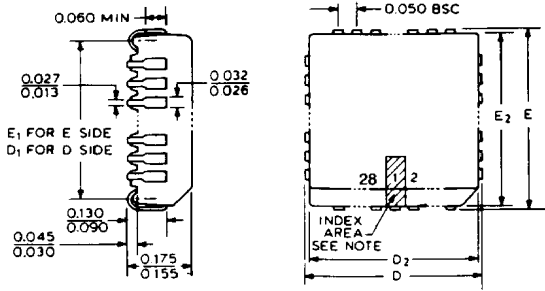

Dwg. No. A-13,644 IN

D	Overall Length	0.470/0.510
D <sub>1</sub>	Row Spacing	0.390/0.430
D <sub>2</sub>	Body Length	0.440/0.460
E	Overall Width	0.470/0.510
E <sub>1</sub>	Row Spacing	0.390/0.430
E <sub>2</sub>	Body Width	0.440/0.460
JEDEC Designation		MS-007AA

NOTE: Index is centered on "D" side.

### DIMENSIONS IN MILLIMETERS (Based on 1" = 25.40 mm)

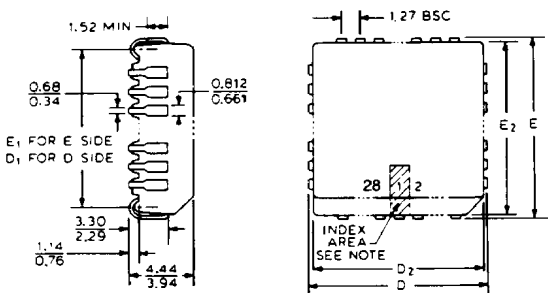

Dwg. No. A-13,644MM

D	Overall Length	11.94/12.95
D <sub>1</sub>	Row Spacing	9.91/10.92
D <sub>2</sub>	Body Length	11.18/11.68
E	Overall Width	11.94/12.95
E <sub>1</sub>	Row Spacing	9.91/10.92
E <sub>2</sub>	Body Width	11.18/11.68
JEDEC Designation		MS-007AA

NOTE: Index is centered on "D" side.

In the construction of the components described, the full intent of the specification will be met. The Sprague Electric Company, however, reserves the right to make, from time to time, such departures from the detail specifications as may be required to permit improvements in the design of its products. Components made under military approvals will be in accordance with the approval requirements.

The information included herein is believed to be accurate and reliable. However, the Sprague Electric Company assumes no responsibility for its use; nor for any infringements of patents or other rights of third parties which may result from its use.

## ULN3800A PLASTIC DIP

### DIMENSIONS IN INCHES

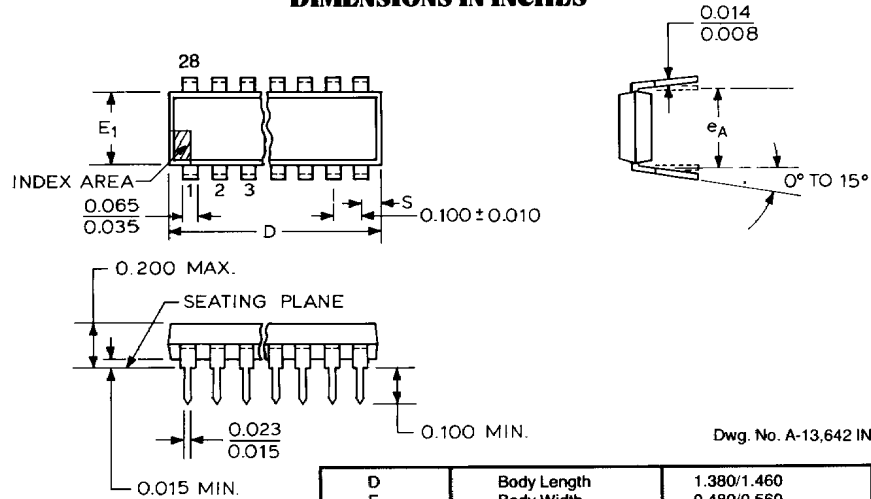

Dwg. No. A-13,642 IN

D	Body Length	1.380/1.460
E <sub>1</sub>	Body Width	0.480/0.560
e <sub>A</sub>	Row Spacing	0.600 BSC
S	Lead CL to End	0.075 REF

### DIMENSIONS IN MILLIMETERS (BASED ON 1" = 25.40 mm)

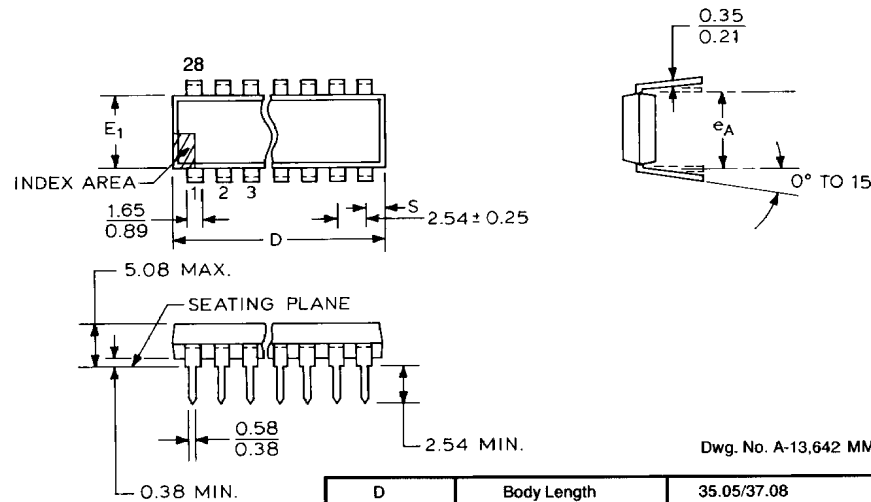

Dwg. No. A-13,642 MM

D	Body Length	35.05/37.08
E <sub>1</sub>	Body Width	12.19/14.22
e <sub>A</sub>	Row Spacing	15.24/BSC
S	Lead CL to End	1.90 REF

- A. Dimensions shown as \_\_\_\_ / \_\_\_\_ are Min./Max.
- B. Lead thickness is measured at seating plane or below.
- C. Lead spacing tolerance is non-cumulative.
- D. Exact body and lead configuration at vendor's option within limits shown.
- E. Lead gauge plane is 0.030" (0.762 mm) max. below seating plane.

# ULN3800A AND ULN3800EP FM/FMX® STEREO DECODERS

## SPRAGUE LINEAR INTEGRATED CIRCUITS FOR RADIO APPLICATIONS

Device Type	Inputs		Description	Supply Voltage Range	SMD Avail.
	AM	FM			
ULN2111A	—	10.7 MHz	FM IF and Detector	8.0-14 V	—
ULN2204A	to 1600 kHz	10.7 MHz	AM/FM Radio System	2.0-12 V	X
ULN2241A	to 30 MHz	10.7 MHz	AM/FM Signal Processor	10-16 V	—
ULN2243A	—	to 108 MHz	FM Mixer and IF	8.0-12 V	—
ULN3732B	—	—	Dual Voltage Regulator for ETR	10-16 V	—
ULN3733W	—	—	Multiple Voltage Regulator for ETR	10-16 V	—
ULN3800A	—	Composite Audio	FM/FMX® Stereo Decoder	7.5-12 V	X
ULN3819A	—	Composite Audio	FM Stereo Noise Blanker	7.5-12 V	X
ULN3827A	—	Composite Audio	Stereo Decoder w/Noise-Actuated Blend	7.5-12 V	X
ULN3834A	to 20 MHz	10.7 MHz	AM/FM Radio System	2.0-12 V	—
ULN3839A	to 30 MHz	—	AM Radio System	1.8-9.0 V	X
ULN3840A	to 30 MHz	10.7 MHz	AM/FM Signal Processor w/ $\Delta$ f Mute	8.5-16 V	—
ULN3841A	to 30 MHz	—	AM Signal Processor	6.5-16 V	X
ULN3842A	to 30 MHz	10.7 MHz	AM/FM Signal Processor w/ $\Delta$ f Mute	8.5-16 V	X
ULN3845A	to 30 MHz	—	AM Stereo Noise Blanker	7.5-12 V	X
ULN3846A	to 30 MHz	—	AM Noise Blanker	7.5-12 V	X
ULN3847A	to 20 MHz	—	AM Up-Converter	6.5-16 V	X
ULN3859A	—	10.7 MHz	FM 2nd Conv., IF, Detector, & Squelch	4.0-9.0 V	X
ULN3883A	—	10.7 MHz	FM 2nd Conv., IF, Detector, & Audio	3.0-9.0 V	X

www.DataSheet4U.com