



**70 VOLT 10 AMP RAD-HARD  
H-BRIDGE PWM MOTOR  
DRIVER/AMPLIFIER**

**4202RH**

M.S.KENNEDY CORP.

4707 Dey Road Liverpool, N.Y. 13088

(315) 701-6751

**FEATURES:**

- User Adjustable PWM Frequency
- 70 Volt, 10 Amp Capability
- Self-Contained Smart Lowside/Highside Drive Circuitry
- Internal PWM Generation, Shoot-through Protection
- Isolated Case Allows Direct Heatsinking
- On Board 5Volt Rad-Hard Regulator
- Available Fully Screened To MIL-PRF-38534 Class K and Class H
- Total Dose Rated to 100K RAD
- Logic Level High Side Enable Control
- Logic Level Disable Input

**MIL-PRF-38534 QUALIFIED  
CERTIFIED TO CLASS K**

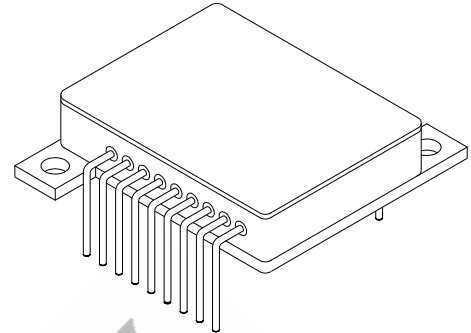

**DESCRIPTION:**

The MSK 4202RH is a radiation hardened complete H-Bridge hybrid intended for use in DC brushed motor control applications or Class D switchmode amplification in space or other severe operating environments. The design will exhibit high resistance to Single Event Effects (SEE), Single Event Gate Rupture (SEGR), total dose up to 100K RAD and neutron tolerance for military applications. All of the drive/control circuitry for the lowside and highside switches are internal to the hybrid, as well as a +5V linear regulator. The PWM circuitry is internal as well, leaving the user to only provide an analog signal for the motor speed/direction, or audio signal for switchmode audio amplification. The MSK 4202RH is packaged in a space efficient isolated 18 pin power package available in three lead form configurations that can be directly connected to a heatsink.

**EQUIVALENT SCHEMATIC**

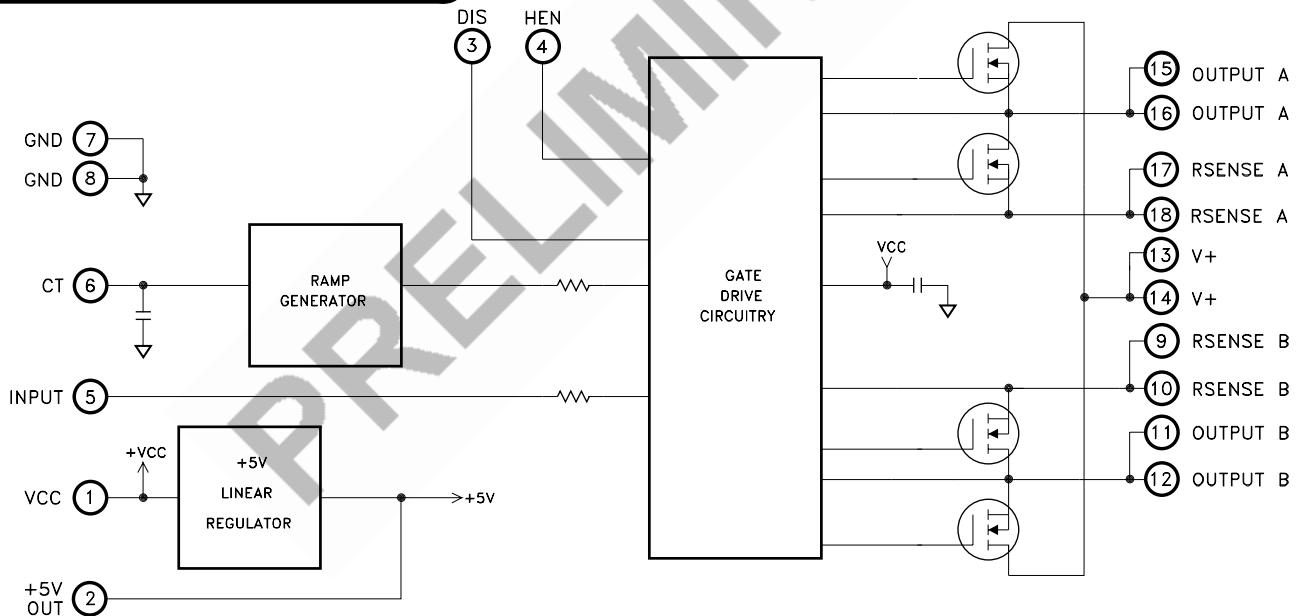

**TYPICAL APPLICATIONS**

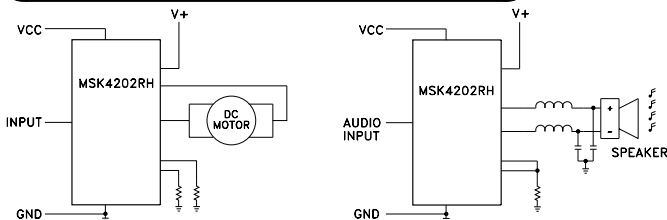

## ELECTRICAL SPECIFICATIONS

Parameter	Test Conditions ①	Subgroup Group A ④	MSK 4202RH ③			Units
			Min.	Typ.	Max.	
<b>OUTPUT CHARACTERISTICS</b>						
VDS(ON) Voltage (Each MOSFET)	ID = 10A	1	-	0.5	1.0	V
		2	-	1.0	2.0	V
		3	-	0.2	1.0	V
Instantaneous Forward Voltage, Each MOSFET ② (Intrinsic Diode)	IS = 10A	1	-	TBD	1.8	V
		2	-	TBD	1.9	V
		3	-	TBD	1.8	V
RDS (ON) each mosfet ② ⑥	ID = 10A TC = 125°C	-	-	0.075	0.1	Ω
Leakage Current, Each MOSFET ②	V+ = 70V	1	-	25	50	uA
		2	-	100	500	uA
		3	-	25	50	uA
PWM Frequency	CT = N/C	4,5,6	40	45	50	KHz
	CT = 300pF TO GND	4,5,6	TBD	20	TBD	KHz
<b>VCC SUPPLY CHARACTERISTICS</b>						
Quiescent Current	VIN = 2.5V	1,2,3	-	20	TBD	mA
+5V OUT	IOUT = 0mA	1,2,3	4.9	5.0	5.1	V
	IOUT = 100mA	1,2,3	4.75	5.0	5.25	V
<b>OUTPUT DUTY CYCLE</b>						
	VIN = 2.5VDC Both Outputs	4,5,6	40	50	60	%
VIN = 5V	Output A = 100% Duty Cycle High Output B = 0% Duty Cycle Low	7	-	Verify	-	P/F
	Output A = 0% Duty Cycle Low Output B = 100% Duty Cycle High	7	-	Verify	-	P/F
<b>SWITCHING CHARACTERISTICS ②</b>						
Rise-Time	RL = 1K A to B	-	-	75	TBD	nS
Fall-Time	RL = 1K A to B	-	-	350	TBD	nS
Dead-Time	RL = 1K A to B	-	-	100	-	nS
<b>LOGIC CONTROL INPUTS</b>						
DIS Input ②	Input Voltage LO	1,2,3	-	-	0.8	V
	Input Voltage HI	1,2,3	2.0	-	-	V
	Input Current (High or Low)	1,2,3	-	±100	±250	uA
HEN Input ②	Input Voltage LO	1,2,3	-	-	0.8	V
	Input Voltage HI	1,2,3	2.0	-	-	V
	Input Current (High or Low)	1,2,3	-	±100	±250	uA

### NOTES:

- ① VCC = 12V, V+ = 28V, RSENSE A,B = Ground, CT = N/C, DIS = 0V, HEN = N/C unless otherwise specified
- ② Guaranteed by design but not tested. Typical parameters are representative of actual device performance but are for reference only.
- ③ Devices shall be 100% tested to subgroups 1,2,3,4, and 7. Subgroup 5 and 6 testing available upon request.
- ④ Subgroup 1,4,7 TA = TC = +25°C  
2,5 TA = TC = +125°C  
3,6 TA = TC = -55°C
- ⑤ Industrial grade devices shall be 100% tested at 25°C only.
- ⑥ The internal on resistance is for the die only. This should be used for thermal calculations only.

## ABSOLUTE MAXIMUM RATINGS

V+	High Voltage Supply	70V
V <sub>CC</sub>	Logic Supply	16V
I <sub>OUT</sub>	Continuous Output Current	10A
I <sub>PK</sub>	Peak Output Current	23A
V <sub>OUT</sub>	Output Voltage Range	GND-2V min. to V+ max.
I <sub>OUT</sub>	(+5V Regulator)	500mA
V <sub>IN</sub>	Input Voltage	5.5V
V <sub>IN</sub>	Logic Input Voltage	0V to TBD

T <sub>ST</sub>	Storage Temperature Range	-65°C to +150°C
T <sub>LD</sub>	Lead Temperature Range (10 Seconds)	300°C
T <sub>C</sub>	Case Operating Temperature	-55°C to +125°C
T <sub>J</sub>	Junction Temperature	+175°C
θ <sub>Jc</sub>	Thermal Resistance (Output FETS)	2.0°C/W
	(+5Vout Regulator)	12°C/W

## APPLICATION NOTES

### MSK 4202RH PIN DESCRIPTIONS

**VCC** - Is the low voltage supply for powering internal logic and drivers for the lowside and highside MOSFETS. The supplies for the highside drivers are derived from this voltage. The +5V regulator also gets its supply voltage from this pin.

**V+** - Is the high voltage H-bridge supply. The MOSFETS obtain the drive current from this supply pin. The voltage on this pin is limited by the drive IC. The MOSFETS are rated at 100 volts. Proper by-passing to GND with sufficient capacitance to suppress any voltage transients, and to ensure removing any drooping during switching, should be done as close to the pins on the hybrid as possible.

**OUTPUT A** - Is the output pin for one half of the bridge. Increasing the input voltage causes increasing duty cycles at this output.

**OUTPUT B** - Is the output pin for the other half of the bridge. Decreasing the input voltage causes increasing duty cycles at this output.

**RSENSE A** - Is the connection for the bottom of the A half bridge. This can have a sense resistor connection to the V+ return ground for current limit sensing, or can be connected directly to ground. The maximum voltage on this pin is ±2 volts with respect to GND.

**RSENSE B** - Is the connection for the bottom of the B half bridge. This can have a sense resistor connection to the V+ return ground for current limit sensing, or can be connected directly to ground. The maximum voltage on this pin is ±2 volts with respect to GND.

**GND** - Is the return connection for the input logic and Vcc.

**INPUT** - Is an analog input for controlling the PWM pulse width of the bridge. A voltage higher than 2.5V will produce greater than 50% duty cycle pulses out of OUTPUT A. A voltage lower than 2.5V will produce greater than 50% duty cycle pulses out of OUTPUT B.

**DIS** - Is the connection for disabling all 4 output switches. DIS high overrides all other inputs. When taken low, everything functions normally. An internal pullup to Vcc will keep DIS high if left unconnected. This pin should be grounded if not used.

**HEN** - Is the connection for enabling the high side output switches. When taken low, HEN overrides other inputs and the high side switches remain off. When HEN is high, everything functions normally. An internal pullup to Vcc will keep HEN high if left unconnected.

**+5V OUT** - Is the output of the internal linear regulator. This pin should be bypassed to GND using a 4.7μF tantalum capacitor and a 0.1μF ceramic capacitor. This pin can supply up to 500mA of output current for powering other external circuitry, depending on case temperature and input voltage.

**CT** - Is a connection to the internal ramp generator. An external capacitor can be connected from this pin to GND to lower the PWM frequency. The following chart is useful to determine a capacitor for a lower PWM frequency.

CT (pF)	PWM FREQUENCY
TBD	1KHz
TBD	10KHz
TBD	15KHz
TBD	20KHz
TBD	25KHz
TBD	35KHz
TBD	40KHz

## TYPICAL SYSTEM OPERATION

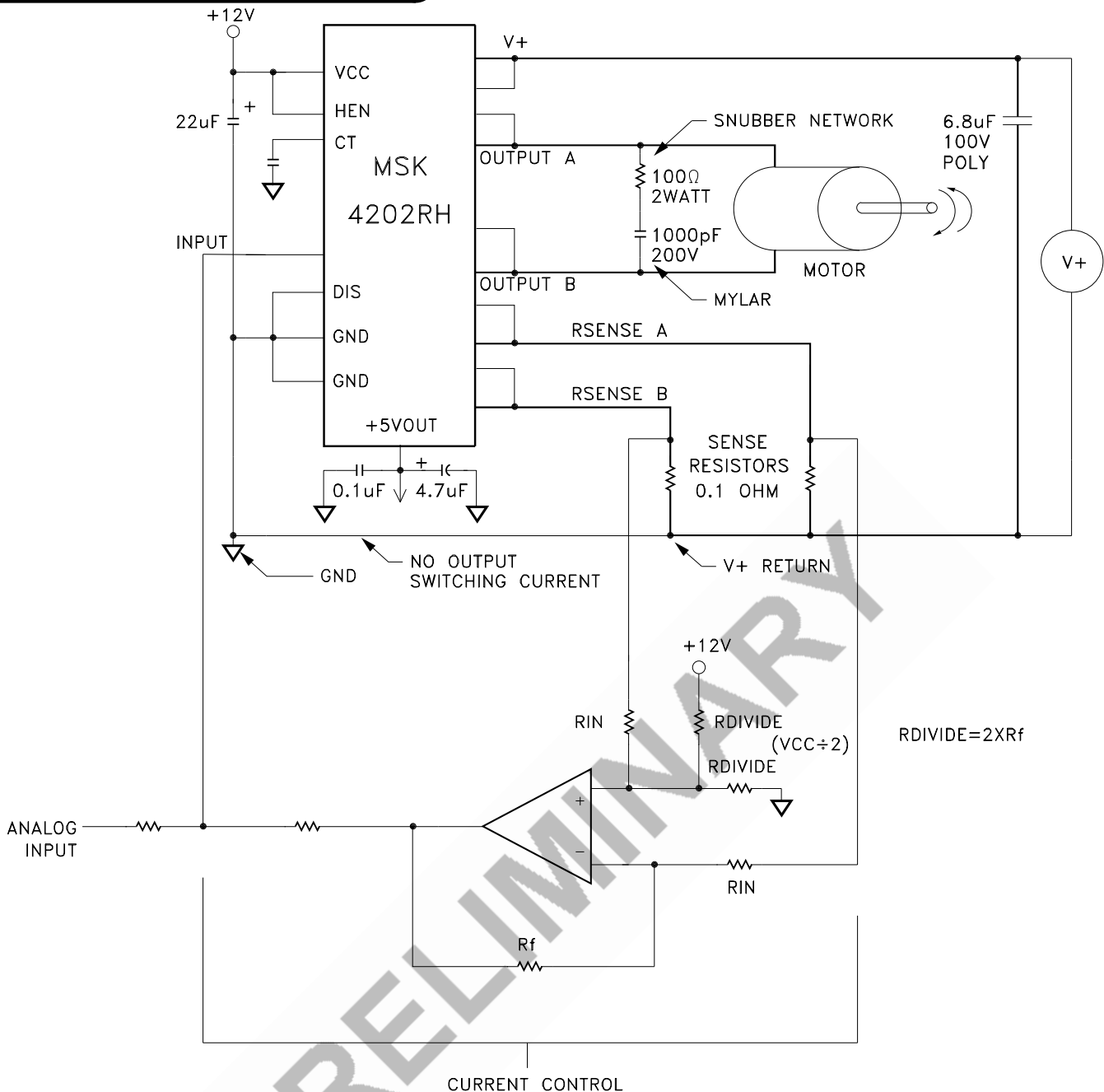

This is a diagram of a typical application of the MSK 4202RH. The design Vcc voltage is +12 volts and should have a good low ESR bypass capacitor such as a tantalum. The analog input can be an analog speed control voltage from a potentiometer, other analog circuitry or by microprocessor and a D/A converter. This analog input gets pulled by the current control circuitry in the proper direction to reduce the current flow in the bridge if it gets too high. The gain of the current control amplifier will have to be set to obtain the proper amount of current limiting required by the system.

Current sensing is done in this case by a 0.1 ohm sense resistor to sense current from both legs of the bridge separately. It is important to make the high current traces as big as possible to keep inductance down. The storage capacitor connected to the V+ and the hybrid should be large enough to provide the high energy pulse without the voltage sagging too far. A low ESR ceramic capacitor or large polypropylene capacitor will be required. Mount capacitor as close to hybrid as possible. The connection between GND and the V+ return should not be carrying any motor current. The sense resistor signal is common mode filtered as necessary to feed the limiting circuitry for the microprocessor. This application will allow full four quadrant torque control for a closed loop servo system.

A snubber network is usually required, due to the inductance in the power loop. It is important to design the snubber network to suppress any positive spikes above 70V and negative spikes below -2V with respect to GROUND.

## MECHANICAL SPECIFICATIONS

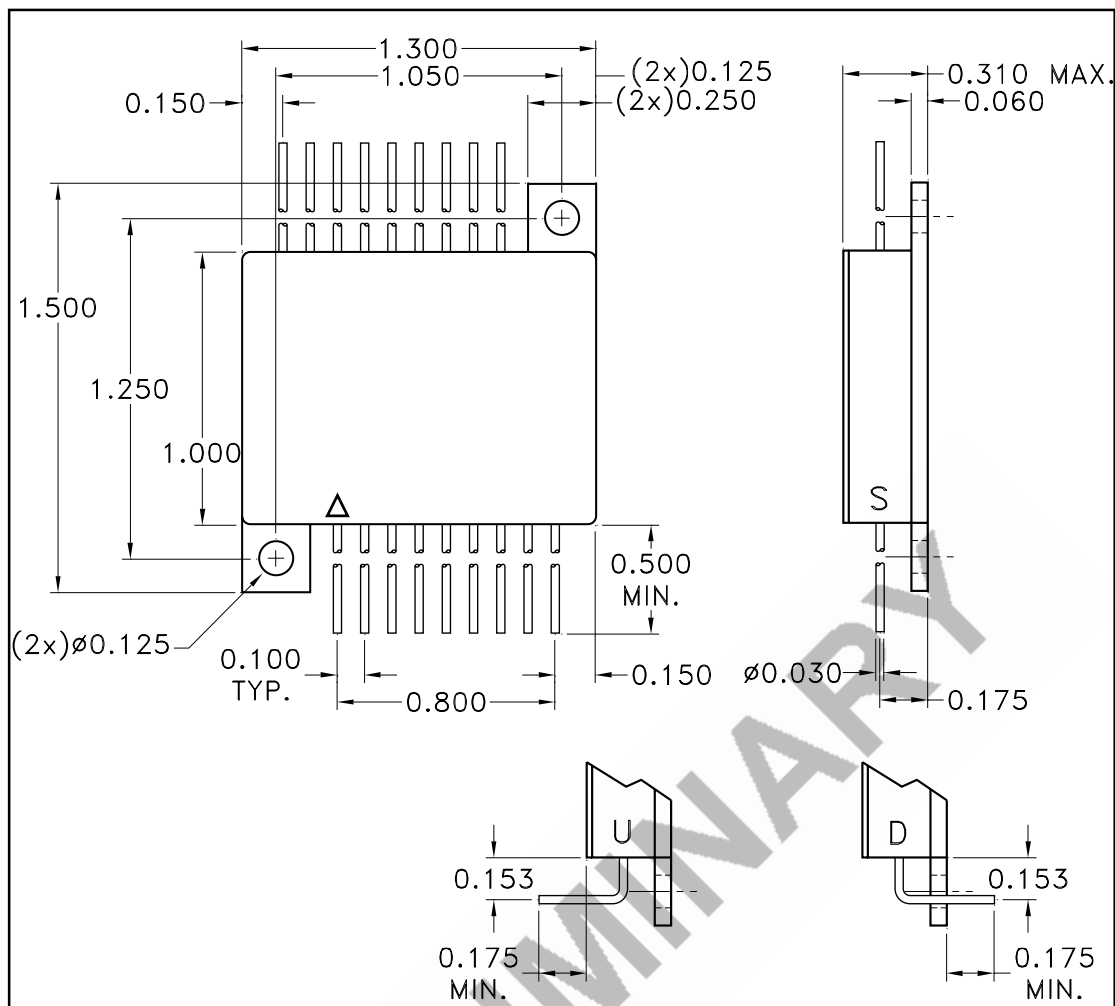

ALL DIMENSIONS ARE  $\pm 0.01$  INCHES UNLESS OTHERWISE LABELED

## ORDERING INFORMATION

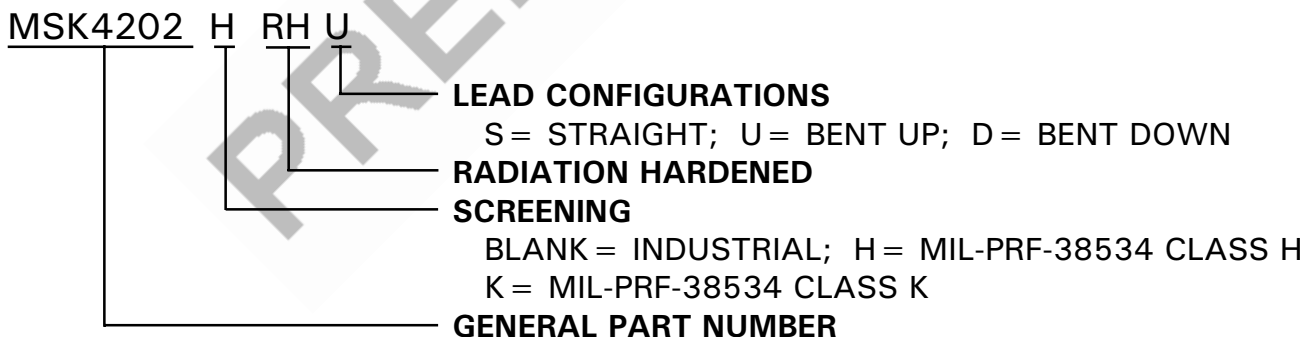

The above example is a Military grade class H hybrid with leads bent up.

M.S. Kennedy Corp.  
8170 Thompson Rd., Cicero, New York 13039-9393  
Tel. (315) 699-9201  
FAX (315) 699-8023